

## 30 to 60 V PTC Thermistors For Overload Protection

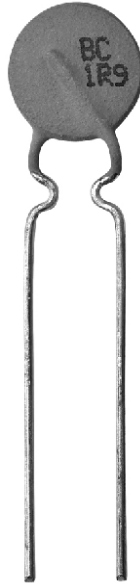

### FEATURES

- Wide range of trip and non-trip currents: from 94 mA up to 2 A for the trip current
- Wide range of resistance: from 0.3  $\Omega$  up to 50  $\Omega$
- Small ratio between trip and non-trip currents ( $I_t/I_{nt} = 1.5$  at 25 °C)
- High maximum inrush current (up to 23 A)
- Leaded parts withstand mechanical stresses and vibration
- UL file E148885 according to XGPU standard UL1434
- UL approved PTCs are guaranteed to withstand severe test programs
  - Long-life cycle tests (over 5000 trip cycles)
  - Long-life storage tests (3000 hours at 250 °C)
  - Electrical cycle tests at low ambient temperatures (- 40 °C or 0 °C)
  - Damp-heat and water immersion tests
  - Overvoltage tests at up to 200 % of rated voltage
- Component in accordance to RoHS 2002/95/EC and WEEE 2002/96/EC

### APPLICATIONS

- Telecommunications
- Automotive systems
- Industrial electronics
- Consumer electronics
- Electronic data processing

### DESCRIPTION

These directly heated thermistors have a positive temperature coefficient and are primarily intended for overload protection. They consist of a naked disk with two tinned brass or copper clad steel leads and coated. Leadless disks and leaded disks without coating are available on request.

### MOUNTING

The PTC Thermistors are suitable for processing on automatic insertion equipment.

#### Typical soldering

235 °C, duration: 5 s (Pb-bearing)  
245 °C, duration: 5 s (Lead (Pb)-free)

#### Resistance to soldering heat

260 °C, duration: 10 s max

### MARKING

Only the grey lacquered thermistors with a diameter of 8.5 to 20.5 mm are marked with BC, R25 value (example 1R9) on one side and  $I_{nt}$ ,  $V_{max}$  on the other side.

### QUICK REFERENCE DATA

PARAMETER	VALUE	UNIT
Switch temperature	140	°C
Maximum voltage (DC)	30 to 60	V
Temperature range	- 40 to + 85	°C
Climatic category	40/125/56	



ELECTRICAL DATA AND ORDERING INFORMATION for 2381 66. 5...1; max. voltage = 30 V to 60 V (ac or dc) <sup>1)</sup>									
I <sub>NT</sub> MAX. at 25 °C (mA)	I <sub>T</sub> MIN. at 25 °C (mA)	R <sub>25</sub> ± 20 % (Ω)	V MAX. (V)	I <sup>2</sup> MAX. at 25 °C (mA)	I <sub>RES</sub> MAX. at V <sub>MAX</sub> and 25 °C (mA)	DISSIP. FACTOR (mW/K)	Ø D MAX. (mm)	CATALOG NUMBERS	
								BULK	TAPE ON REEL
94	145	50	60	800	22	6.9	5	2381 660 59491	2381 660 69491
130	195	25	60	1200	25	6.9	5	2381 660 51311	2381 660 61311
180	270	13	30	1700	45	6.9	5	2381 660 51811	2381 660 61811
270	405	6	30	2500	60	6.9	5	2381 660 52711	2381 660 62711
320	480	5	30	3500	62	7.8	7	2381 661 53211	2381 661 63211
410	615	3	30	4500	65	7.8	7	2381 661 54111	2381 661 64111
470	705	2.5	30	5000	70	8.8	8.5	2381 661 54711	2322 661 64711
540	810	1.9	30	6000	75	8.8	8.5	2381 661 55411	2381 661 65411
610	915	1.7	30	7000	80	9.9	10.5	2381 662 56111	2381 662 66111
700	1050	1.3	30	8000	90	9.9	10.5	2381 662 57011	2381 662 67011
830	1245	1.1	30	10 000	100	11.5	12.5	2381 662 58311	2381 662 68311
920	1380	0.9	30	11 000	105	11.5	12.5	2381 662 59211	2381 662 69211
1170	1755	0.7	30	13 500	140	14.5	16.5	2381 663 51121	-
1390	2085	0.5	30	16 000	170	14.5	16.5	2381 663 51321	-
1770	2655	0.4	30	20 000	200	18.7	20.5	2381 664 51721	-
2050	3075	0.3	30	23 000	220	18.7	20.5	2381 664 52021	-

Notes

- The thermistors are clamped at the seating plane.
- I<sub>max</sub> is the maximum overload current that may flow through the PTC when it passes from the low ohmic to the high ohmic state.  
UL approval: I<sub>max</sub> \* 0.85

SAP AND 12NC PART NUMBERS			
12NC	SAP CODING	12NC	SAP CODING
2381 660 x9491	PTCCL05H940EyE	2381 662 x6111	PTCCL11H611DyE
2381 660 x1311	PTCCL05H131EyE	2381 662 x7011	PTCCL11H701DyE
2381 660 x1811	PTCCL05H181DyE	2381 662 x8311	PTCCL13H831DyE
2381 660 x2711	PTCCL05H271DyE	2381 662 x9211	PTCCL13H921DyE
2381 661 x3211	PTCCL07H321DyE	2381 663 51121	PTCCL17H112DBE
2381 661 x4111	PTCCL07H411DyE	2381 663 51321	PTCCL17H132DBE
2381 661 x4711	PTCCL09H471DyE	2381 664 51721	PTCCL21H172DBE
2381 661 x5411	PTCCL09H541DyE	2381 664 52021	PTCCL21H202DBE

Notes

- For bulk parts replace x by "5" and y by "B".
- For taped on reel parts replace it x by "6" and y by "T".

**CURRENT DEVIATION AS A FUNCTION OF THE AMBIENT TEMPERATURE**

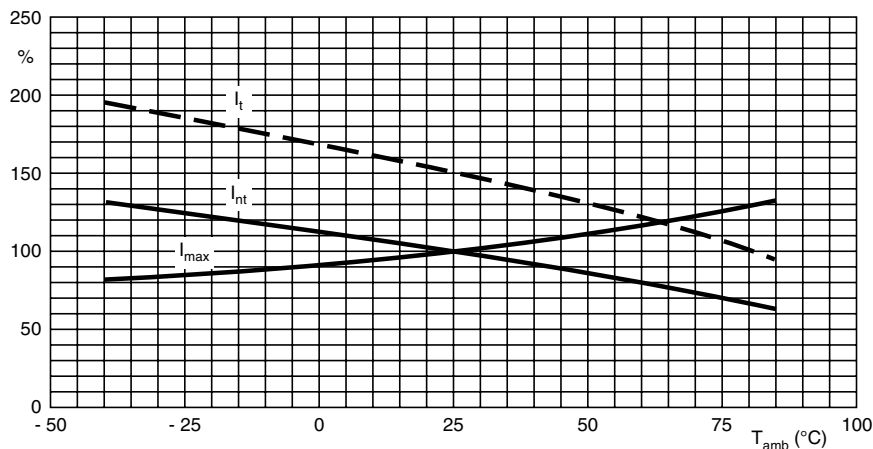

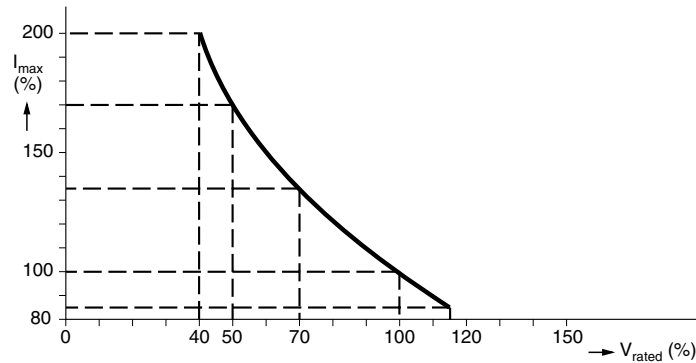
**ELECTRICAL CHARACTERISTICS**  
 **$I_{MAX}$  AS A FUNCTION OF VOLTAGE**

$I_{max}$  as stated in the Electrical data and ordering information tables, is the maximum overload current that may flow through the PTC when passing from the low ohmic to high ohmic state at rated voltage.

When other voltages are present after tripping, the  $I_{max}$  value can be derived from the above  $I_{max}$  as a function of voltage graph. Voltages below  $V_{rated}$  will allow higher overload currents to pass the PTC.

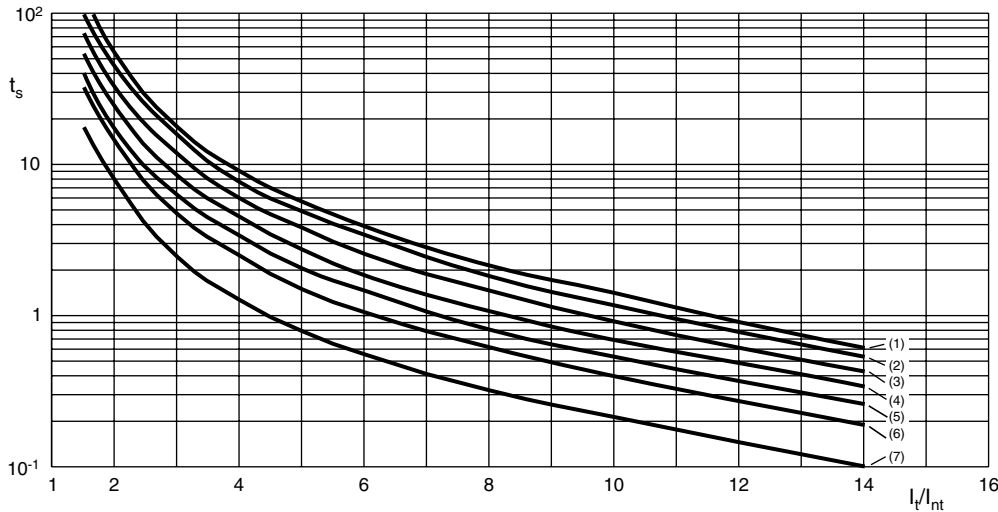
**TYPICAL TRIP-TIME AS A FUNCTION OF TRIP CURRENT RATIO**

Curve 1:  $\varnothing D_{max} = 20.5$  mm  
 Curve 2:  $\varnothing D_{max} = 16.5$  mm  
 Curve 3:  $\varnothing D_{max} = 12.5$  mm  
 Curve 4:  $\varnothing D_{max} = 10.5$  mm  
 Curve 5:  $\varnothing D_{max} = 8.5$  mm  
 Curve 6:  $\varnothing D_{max} = 7.0$  mm  
 Curve 7:  $\varnothing D_{max} = 5.0$  mm  
 Measured in accordance with  
 "IEC 60738".

**Trip-time or switching time ( $t_s$ )**

To check the trip-time for a specific PTC, refer to the Electrical Data and Ordering Information tables for the value  $I_{nt}$ . Divide the overload or trip current by this  $I_{nt}$  and you realize the factor  $I_t/I_{nt}$ . This rule is valid for any ambient temperature between 0 and 70 °C. Adapt the correct non-trip current with the appropriate curve in the Current Deviation as a Function of the Ambient Temperature graph. The relationship between the  $I_t/I_{nt}$  factor and the switching time is a function of the PTC diameter; see the above graphs.

**Example**

What will be the trip-time at  $I_{ol} = 3$  A and  $T_{amb} = 0$  °C of a thermistor type 2381 661 54711; 2.5  $\Omega$ ;  $\varnothing D_{max} = 8.5$  mm:

$I_{nt}$  from the table: 470 mA at 25 °C

$I_{nt}$ : 470 x 1.12 = 526 mA (at 0 °C).

Overload current = 3 A; factor  $I_t/I_{nt}$ :  $3/0.526 = 5.70$ . In the typical trip-time as a function of trip current ratio graph, at the 8.5 mm line and  $I_t/I_{nt} = 5.70$ , the typical trip-time is 1.7 s.

COMPONENTS OUTLINE			
CODE NUMBER 2381		S.P.Q	OUTLINE
660	5...1	500	Fig. 1a
	6...1	1500	Fig. 1b
661	5...1	250	Fig. 1a
	6...1	1500	Fig. 1b
662	5...1	250	Fig. 1a
	66111 - 67011	1500	Fig. 1b
	68311 - 69211	750	Fig. 1c
663	5...1	200	Fig. 1a
664	5...1	100	Fig. 1a

**PTC THERMISTORS IN BULK**

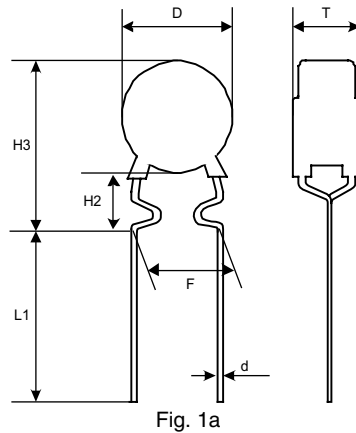

**PTC THERMISTORS ON TAPE ON REEL**

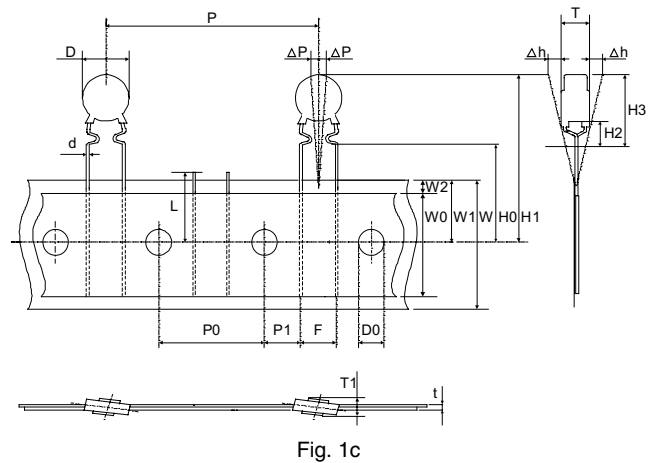
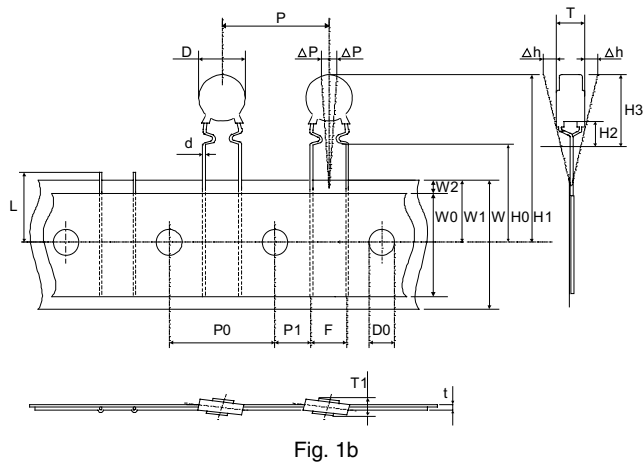

TAPE AND REEL ACCORDING TO IEC 60286-2 dimensions in millimeters				
SYMBOL	PARAMETER	DIMENSIONS	TOLERANCE	REMARKS
D	Body diameter	See table	max.	
d	Lead diameter	0.6	± 10 %	
D0	Feed hole diameter	4.0	± 0.2	
P	Pitch of components			
	Diameter < 12 mm	12.7	± 1.0	
	Diameter ≥ 12 mm	25.4	± 2.0	
P0	Feed hole pitch	12.7	± 0.3	Cumulative pitch error ± 1 mm/20 pitches guaranteed between component and tape
P1	Feed hole center to lead center	3.81	± 0.7	
Δp	Component alignment	0	± 1.3	
F	Lead center to lead center distance	5.0	+ 0.6 - 0.1	Guaranteed between component and tape
H0	Lead wire clinch height	16.0	± 0.5	
H2	Component bottom to seating plane	4.0	± 1.0	
H3	Component top to seating plane	D + 5	max.	
H4	Seating plane difference (left-right lead)	0	± 0.2	
Δh	Component alignment	0	± 2.0	
L1	Lead length	20	min.	
W	Tape width	18	+ 1/- 0.5	
W0	Hold down tape width	9.0	min.	
W1	Hole Position	9.0	± 0.5	
W2	Hold down tape position	3.0	max.	
T	Total thickness	4.0	max.	With cardboard tape 0.5 ± 0.1 mm
t	Total tape thickness	0.9	max.	

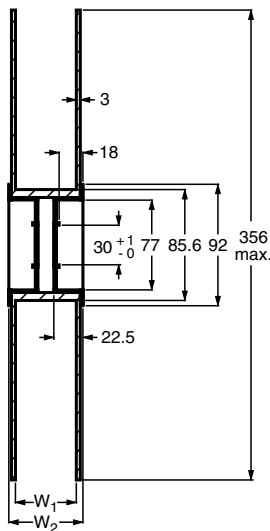
**REEL SPECIFICATIONS** in millimeters

REEL DIMENSIONS in millimeters		
DIAMETER Ø	W <sub>1</sub>	W <sub>2</sub> MAX.
< 12	42 ± 1	56
12	46 ± 1	60



## TYPICAL RESISTANCE/TEMPERATURE CHARACTERISTIC

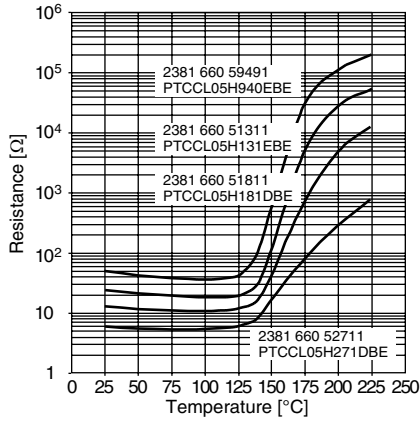

## TYPICAL RESISTANCE/TEMPERATURE CHARACTERISTIC

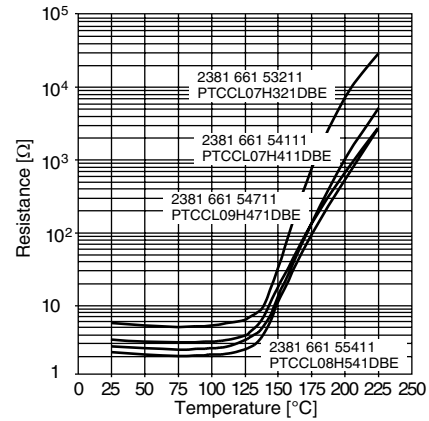

## TYPICAL RESISTANCE/TEMPERATURE CHARACTERISTIC

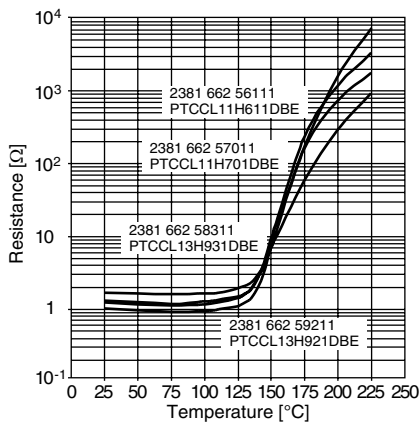

## TYPICAL RESISTANCE/TEMPERATURE CHARACTERISTIC

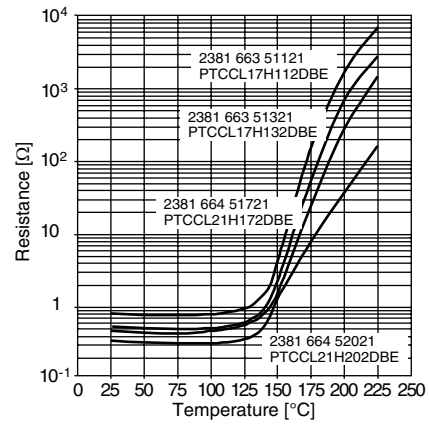



## Notice

Specifications of the products displayed herein are subject to change without notice. Vishay Intertechnology, Inc., or anyone on its behalf, assumes no responsibility or liability for any errors or inaccuracies.

Information contained herein is intended to provide a product description only. No license, express or implied, by estoppel or otherwise, to any intellectual property rights is granted by this document. Except as provided in Vishay's terms and conditions of sale for such products, Vishay assumes no liability whatsoever, and disclaims any express or implied warranty, relating to sale and/or use of Vishay products including liability or warranties relating to fitness for a particular purpose, merchantability, or infringement of any patent, copyright, or other intellectual property right.

The products shown herein are not designed for use in medical, life-saving, or life-sustaining applications. Customers using or selling these products for use in such applications do so at their own risk and agree to fully indemnify Vishay for any damages resulting from such improper use or sale.