

Power Line Filters Appliance Filters

62-AL/62-AC Series



Tested and found to be
IAW VDE 0565 Part 3

Features

- Low-cost plastic case
- Compact design requires minimal real estate space
- Suitable for products that must conform to FCC regulations
- Wide variety of circuit and filtering options
- Good filtering characteristics for both normal mode and common mode
- Epoxy molded for reliability
- Operating temperature: -25°C to +85°C (including temperature rise, see graph on page 61)

Applications

- Personal computers and peripherals
- Digital equipment
- Industrial equipment
- Vending machines
- Home appliances
- Office equipment

Specifications

Model*	Rated Voltage (@ 50/60Hz)	Rated Current	Leakage Current (Max.)	Capacitance		Inductance (L ₁)	Temperature Rise (Max.)			
				C _Y	C _X					
62-AFL-010-3-11	250VAC	1.0A	0.35mA	2200pF	0.1uF	11.0mH	40°C			
62-AFC-010-3-11			0.50mA	3300pF						
62-AFL-010-5-11				1.6A				0.35mA	2200pF	
62-AFC-010-5-11			0.50mA					3300pF		
62-AFL-016-3-11		3.0A	0.35mA	2200pF		2.4mH				
62-AFC-016-3-11				0.50mA				3300pF		
62-AFL-016-5-11								4.5A	0.35mA	2200pF
62-AFC-016-5-11				0.50mA					3300pF	
62-AFL-030-3-11		6.0A	0.35mA	2200pF		0.53mH				
62-AFC-030-3-11				0.50mA				3300pF		
62-AFL-030-5-11								6.0A	0.35mA	2200pF
62-AFC-030-5-11				0.50mA					3300pF	
62-AFL-045-3-11		6.0A	0.35mA	2200pF		0.53mH				
62-AFC-045-3-11				0.50mA				3300pF		
62-AFL-045-5-11								6.0A	0.35mA	2200pF
62-AFC-045-5-11				0.50mA					3300pF	
62-AFL-060-3-11		6.0A	0.35mA	2200pF		0.53mH				
62-AFC-060-3-11				0.50mA				3300pF		
62-AFL-060-5-11								6.0A	0.35mA	2200pF
62-AFC-060-5-11				0.50mA					3300pF	

Note: All types are designed to meet the requirement of UL 1283, CSA 22.2. VDE 0565-3
 Test voltage: 1500VAC one minute, line to ground
 Insulation resistance: 300 Mohm min. at 500VDC
 Voltage drop: 1V max.

* Available with bleeder resistor
 Replace F with R for part number

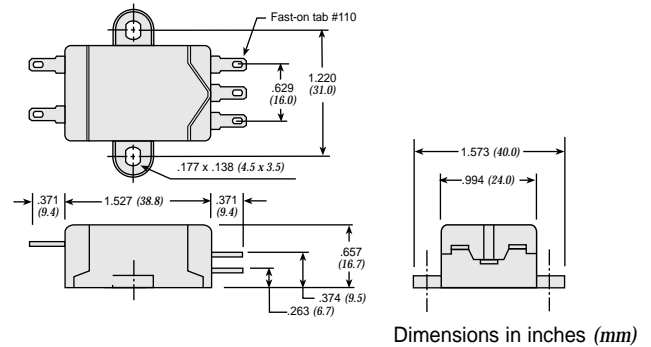

Circuit Diagrams

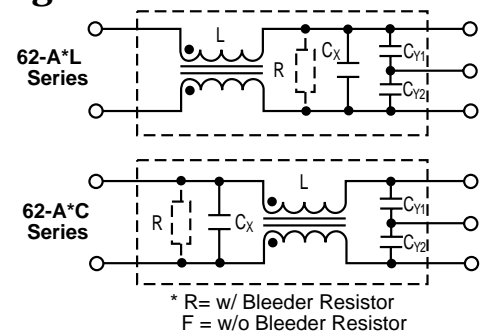

Power Line Filters Appliance Filters

62-AL/62-AC Series

Common Mode

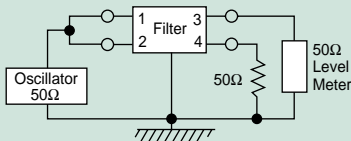

62-AFL-xxx-3-11

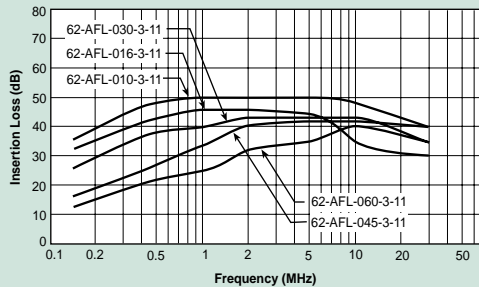

62-AFC-XXX-3-11

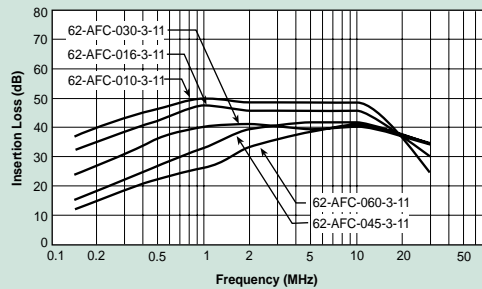

62-AFL-xxx-5-11

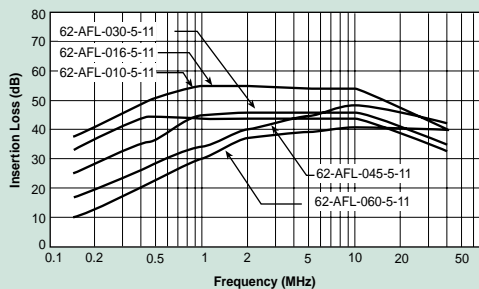

62-AFC-xxx-5-11

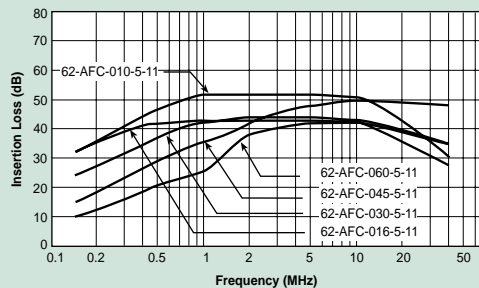

Temperature Characteristics

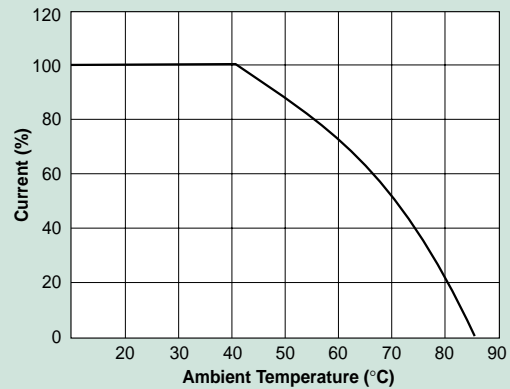

Normal Mode

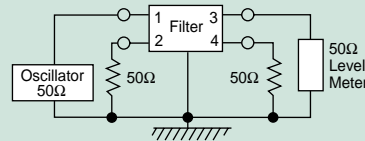

62-AFL-XXX-3-11

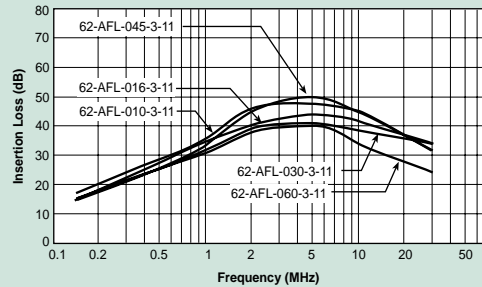

62-AFC-XXX-3-11

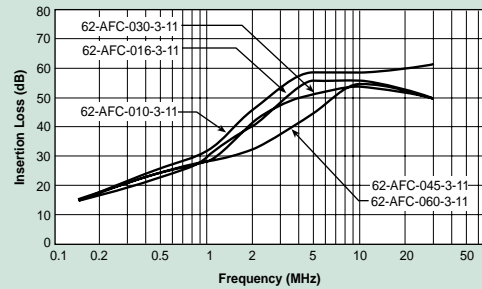

62-AFL-xxx-5-11

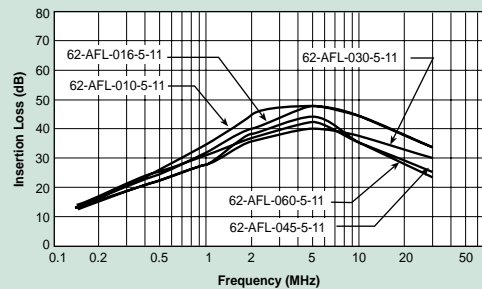

62-AFC-xxx-5-11

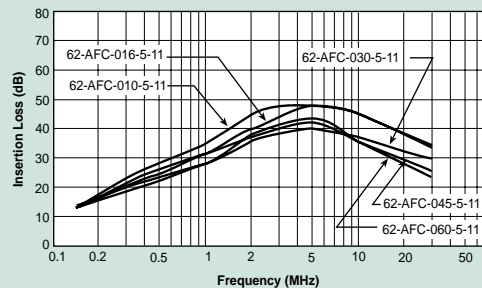

Power Line Filters Single Stage

62-PPF/PQF/PRF Series



Tested and found to be
IAW VDE 0565 Part 3

Features

- Low-cost plastic case
- Compact design requires minimal real estate space
- Suitable for products that must conform to FCC and FTZ regulations
- Wide variety of circuit and filtering options
- Good filtering characteristics for both normal mode and common mode
- Epoxy molded for reliability
- Operating temperature: -25°C to +85°C (including temperature rise, see graph on page 63)

Applications

- Personal computers and peripherals
- Digital equipment
- Industrial equipment
- Vending machines
- Office equipment



Circuit Diagrams

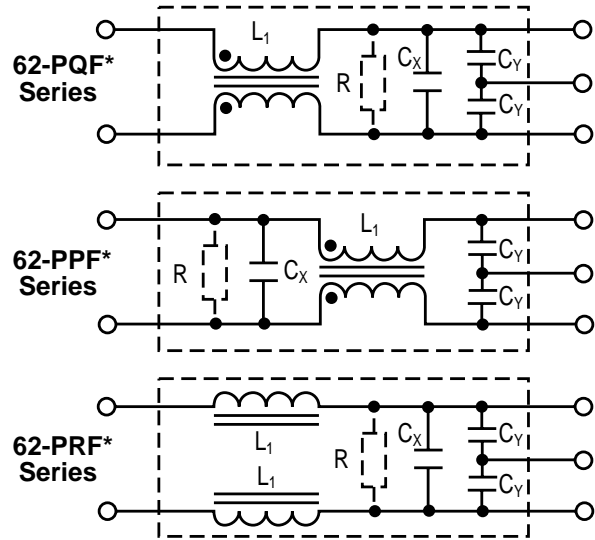

* Bleeder Resistor is available only for
62-P(Q/R/P)F-XXX-X-12

Specifications

Model	Rated Voltage (@ 50/60Hz)	Rated Current	Leakage Current (Max.)	Capacitance		Inductance (L ₁)	Temperature Rise (Max.)				
				C _Y	C _X						
62-PQF-020-5-11	250VAC	2A	0.50mA	3300pF	0.1uF	15mH	30°C				
62-PQF-020-5-12					.22uF						
62-PPF-020-5-11					0.1uF			8mH			
62-PPF-020-5-12					.22uF						
62-PQF-030-5-11					0.1uF				2.1mH		
62-PQF-030-5-12					.22uF						
62-PPF-030-5-11		0.1uF			486uH						
62-PPF-030-5-12		.22uF									
62-PQF-060-5-11		0.1uF				181uH					
62-PQF-060-5-12		.22uF									
62-PPF-060-5-11		0.1uF						97uH			
62-PPF-060-5-12		.22uF									
62-PRF-010-5-11		1A			3A				.22uF		
62-PRF-010-5-12		2A									
62-PRF-020-5-11		2A			3A	.22uF					
62-PRF-020-5-12		3A									
62-PRF-030-5-11											
62-PRF-030-5-12											

Note: All types are designed to meet the requirement of UL 1283, CSA 22.2, VDE 0565-3

Test voltage: 1500VAC one minute, line to ground

Insulation resistance: 300 Mohm min. at 500VDC

Voltage drop: 1V max. (except 62-PRF-010-5-11) at rated current

62-PRF-010-5-11: 1.5V max. at rated current

Weight: 62-PPF & PQF Series: 2.11 ounces (60 grams)

62-PRF Series: 1.76 ounces (50 grams)

Power Line Filters Single Stage

62-PPF/PQF/PRF Series

Temperature Characteristics

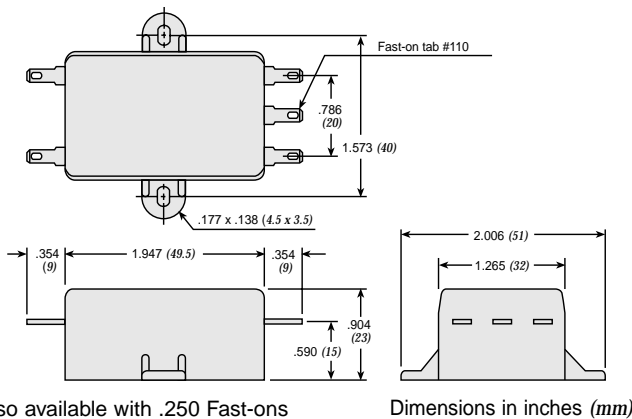
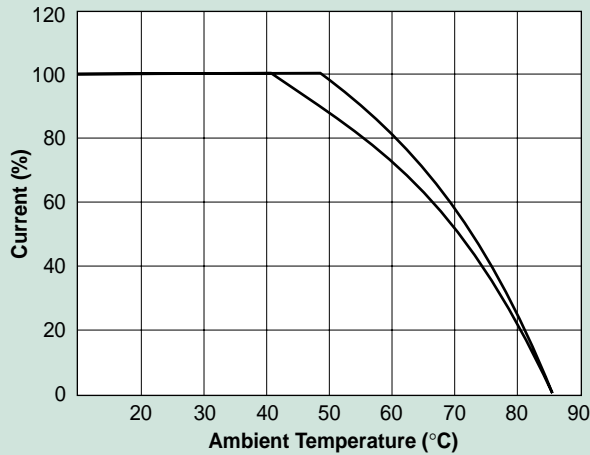

Normal Mode

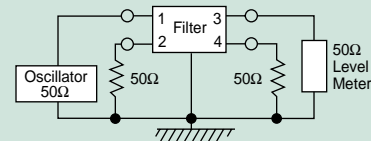

62-PQF Series

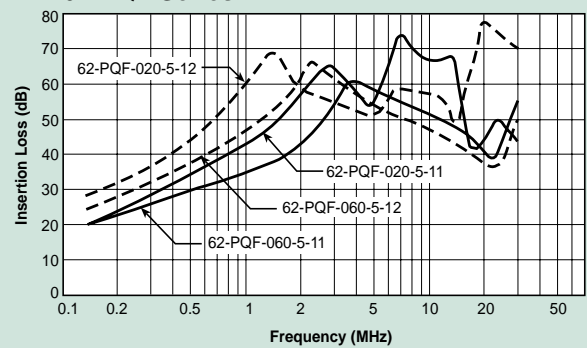

62-PPF Series

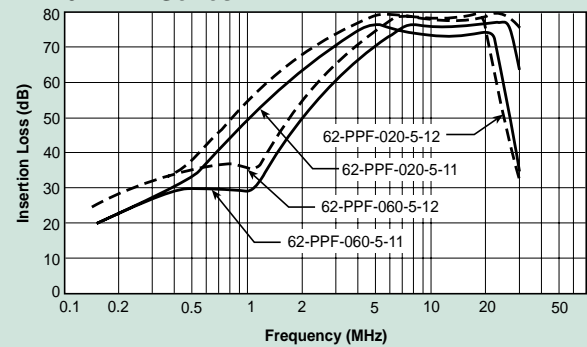

Common Mode

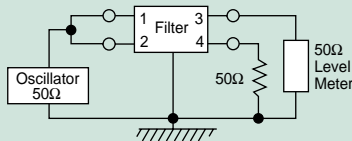

62-P(Q/R)F Series

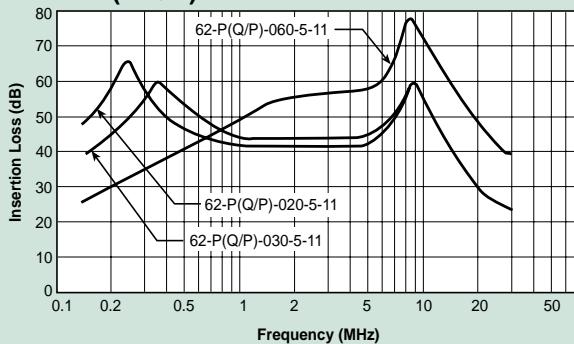

62-PRF Series

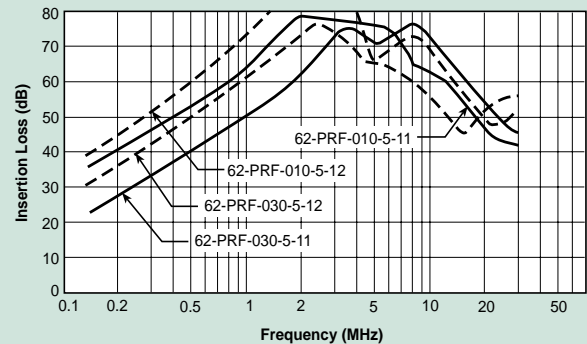

Power Line Filters Single Stage Wire Leads

62-PML Series



Tested and found to be
IAW VDE 0565 Part 3

Features

- Compact design requires minimal real estate space
- Suitable for products that must conform to FCC and FTZ regulations
- Excellent attenuation for high voltage impulse
- Metal case provides effective shielding
- Excellent filtering characteristics for both normal mode and common mode
- Structure provides effective shielding for noise generated externally and internally
- Operating temperature: -25°C to +85°C (including temperature rise, see graph on page 65)

Applications

- Digital equipment
- Personal computers and peripherals
- Measuring instruments
- Medical equipment
- Factory automation equipment



Circuit Diagram

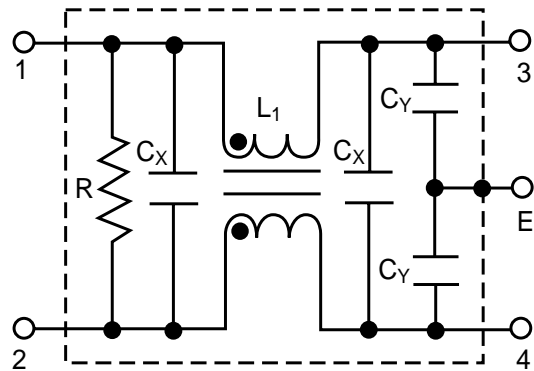

Specifications

Model	Rated Voltage (@ 50/60Hz)	Rated Current	Leakage Current (Max.)	Capacitance		Inductance (L ₁)	Temperature Rise (Max.)
				C _Y	C _X		
62-PML-015-3-11	250VAC	1.5A	0.35mA	2200pF	0.1uF	10.0mH	30°C
62-PML-015-5-11			0.50mA	3300pF			
62-PML-030-3-11		3A	0.35mA	2200pF		4.3mH	
62-PML-030-5-11			0.50mA	3300pF			
62-PML-050-3-11		5A	0.35mA	2200pF		2.4mH	
62-PML-050-5-11			0.50mA	3300pF			
62-PML-100-5-11		10A	0.50mA	3300pF		2.2mH	

Note: All types are designed to meet the requirement of UL 1283, CSA 22.2, VDE 0565-3
 Test voltage: 1500VAC one minute, line to ground
 Insulation resistance: 300 Mohm min. at 500VDC
 Voltage drop: 1V max. at rated current
 Weight: 62-PML-015 Series: 3.06 ounces (87 grams)
 62-PML-030 Series: 3.17 ounces (90 grams)
 62-PML-050 Series: 3.28 ounces (93 grams)
 Discharge time: 0.4 sec. max.

Power Line Filters Single Stage Wire Leads

62-PML Series

Temperature Characteristics

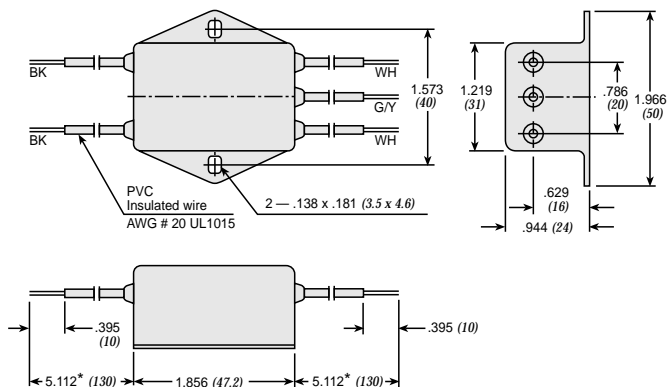
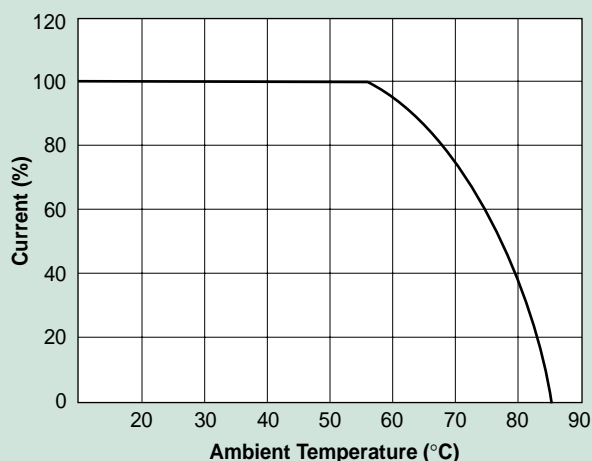

* Custom lengths available upon request. Dimensions in inches (mm)

Common Mode

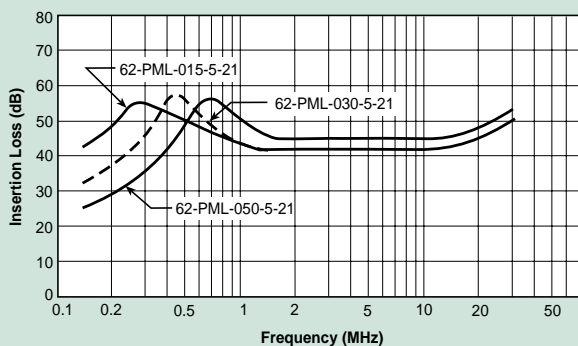
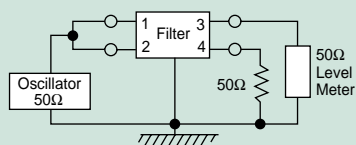

Normal Mode

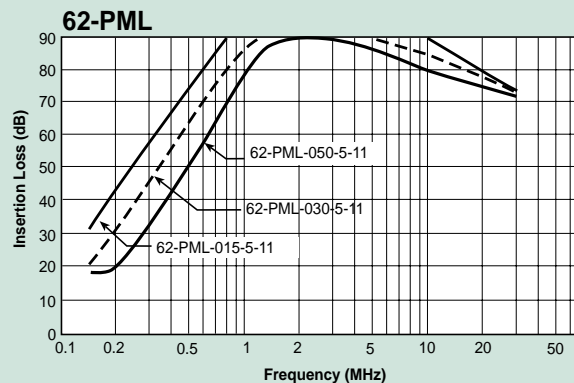
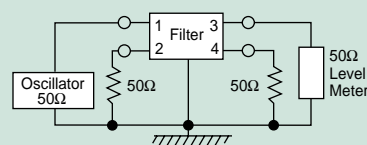

Power Line Filters

Single Stage Wire Leads

for Medical Purpose Applications

12-PML & 12-PMF Series



Features

- Compact design requires minimal real estate space
- Suitable for products that must conform to FCC and FTZ regulations
- Excellent attenuation for high voltage impulse
- Metal case provides effective shielding
- Excellent filtering characteristics for both normal mode and common mode
- Structure provides effective shielding for noise generated externally and internally
- Operating temperature: -25°C to +70°C
- Low leakage current

Applications

- Digital equipment
- Personal computers and peripherals
- Measuring instruments
- Medical equipment
- Factory automation equipment



Circuit Diagram

Circuit 1

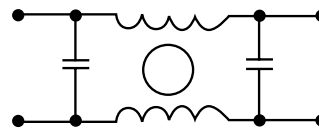

Circuit 2

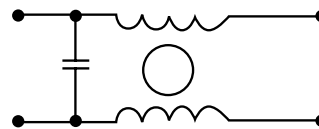

Specifications

Model	Rated Voltage (@ 50/60Hz)	Rated Current	Leakage Current (Max.)	Circuit Diagram	Figure	Temperature Rise (Max.)
12-PML-001-2-A	120/250VAC	1A	5uA	1	A	30°C
12-PML-002-2-A		2A				
12-PML-006-2-A		6A				
12-PML-010-2-A		10A				
12-PMF-001-2-B		1A		2	B	
12-PMF-002-2-B		2A				
12-PMF-006-2-B		6A				
12-PML-001-2-C				1A		

Note: All types are designed to meet the requirement of UL 1283, CSA 22.2. VDE 0565-3
 Test voltage: 1500VAC one minute, line to ground
 Insulation resistance: 300 Mohm min. at 500VDC
 Voltage drop: 1V max. at rated current
 Discharge time: 0.4 sec. max.

Power Line Filters

Single Stage Wire Leads

for Medical Purpose Applications

12-PML & 12-PMF Series

Figure A

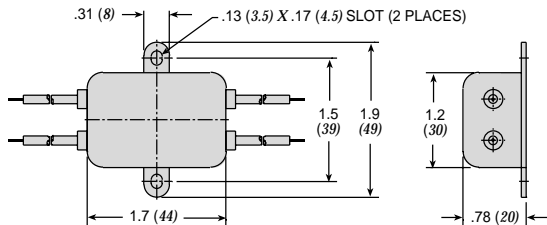

Figure C

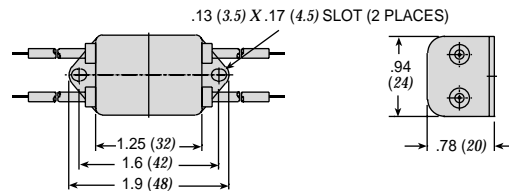
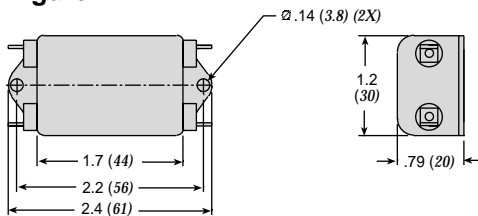
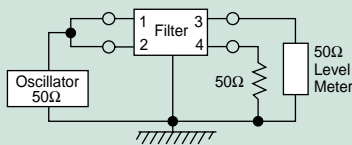

Figure B



Dimensions in inches (mm)

Common Mode



12-PML-001;-002;-006;-010

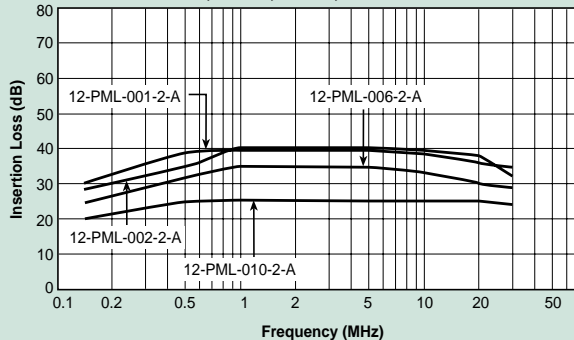

12-PMF-001;-002;-006;-010

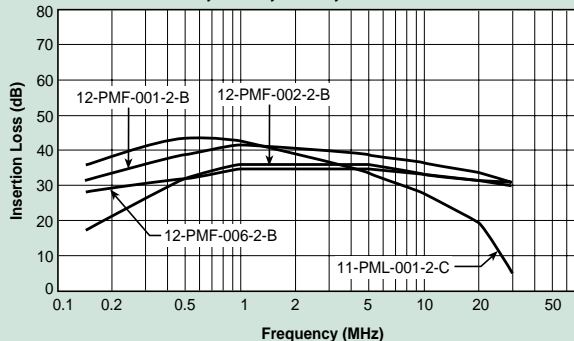

Normal Mode

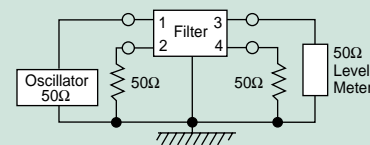

12-PML-001;-002;-006;-010

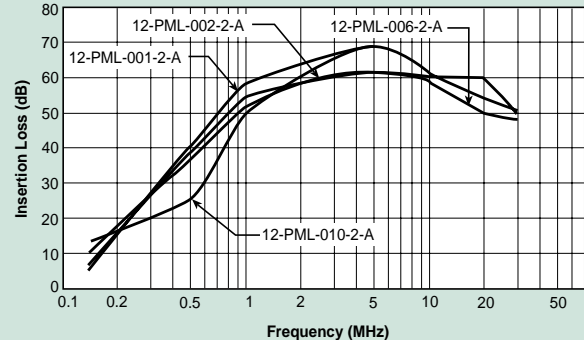

12-PMF-001;-002;-006;-010

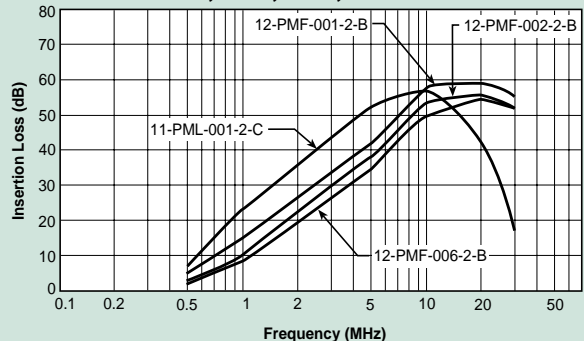

Power Line Filters Single Stage

62-LMF & LMB Series



Tested and found to be
IAW VDE 0565 Part 3

Features

- Space saving, compact designs
- Suitable for products that must conform to FCC and FTZ regulations
- Excellent filtering characteristics for both normal mode and common mode
- Structure provides effective shielding for noise generated externally and internally
- Metal case provides effective shielding
- Rugged construction
- Operating temperature: -25°C to +85°C (including temperature rise, see graph on page 69)

Applications

- Digital equipment
- Office automation equipment, such as copy and fax machines
- Computers and peripherals
- Instrumentation and controls



Circuit Diagram

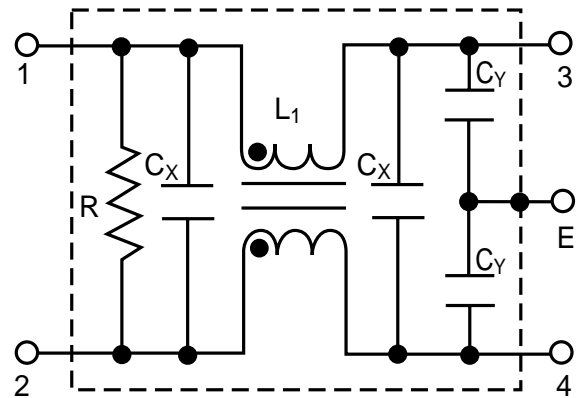

Specifications

Model*	Rated Voltage (@ 50/60Hz)	Rated Current	Leakage Current (Max.)	Capacitance		Inductance (L ₁)	Temperature Rise (Max.)	
				C _Y	C _X			
62-LMB-030-5-11	250VAC	3A	0.50mA	3300pF	0.1uF	14mH	45°C	
62-LMF-030-5-11		5A			0.1uF & .22uF	7.0mH		
62-LMB-050-5-11					8A	.22uF		4.2mH
62-LMF-050-5-11		10A				.33uF		2.2mH
62-LMB-080-5-11					.33uF	2.2mH		2.2mH
62-LMF-080-5-11								
62-LMB-100-5-11					.33uF	2.2mH		2.2mH
62-LMF-100-5-11		.33uF						

Note: Test voltage: 1500VAC one minute, line to ground
 Insulation resistance: 300 Mohm min. at 500VDC
 Voltage drop: 1V max. at rated current
 Discharge time: 0.4 sec. max.
 Weight: 5.3 ounces (150 grams)

*62-LMF - designates Fast-on terminals
 62-LMB - designates Bolt-in terminals
 62-LML - wire lead in/outputs also available

Power Line Filters Single Stage

62-LMF & LMB Series

Temperature Characteristics

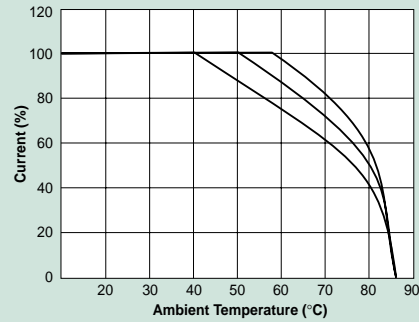

62-LMB

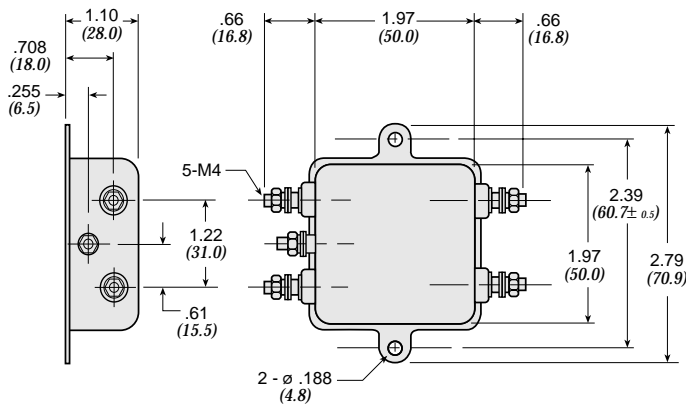

62-LMF

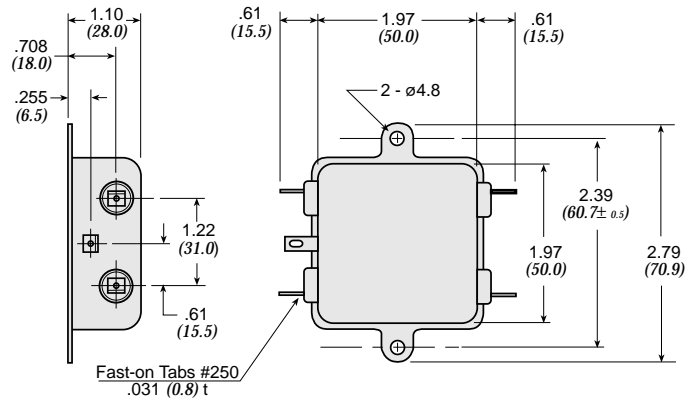

Dimensions in inches (mm)

Common Mode

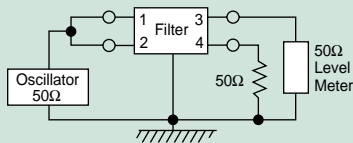

Normal Mode

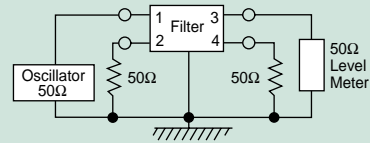

62-LMF & LMB

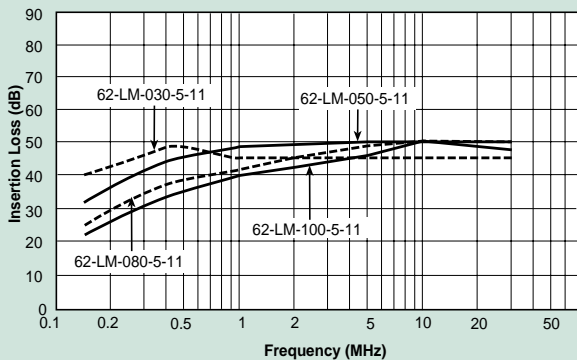

62-LMF & LMB

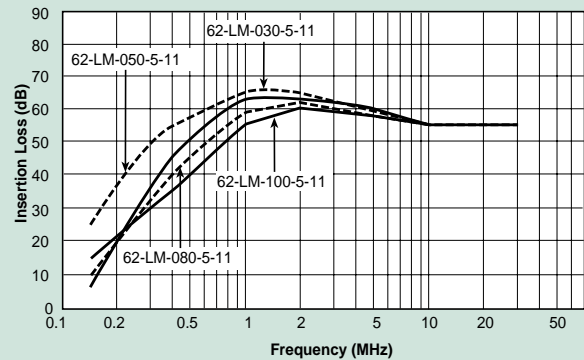

Power Line Filters Single Stage

62-PMF & PMB Series



Tested and found to be
IAW VDE 0565 Part 3

Features

- Space-saving, compact designs
- Suitable for products that must conform to FCC regulations
- Excellent attenuation for high voltage impulse
- Metal case provides effective EMI shielding
- Excellent filtering characteristics for both normal mode and common mode
- Epoxy molded for internal component reliability
- Structure provides effective shielding for noise generated externally and internally
- Operating temperature: -25°C to +85°C (including temperature rise, see graph on page 71)

Applications

- Digital equipment
- Computers and peripherals
- Measuring instruments
- Medical equipment
- Equipment requiring very high impulse attenuation
- Factory automation equipment
- Industrial equipment such as UPS, inverters and converters
- Telecommunications equipment
- Office automation equipment, such as copy and fax machines



Circuit Diagram

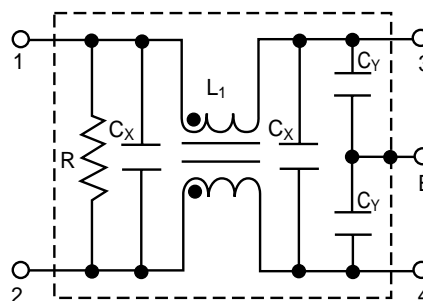

Specifications

Model*	Rated Voltage (@ 50/60Hz)	Rated Current	Leakage Current (Max.)	Capacitance		Inductance (L ₁)	Temperature Rise (Max.)	
				C _Y	C _X			
62-PMB-050-5-11	250VAC	5A	0.50mA	3300pF	0.1uF	14mH	30°C	
62-PMF-050-5-11								
62-PMB-080-5-11		8A			.1uF & .22uF	7.0mH		
62-PMF-080-5-11								
62-PMB-100-5-12		10A			.22uF	4.2mH		
62-PMF-100-5-12								
62-PMB-150-5-13		15A			.33uF	2.2mH		35°C
62-PMF-150-5-13								
62-PMB-200-5-13		20A			1.8mH	45°C**		
62-PMF-200-5-13								

Note: Test voltage: 1500VAC one minute, line to ground
Insulation resistance: 300 Mohm min. at 500VDC
Voltage drop: 1V max.
Discharge time: 0.4 sec. max.
Weight: 8.82 ounces (250 grams)

* PMF - designates Fast-on terminals
PMB - designates Bolt-in terminals

** The temperature rise of 20 amp units can be decreased to 30°C by mounting on 200 X 200 x 1.0(mm) steel chassis

Power Line Filters Single Stage

62-PMF & PMB Series

Temperature Characteristics

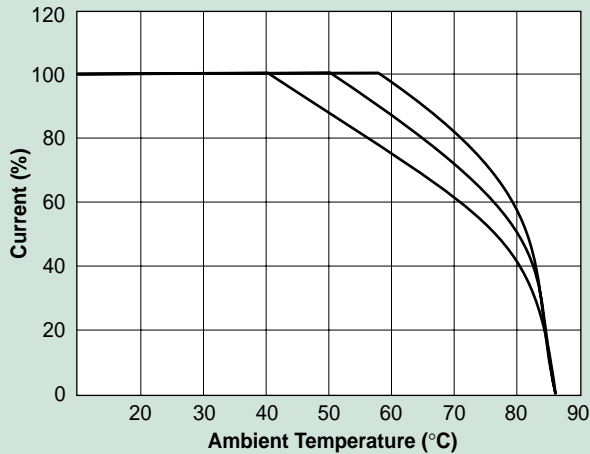

62-PMF

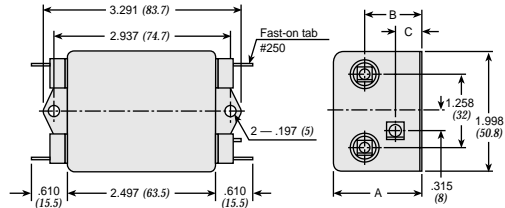

62-PMB

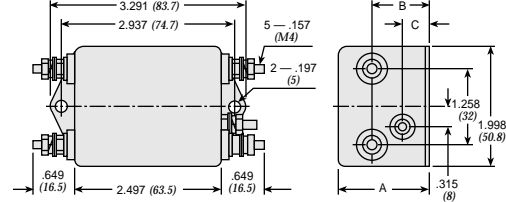

MODEL	A	B	C
62-PMF/PMB-100-200	1.490 (38)	.944 (24)	.433 (11)
62-PMF/PMB-050-080	1.258 (32)	.786 (20)	0 (0)

Dimensions in inches (mm)

Common Mode

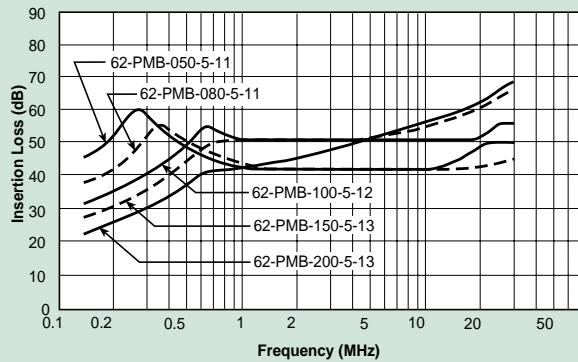
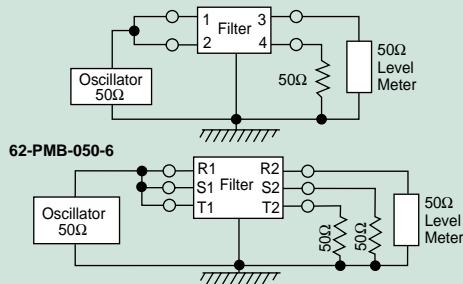

Normal Mode

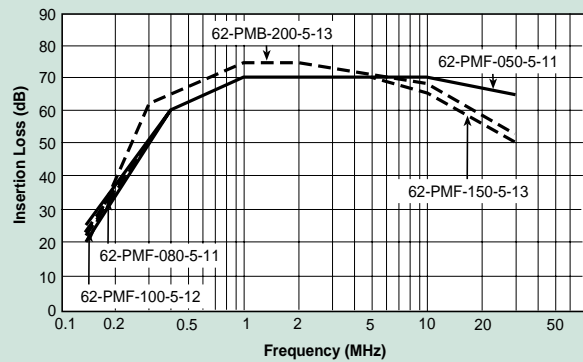
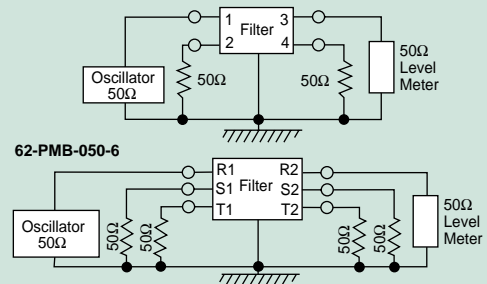

Power Line Filters Single Stage

12-PMF Series



Features

- Space-saving, compact designs
- Suitable for products that must conform to FCC regulations
- Excellent attenuation for high voltage impulse
- Metal case provides effective EMI shielding
- Excellent filtering characteristics for both normal mode and common mode
- Epoxy molded for internal component reliability
- Structure provides effective shielding for noise generated externally and internally
- Operating temperature: -40°C to +85°C

Applications

- Digital equipment
- Computers and peripherals
- Measuring instruments
- Medical equipment
- Equipment requiring very high impulse attenuation
- Factory automation equipment
- Industrial equipment such as UPS, inverters and converters
- Telecommunications equipment
- Office automation equipment, such as copy and fax machines



Circuit Diagram

Circuit 1

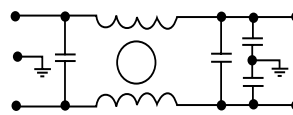

Circuit 2

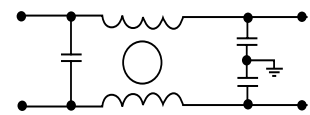

Circuit 3

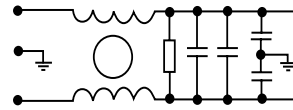

Circuit 4

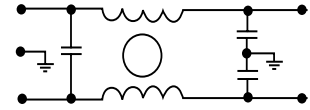

Circuit 5

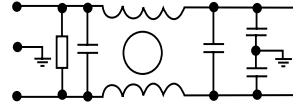

Circuit 6

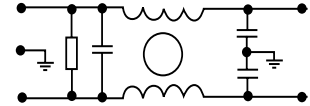

Specifications

Model	Rated Voltage (@ 50/60Hz)	Rated Current	Leakage Current (Max.)	Circuit Diagram	Figure	Temperature Rise (Max.)
12-PMF-001-5-A	120/250VAC	1A	0.5mA	1	A	30°C
12-PMF-002-5-B		2A		2	B	
12-PMF-003-5-A		3A		4	A	
12-PMF-003-5-B		2		B		
12-PMF-006-5-A		6A		4	A	
12-PMF-006-5-C		1		C		
12-PMF-006-5-D		6		D		
12-PMF-010-5-A		10A		2	A	
12-PMF-010-5-C		3		C		
12-PMF-015-5-C		15A		5	E	
12-PMF-015-5-E		C				
12-PMF-020-5-C		20A			D	
12-PMF-020-5-D		D				
12-PMF-020-5-E		E				

Note: Test voltage: 1500VAC one minute, line to ground
 Insulation resistance: 300 Mohm min. at 500VDC
 Voltage drop: 1V max.
 Discharge time: 0.4 sec. max.

Power Line Filters Single Stage

12-PMF Series

Figure A

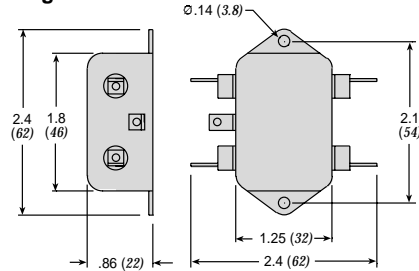

Figure B

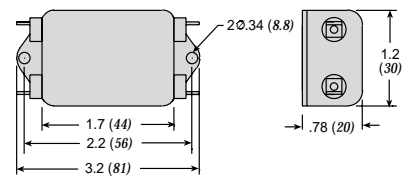

Figure C

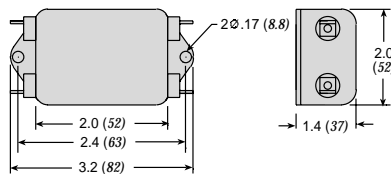

Figure D

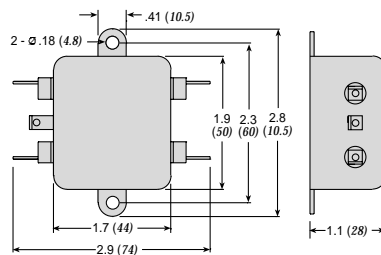
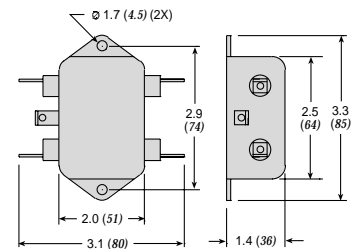
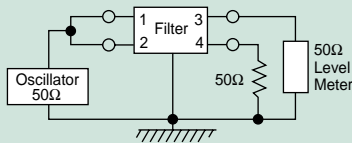

Figure E



Dimensions in inches (mm)

Common Mode



12-PMF-001;-002;-003;-006

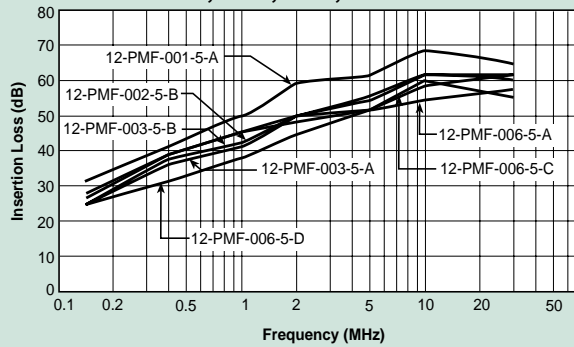

12-PMF-001;-002;-003;-006

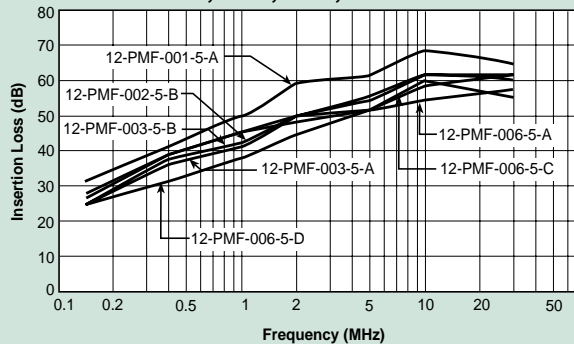

Normal Mode

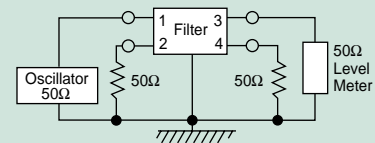

12-PMF-001;-002;-003;-006

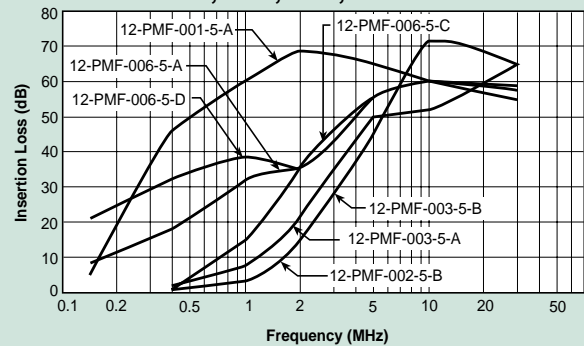

12-PMF-010;-015;-020

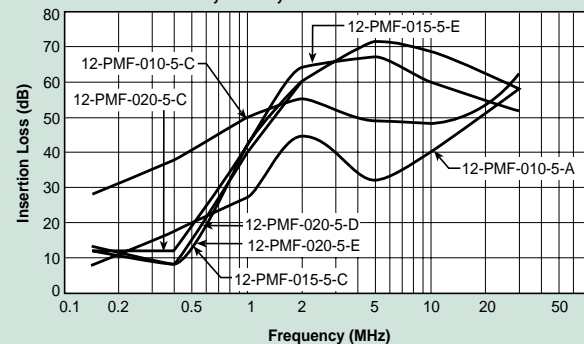

Power Line Filters Single Stage - Higher Current



62-PMB Series

Features

- Space-saving, compact designs
- Suitable for products that must conform to FCC regulations
- Excellent attenuation for high voltage impulse
- Metal case provides effective shielding
- Excellent filtering characteristics for both normal mode and common mode
- Epoxy molded for internal component reliability
- Structure provides effective shielding for noise generated externally and internally
- Safety agency approvals pending
- Designed to be in accordance with VDE 0565 Part 3
- Operating temperature: -25°C to +85°C (including temperature rise)

Applications

- Digital equipment
- Computers and peripherals
- Measuring instruments
- Medical equipment
- Equipment requiring very high impulse attenuation
- Factory automation equipment
- Industrial equipment such as UPS, inverters and converters
- Telecommunications equipment
- Office automation equipment, such as copy and fax machines

Circuit Diagram

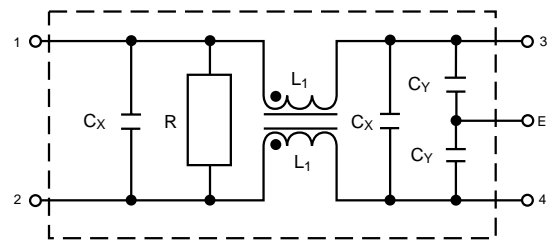

Specifications

Model	Rated Voltage (@ 50/60Hz)	Rated Current	Leakage Current (Max.)	Capacitance		Inductance (L ₁)	Temperature Rise (Max.)
				C _Y	C _X		
62-PMB-300-5-14	250VAC	30A	0.50mA	3300pF	.47uF	1.6mH	45°C
62-PMB-400-5-14		40A				0.8mH	

Note: Test voltage: 1500VAC one minute, line to earth
 Insulation resistance: 300 Mohm min. at 500VDC
 Voltage drop: 1V max.
 Discharge time: 0.4 sec. max.
 Weight: 8.82 ounces (250 grams)

Power Line Filters Single Stage - Higher Current

62-PMB Series

62-PMB-300-5-14 and 62-PMB-400-5-14

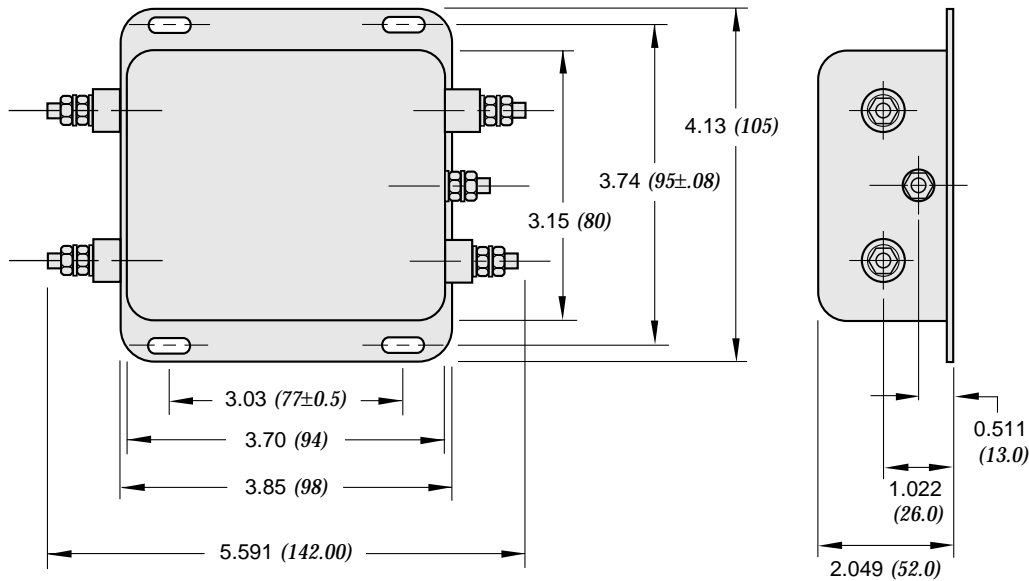

Dimensions in inches (mm)

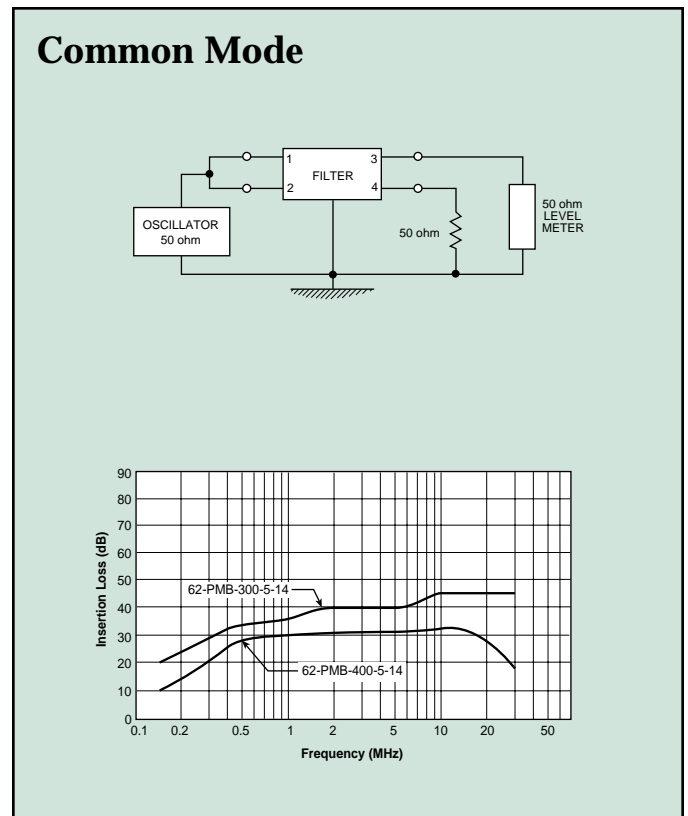
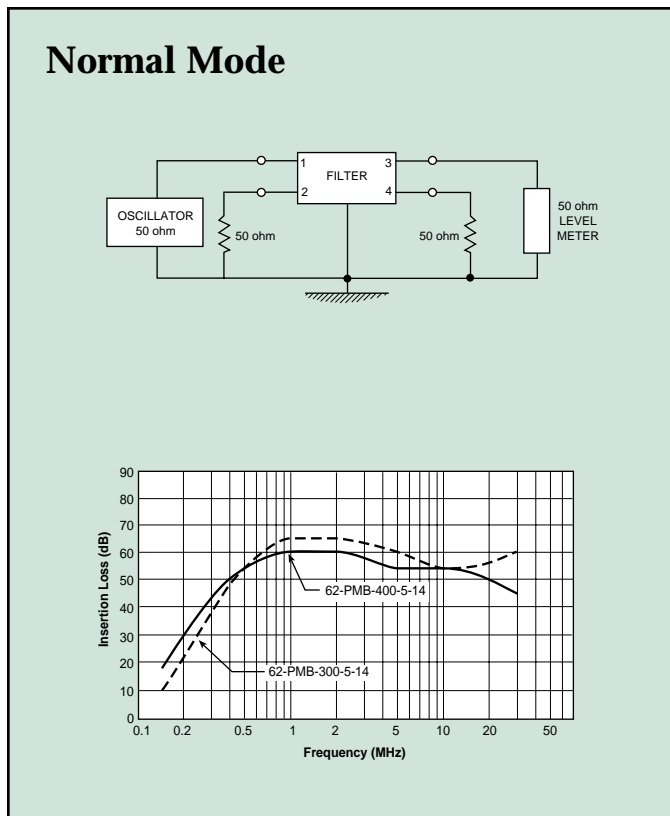

Power Line Filters Single Stage - Higher Current

12-PMB Series

Features

- Space-saving, compact designs
- Suitable for products that must conform to FCC regulations
- Excellent attenuation for high voltage impulse
- Metal case provides effective shielding
- Excellent filtering characteristics for both normal mode and common mode
- Epoxy molded for internal component reliability
- Structure provides effective shielding for noise generated externally and internally
- Designed to be in accordance with VDE 0565 Part 3
- Operating temperature: -40°C to +85°C

Applications

- Digital equipment
- Computers and peripherals
- Measuring instruments
- Medical equipment
- Equipment requiring very high impulse attenuation
- Factory automation equipment
- Industrial equipment such as UPS, inverters and converters
- Telecommunications equipment
- Office automation equipment, such as copy and fax machines



Circuit Diagram

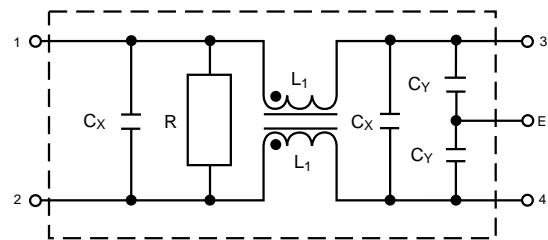

Specifications

Model	Rated Voltage (@ 50/60Hz)	Rated Current	Leakage Current (Max.)	Circuit Diagram	Figure	Temperature Rise (Max.)
12-PMB-025-5-A	120/250VAC	25A	0.5mA	1	A	30°C
12-PMB-030-5-A		30A				
12-PMB-035-5-B		35A				
12-PMB-050-5-B		50A	1.0mA			
12-PMB-100-8-C		100A				
12-PMB-120-8-C		120A				

Note: Test voltage: 1500VAC one minute, line to earth
 Insulation resistance: 300 Mohm min. at 500VDC
 Voltage drop: 1V max.
 Discharge time: 0.4 sec. max.
 Weight: 8.82 ounces (250 grams)

Power Line Filters Single Stage - Higher Current

12-PMB Series

Figure A

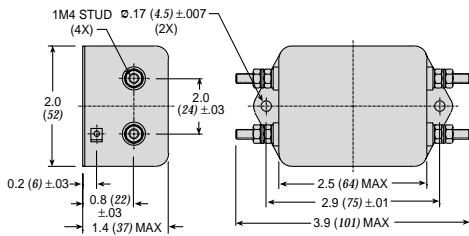

Figure B

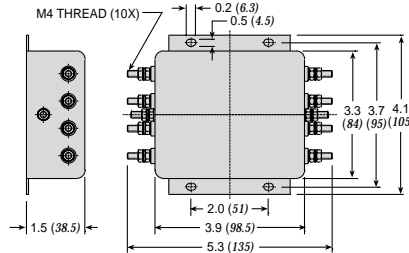
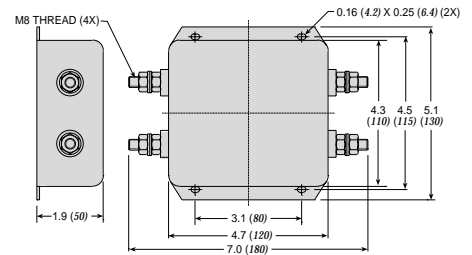
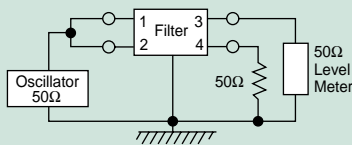

Figure C



Dimensions in inches (mm)

Common Mode



12-PMB-025;-030;-035

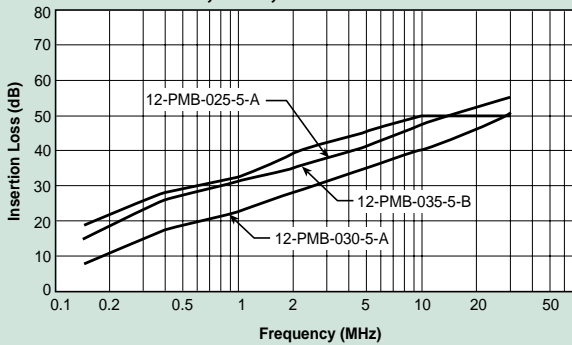

12-PMB-050;-100;-120

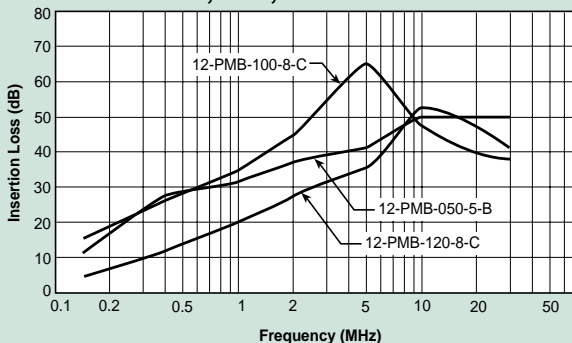

Normal Mode

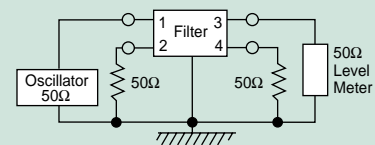

12-PMB-025;-030;-035

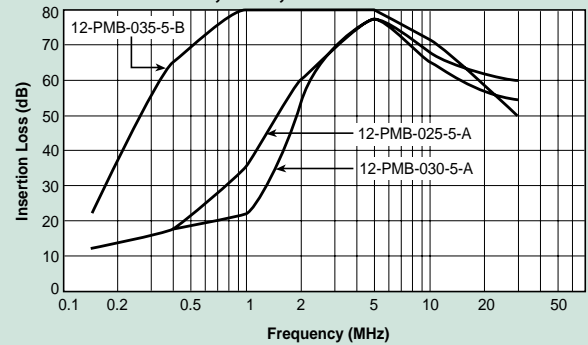

12-PMB-050;-100;-120

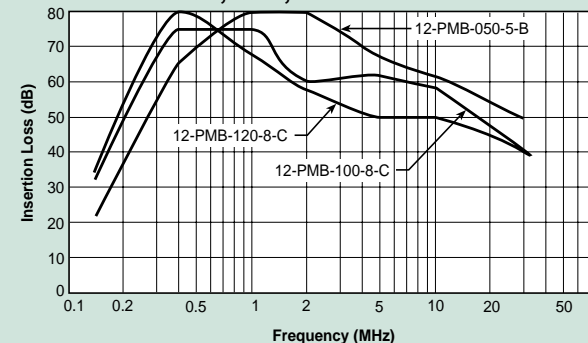

Power Line Filters DC - Higher Current

12-PMF & 12 PMB DC Series

Features

- Space-saving, compact designs
- Suitable for products that must conform to FCC regulations
- Excellent attenuation for high voltage impulse
- Metal case provides effective shielding
- Excellent filtering characteristics for both normal mode and common mode
- Epoxy molded for internal component reliability
- Structure provides effective shielding for noise generated externally and internally
- Designed to be in accordance with VDE 0565 Part 3
- Operating temperature: -40°C to +85°C

Applications

- Digital equipment
- Computers and peripherals
- Measuring instruments
- Equipment requiring very high impulse attenuation
- Factory automation equipment
- Industrial equipment such as UPS, inverters and converters
- Telecommunications equipment



Circuit Diagram

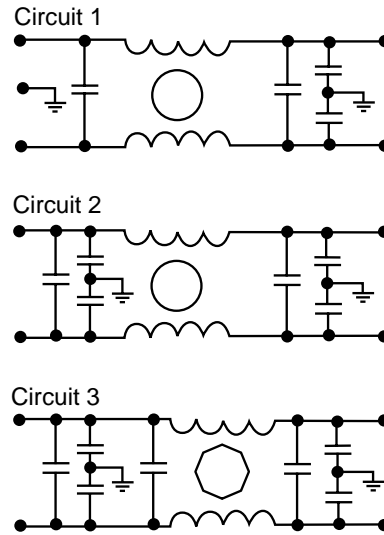

Specifications

Model	Rated Voltage (@ 50/60Hz)	Rated Current	Circuit Diagram	Figure	Temperature Rise (Max.)		
12-PMF-006-DC-C	48/250 VDC	6A	1	A	30°C		
12-PMF-010-DC-C		10A					
12-PMF-015-DC-C		15A					
12-PMF-020-DC-C		20A					
12-PMF-025-DC-D		25A				1	B
12-PMB-025-DC-F							
12-PMB-030-DC-F		30A				1	C
12-PMB-035-DC-F		35A					
12-PMB-040-DC-F		40A					
12-PMB-040-DC-B		50A				1	D
12-PMB-050-DC-B							
12-PMB-060-DC-B							
12-PMB-080-DC-G							
12-PMB-080-DC-C		80A	2	E			
12-PMB-100-DC-C		100A	3			F	
12-PMB-120-DC-C		120A					
12-PMB-140-DC-C		140A					
12-PMB-180-DC-E		180A	2	G			
12-PMB-200-DC-E		200A					
12-PMB-260-DC-E		260A					

Note: Test voltage: 1500VAC one minute, line to earth
Insulation resistance: 300 Mohm min. at 500VDC
Voltage drop: 1V max.

Discharge time: 0.4 sec. max.
Weight: 8.82 ounces (250 grams)

Power Line Filters DC - Higher Current

12-PMF & 12-PMB DC Series

Figure B

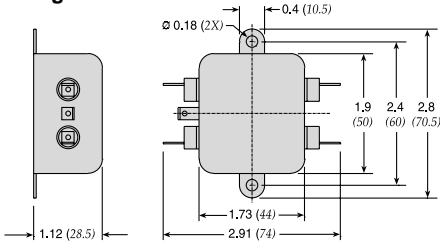

Figure C

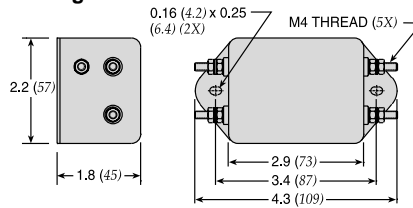

Figure A

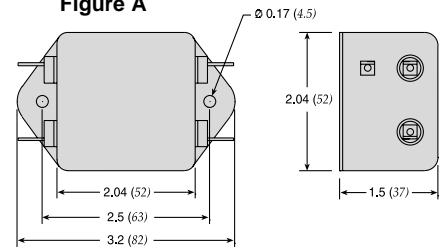

Figure D

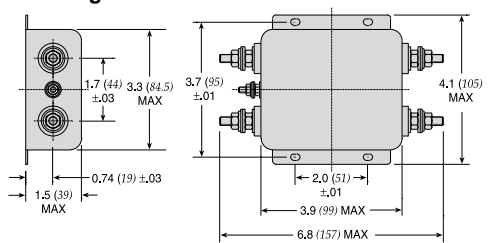

Figure E

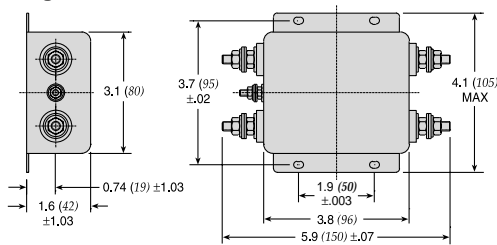

Figure F

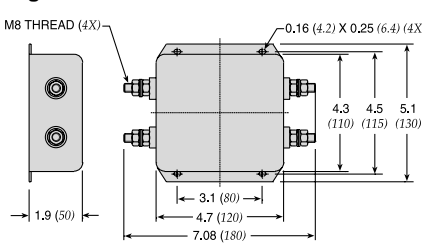
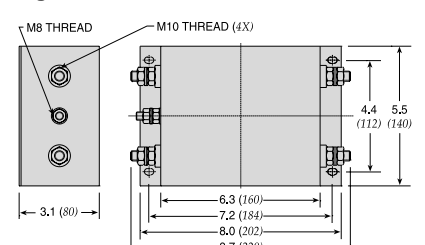
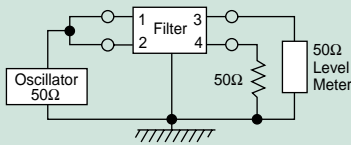

Figure G



Dimensions in inches (mm)

Common Mode



12-PMF-006;-010;-015;-020;-025

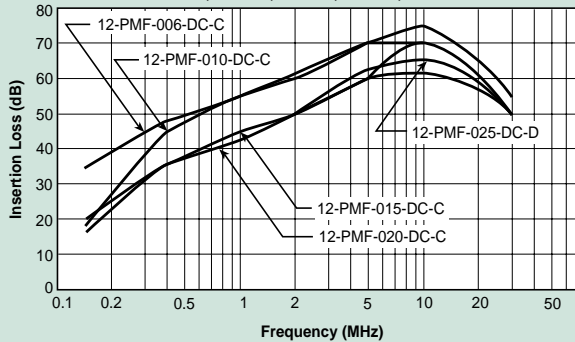

12-PMB-025; thru -260

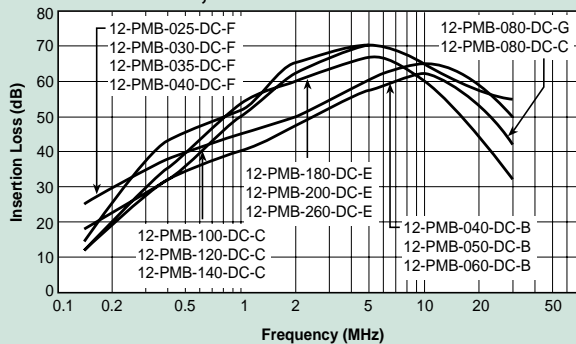

Normal Mode

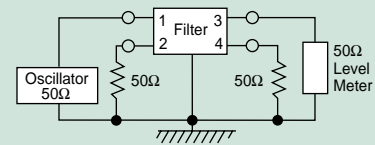

12-PMF-006;-010;-015;-020;-025

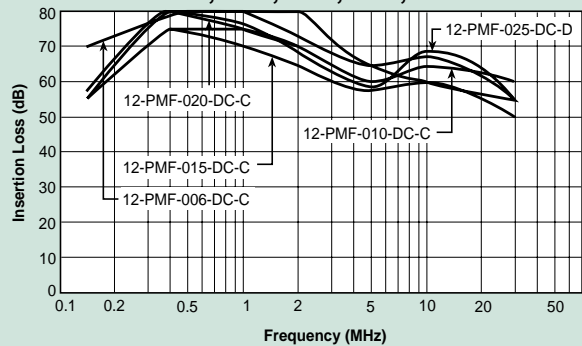

12-PMB-025; thru -260

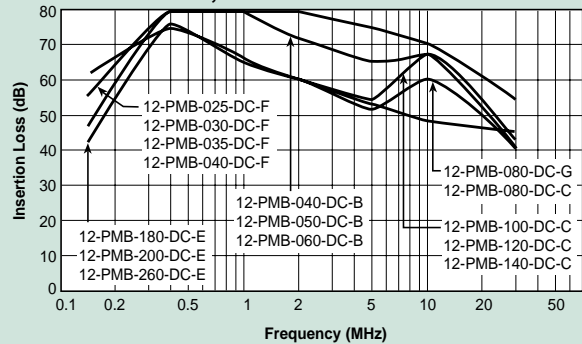

Power Line Filters Dual Stage

62-MMF Series

Features

- Suitable for products that must conform to FCC regulations
- Excellent attenuation for high voltage impulse
- Metal case provides effective EMI shielding
- Two stages for excellent filtering characteristics
- Epoxy molded for reliability
- Structure provides effective shielding for noise generated both externally and internally
- Operating temperature: -25°C to +85°C (including temperature rise, see graph on page 81)

Applications

- Digital equipment
- Personal computers and peripherals
- Measuring instruments and medical equipment
- Telecommunications equipment
- Equipment requiring very high noise attenuation



Circuit Diagram

62-MMF-XXX-7-11

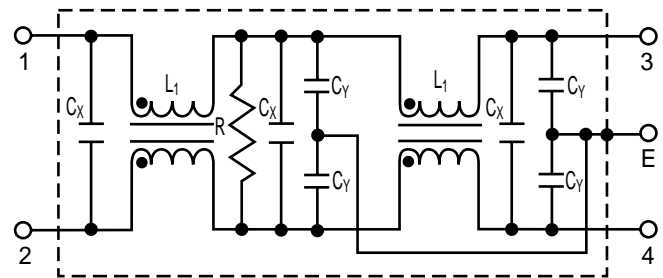

Specifications

Model	Rated Voltage (@ 50/60Hz)	Rated Current	Leakage Current (Max.)	Capacitance			Inductance (L ₁) (2X)	Temperature Rise (Max.)
				C _{Y1}	C _{Y2}	C _X		
62-MMF-030-7-11	250VAC	3A	.7mA	3300pF	1000pF	0.1uF	3.7mH	30°C
62-MMF-050-7-11	250VAC	5A	.7mA	3300pF	1000pF	0.1uF	2.9mH	30°C

Note: All types are designed to meet the requirement of UL 1283, CSA 22.2, VDE 0565-3
 Test voltage: 1500VAC one minute, line to ground
 Insulation resistance: 300 Mohm min. at 500VDC
 Leakage current: 0.7 mA max.
 Voltage drop: 1V max.
 Discharge time: 0.4 sec. max.
 Weight: 6.0 ounces (170 grams)

Power Line Filters Dual Stage

62-MMF Series

Temperature Characteristics

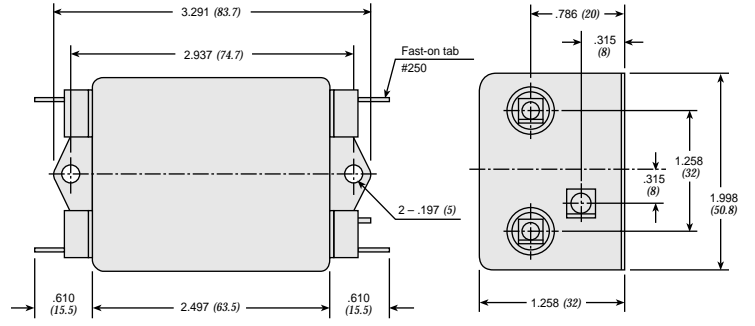
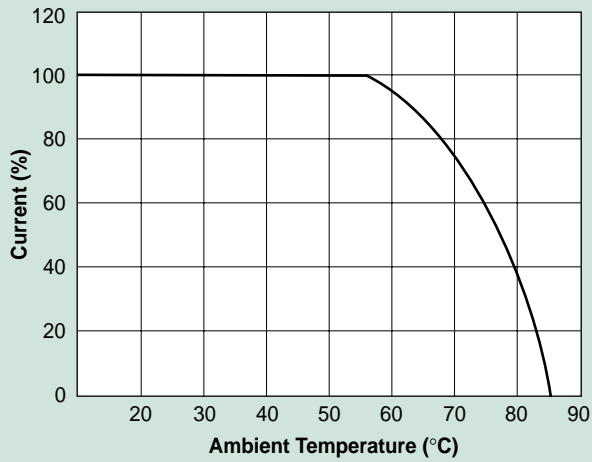

Common Mode

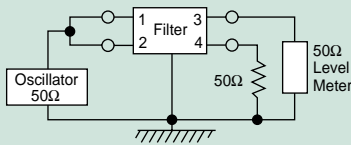

62-MMF

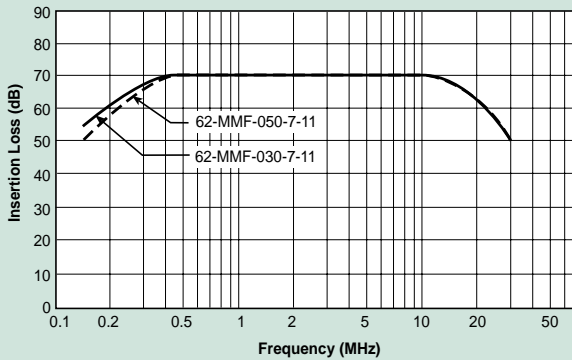

Normal Mode

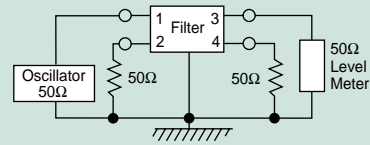

62-MMF

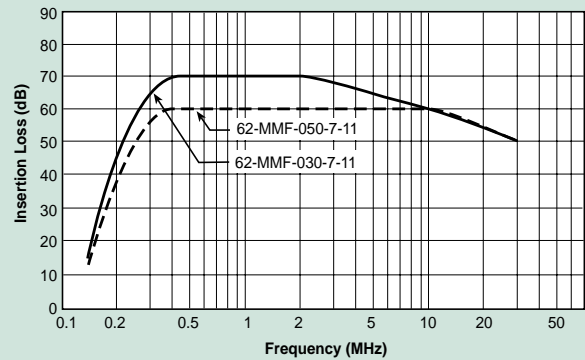

Power Line Filters Dual Stage

12-MMF & 12-MMB Series

Features

- Suitable for products that must conform to FCC regulations
- Excellent attenuation for high voltage impulse
- Metal case provides effective EMI shielding
- Two stages for excellent filtering characteristics
- Structure provides effective shielding for noise generated both externally and internally
- Operating temperature: -40°C to +85°C
- High performance
- Low leakage current

Applications

- Digital equipment
- Switching power supplies
- Personal computers and peripherals
- Measuring instruments and medical equipment
- Telecommunications equipment
- Equipment requiring very high noise attenuation



Circuit Diagram

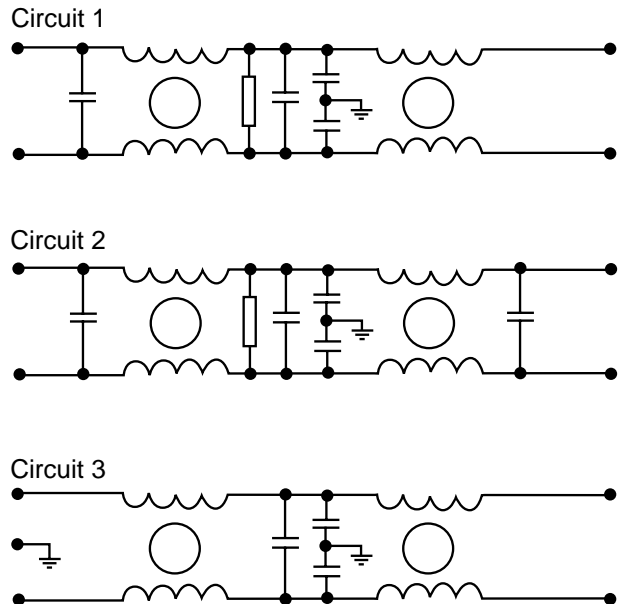

Specifications

Model	Rated Voltage (@ 50/60Hz)	Rated Current	Leakage Current (Max.)	Circuit Diagram	Figure	Temperature Rise (Max.)	
12-MMF-002-5-F	120/250VAC	2A	0.5mA	1	A	30°C	
12-MMF-003-5-F		3A			B		
12-MMF-003-5-A					C		
12-MMF-006-5-F		6A		2	B		
12-MMF-006-5-G					D		
12-MMF-008-5-B		8A			B		
12-MMF-010-5-F		10A			D		
12-MMF-010-5-G							B
12-MMF-010-5-B							D
12-MMF-012-5-B		12A			E		
12-MMB-015-5-E		15A			D		
12-MMB-020-5-F		20A			F		
12-MMB-030-5-D		30A					
12-MMB-050-5-C		50A		G			

Note: All types are designed to meet the requirement of UL 1283, CSA 22.2. VDE 0565-3
 Test voltage: 1500VAC one minute, line to ground
 Insulation resistance: 300 Mohm min. at 500VDC
 Leakage current: 0.7 mA max.
 Voltage drop: 1V max.
 Discharge time: 0.4 sec. max.

Power Line Filters Dual Stage

12-MMF & 12-MMB Series

Figure A

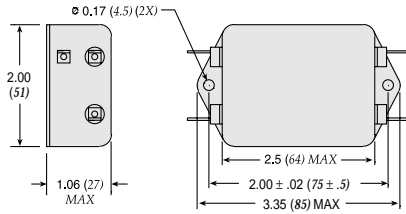

Figure B

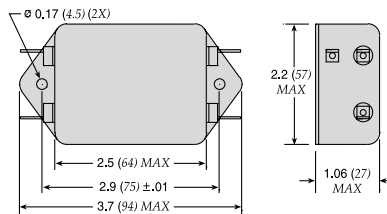

Figure C

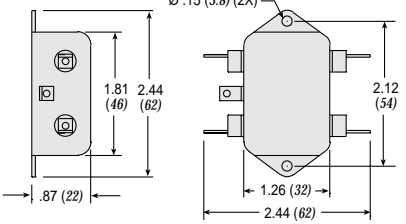

Figure D

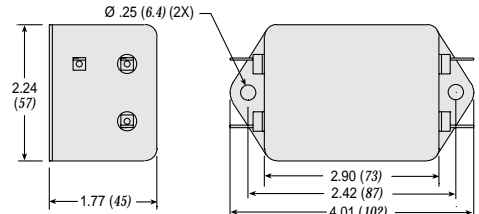

Figure E

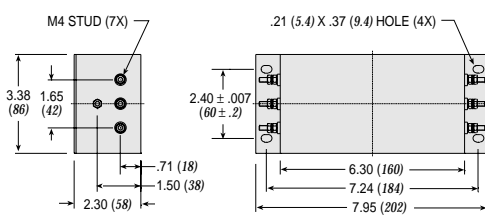

Figure F

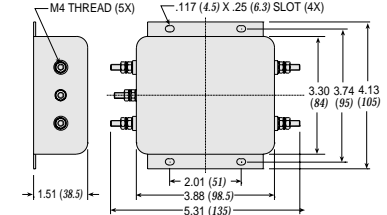
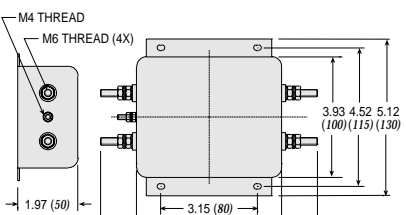
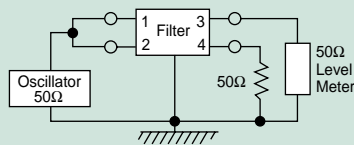

Figure G



Dimensions in inches (mm)

Common Mode



12-MMF-002;-003;-006;-008

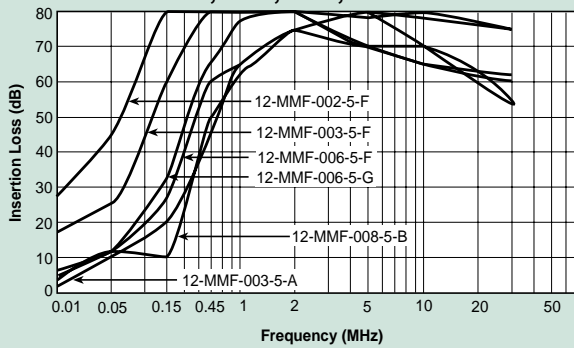

12-MMF-010;-012;-015;-020;-030;-050

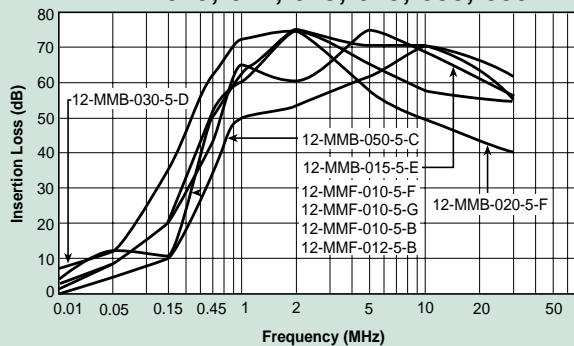

Normal Mode

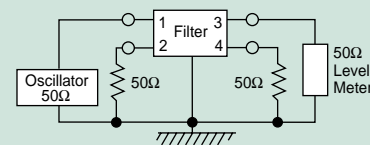

12-MMF-002;-003;-006;-008

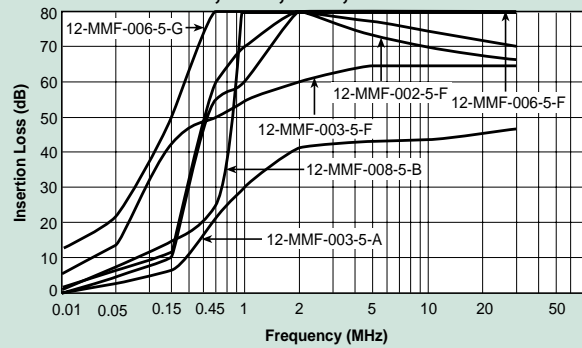

12-MMF-010;-012;-015;-020;-030;-050

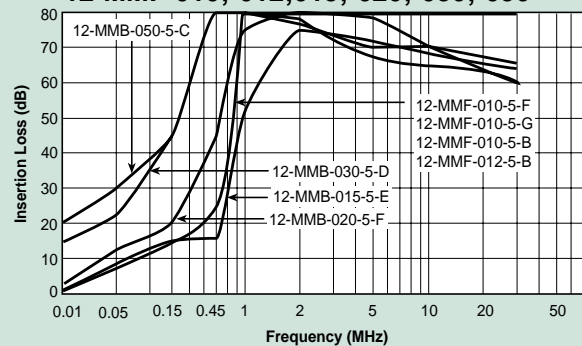

Power Line Filters Dual Stage

12-MMF & 12-MMB Series

Features

- Suitable for products that must conform to FCC regulations
- Excellent attenuation for high voltage impulse
- Metal case provides effective EMI shielding
- Two stages for excellent filtering characteristics
- Structure provides effective shielding for noise generated both externally and internally
- Operating temperature: -40°C to +85°C
- High performance

Applications

- Digital equipment
- Personal computers and peripherals
- Measuring instruments and medical equipment
- Telecommunications equipment
- Equipment requiring very high noise attenuation



Circuit Diagram

Circuit 1

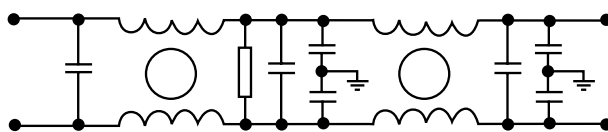

Circuit 2

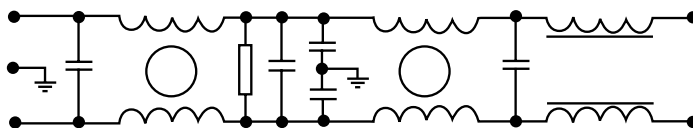

Specifications

Model	Rated Voltage (@ 50/60Hz)	Rated Current	Leakage Current (Max.)	Circuit Diagram	Figure	Temperature Rise (Max.)
12-MMF-003-11-F	120/250VAC	3A	1.5mA	1	A	30°C
12-MMF-006-11-F		6A			B	
12-MMF-010-11-F		10A			C	
12-MMB-012-11-A		12A		1	B	
12-MMB-015-11-G		15A			B	
12-MMB-020-11-D		20A		2	D	
12-MMB-030-11-D		30A			D	
12-MMB-040-11-B		40A		1	E	
12-MMB-040-11-E		40A			E	
12-MMB-050-11-H		50A		1	F	

Note: All types are designed to meet the requirement of UL 1283, CSA 22.2. VDE 0565-3

Test voltage: 1500VAC one minute, line to ground
 Insulation resistance: 300 Mohm min. at 500VDC
 Leakage current: 0.7 mA max.
 Voltage drop: 1V max.
 Discharge time: 0.4 sec. max.
 Weight: 6.0 ounces (170 grams)

Power Line Filters Dual Stage

12-MMF & 12-MMB Series

Figure A

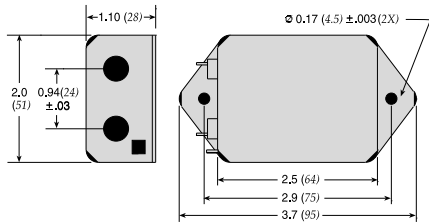

Figure B

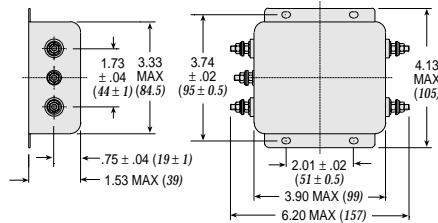

Figure C

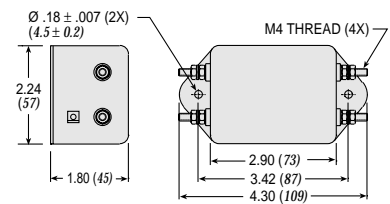

Figure D

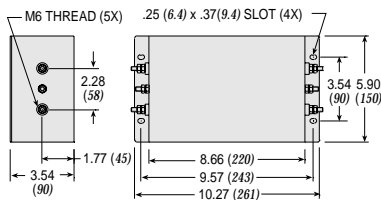

Figure E

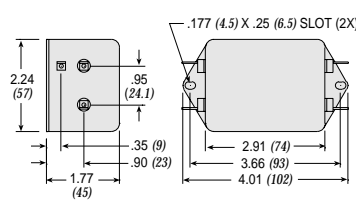
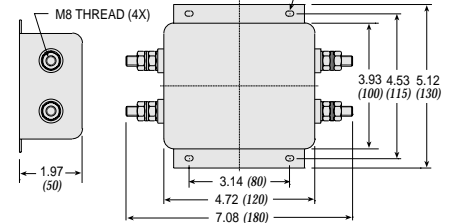
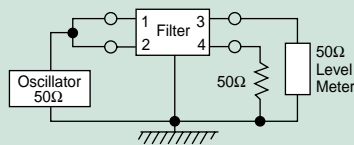

Figure F



Dimensions in inches (mm)

Common Mode



12-MMF-003;-006;-010;-012;-015

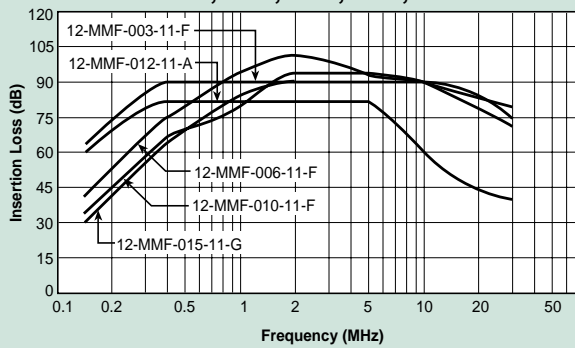

12-MMF-020;-030;-040;-050

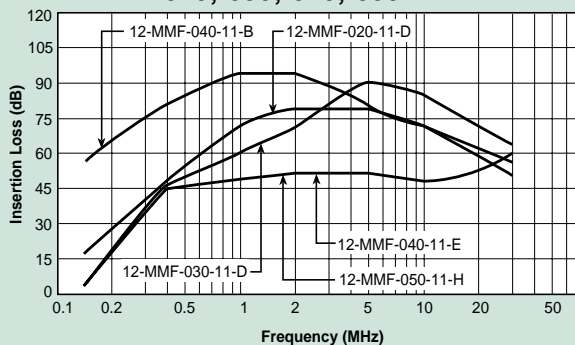

Normal Mode

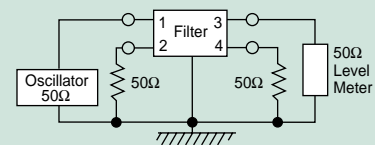

12-MMF-003;-006;-010;-012;-015

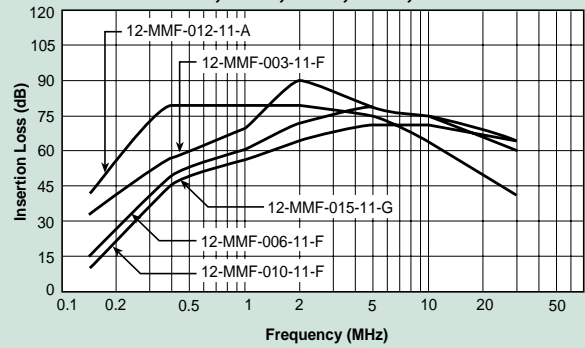

12-MMF-020;-030;-040;-050

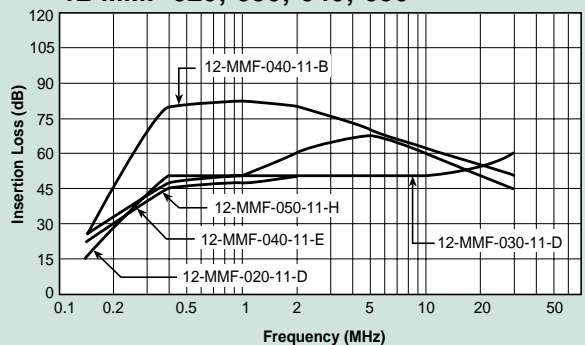

Power Line Filters Dual Stage

12-MMF & 12-MMB Series

Features

- Suitable for products that must conform to FCC regulations
- Excellent attenuation for high voltage impulse
- Metal case provides effective EMI shielding
- Two stages for excellent filtering characteristics
- Epoxy molded for reliability
- Structure provides effective shielding for noise generated both externally and internally
- Operating temperature: -25°C to +85°C

Applications

- Digital equipment
- Personal computers and peripherals
- Measuring instruments and medical equipment
- Telecommunications equipment
- Equipment requiring very high noise attenuation



Circuit Diagram

Circuit 1

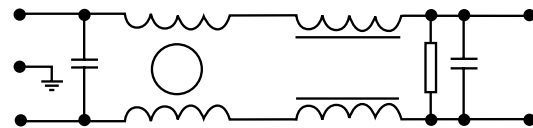

Circuit 2

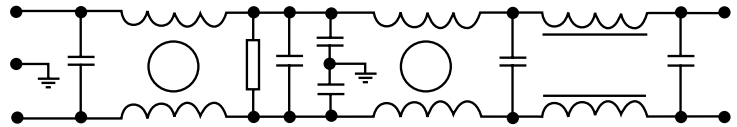

Circuit 3

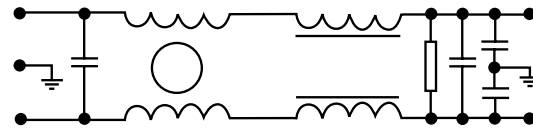

Specifications

Model	Rated Voltage (@ 50/60Hz)	Rated Current	Leakage Current (Max.)	Circuit Diagram	Figure	Temperature Rise (Max.)
12-MMF-001-5-F	120/250VAC	1A	0.5mA	3	A	30°C
12-MMF-003-5-G		3A			5uA	
12-MMF-003-2-G			6A	0.5mA		
12-MMF-006-5-G		10A	D			
12-MMB-010-5-D		15A				
12-MMB-015-5-E		20A				
12-MMB-020-5-E		30A				
12-MMB-030-5-E						

Note: All types are designed to meet the requirement of UL 1283, CSA 22.2. VDE 0565-3

Test voltage: 1500VAC one minute, line to ground

Insulation resistance: 300 Mohm min. at 500VDC

Leakage current: 0.7 mA max.

Voltage drop: 1V max.

Discharge time: 0.4 sec. max.

Weight: 6.0 ounces (170 grams)

Power Line Filters Dual Stage

12-MMF & 12-MMB Series

Figure A

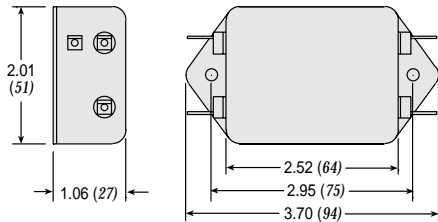

Figure B

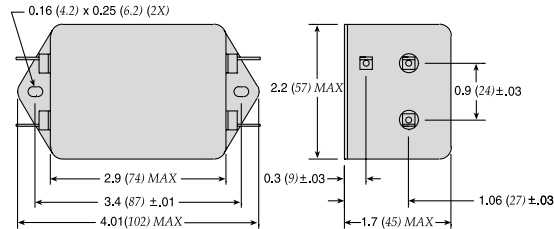

Figure C

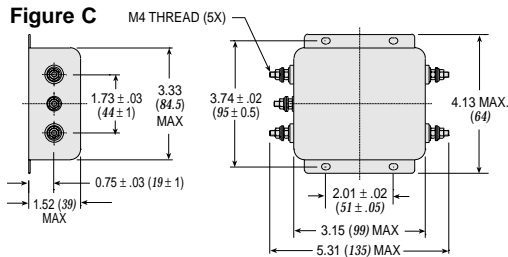
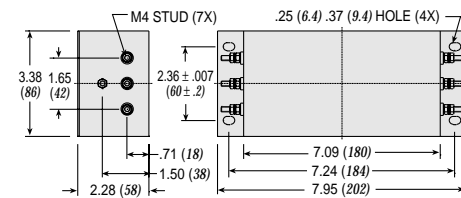
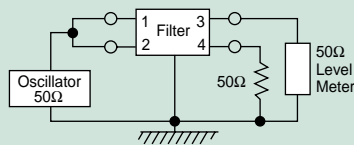

Figure D



Dimensions in inches (mm)

Common Mode



12-MMF-001;-003;-006

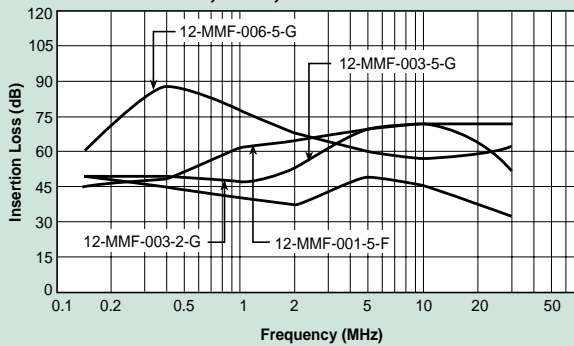

12-MMB-010;-015;-020;-030

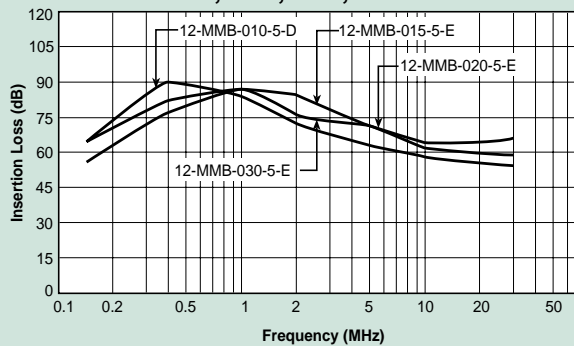

Normal Mode

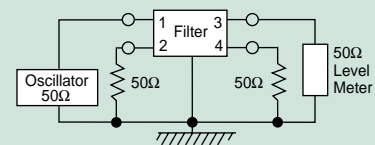

12-MMF-001;-003;-006

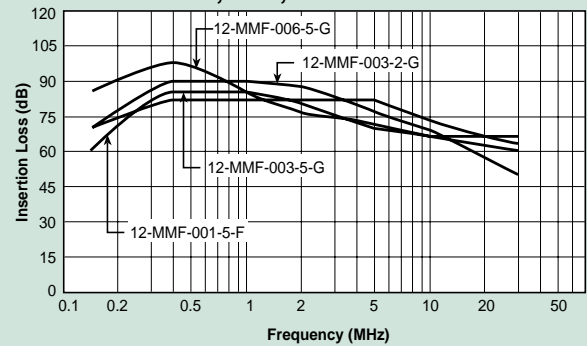

12-MMB-010;-015;-020;-030

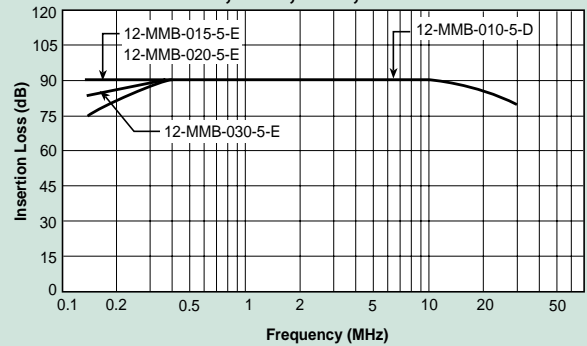

Power Line Filters

Three Phase

Low Current/High Performance



62-PMB/63-PMF Series

Features

- Excellent attenuation for high voltage impulse
- Effective for both balanced and unbalanced three-phase loads
- Metal case provides effective EMI shielding
- Epoxy molded for internal component reliability
- Compact and economical
- Excellent filtering characteristics for both normal and common mode
- Various current ratings available: 3, 5, 8 and 16 Amps
- Safety agency approvals pending
- Operating temperature: -25°C to +85°C (including temperature rise, see graph on page 89)

Applications

- Digital equipment
- Industrial equipment (UPS, inverters and converters)
- Automation equipment
- Computerized washing machines

Circuit Diagram

62-PMB-050-6-12 (5 Amp Delta)

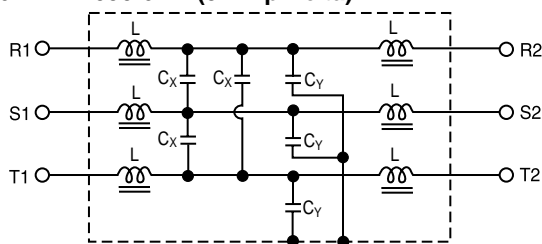

63-PMF-030-8-14 and 63-PMF-080-8-14 (3 and 8 Amp Wye)

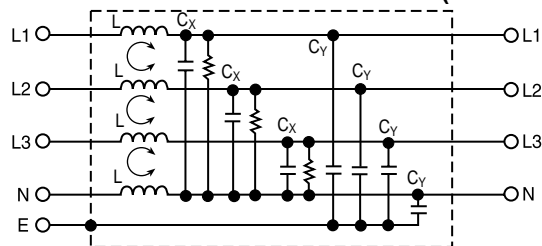

63-PMF-160-9-21 (16 Amp Wye)

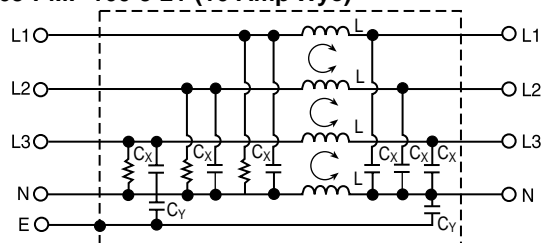

Specifications

Model	Rated Voltage (@ 50/60Hz)	Rated Current	Leakage Current (Max.)	Capacitance		Inductance (L ₁)	Temperature Rise (Max.)
				C _Y	C _X		
62-PMB-050-6-12	250VAC	5A	0.6mA	2200pF	0.22uF	115mH	45°C
63-PMF-030-8-14	420VAC	3A	1.0mA	4700pF (4X)	470uF (3X)	1.0mH (4X)	30°C
63-PMF-080-8-14		8A				0.74mH (4X)	40°C
63-PMF-160-9-21		16A	3.0mA	0.015uF (2X)	1.0uF (6X)	1.2mH (4X)	45°C

Note: Test Voltage 1500VAC one minute, line to ground.
 Insulation Resistance: 300 MΩ min. at 500VDC.
 Voltage Drop: 1V max. at rated current.
 Weight: 8.82 ounces (250 grams) for 63-PMF-030-8-14 and 63-PMF-080-8-14
 19.4 ounces (550 grams) for 62-PMB-050-6-12
 51.5 ounces (1450 grams) for 63-PMF-160-9-21

Power Line Filters

Three Phase

Low Current/High Performance

62-PMB/63-PMF Series

62-PMB-050-6-12 (5 Amp)

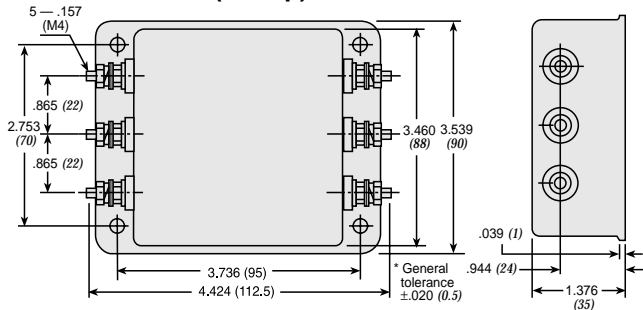

63-PMF-030-8-14 and 63-PMF-080-8-14 (3 and 8 Amp)

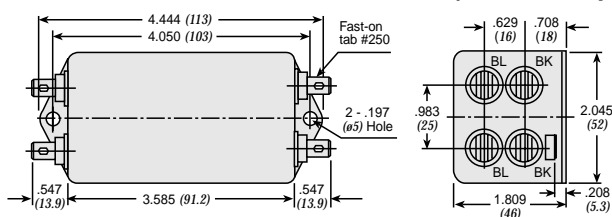

Dimensions in inches (mm)

63-PMF-160-9-21 (16 Amp)

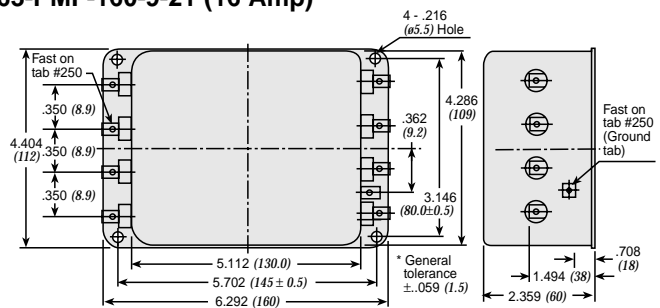

Temperature Characteristics

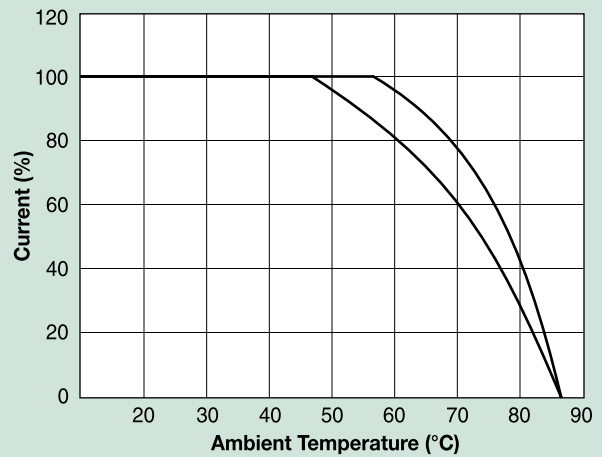

Common Mode

62-PMB-050-6-12 (5 Amp)

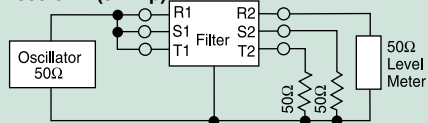

63-PMF (3, 8 and 16 Amp)

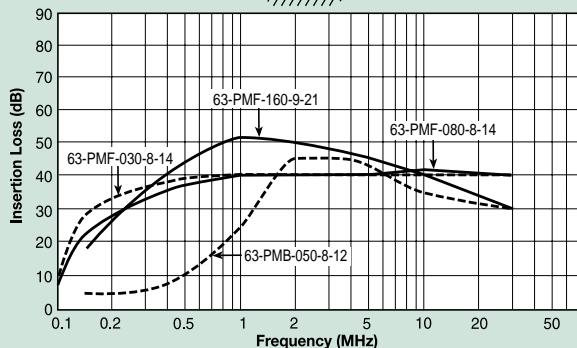
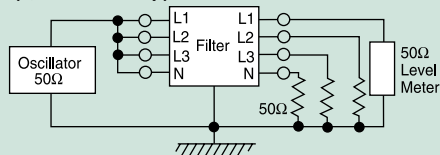

Normal Mode

62-PMB-050-6-12 (5 Amp)

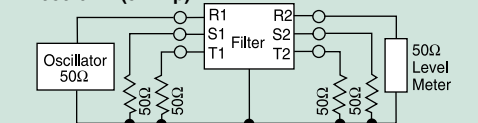

63-PMF (3, 8 and 16 Amp)

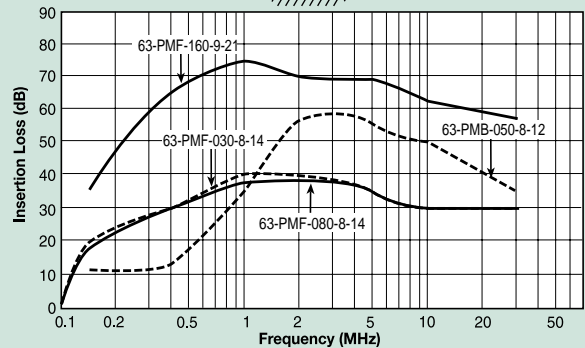
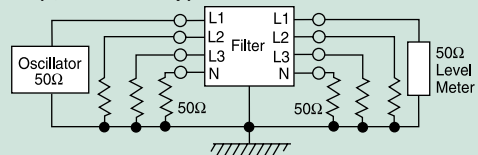

Power Line Filters Three Phase

13-PWF/PWL/PWB Series

Features

- Excellent attenuation for high voltage impulse
- Effective for both balanced and unbalanced three-phase loads
- Metal case provides effective EMI shielding
- Epoxy molded for internal component reliability
- Suitable for both Wye and Delta connection
- Excellent filtering characteristics for both normal and common mode
- Operating temperature: -40°C to +85°C
- Designed for 3-phase 4-line power supply systems

Applications

- Digital equipment
- Industrial equipment (UPS, inverters and converters)
- Automation equipment
- Computerized washing machines



Circuit Diagram

Circuit 1

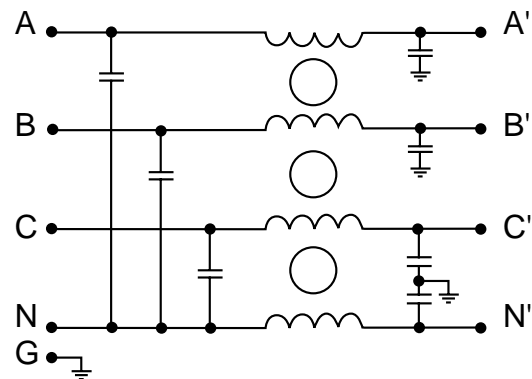

Circuit 2

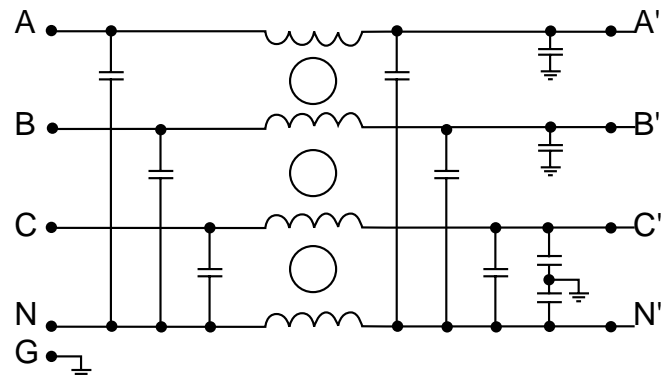

Specifications

Model	Rated Voltage (@ 50/60Hz)	Rated Current	Leakage Current (Max.)	Circuit Diagram	Figure	Temperature Rise (Max.)	
13-PWF-005-12-H	440/250VAC	5A	1.5mA	1	A	30°C	
13-PWL-005-12-C					B		
13-PWF-010-12-H					A		
13-PWL-010-12-C					B		
13-PWB-010-12-D		15A			2		C
13-PWB-015-12-D							
13-PWB-020-12-D					25A		
13-PWB-025-12-D							
13-PWB-030-12-D				30A			

Note: Test Voltage 1500VAC one minute, line to ground.
Insulation Resistance: 300 MΩ min. at 500VDC.
Voltage Drop: 1V max. at rated current.

Power Line Filters Three Phase

13-PWF/PWL/PWB Series

Figure A

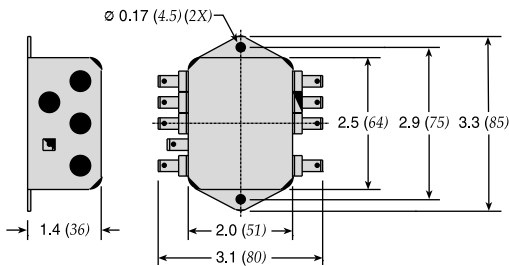

Dimensions in inches (mm)

Figure B

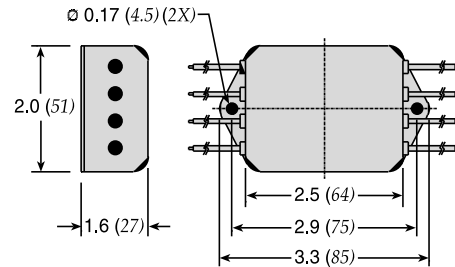
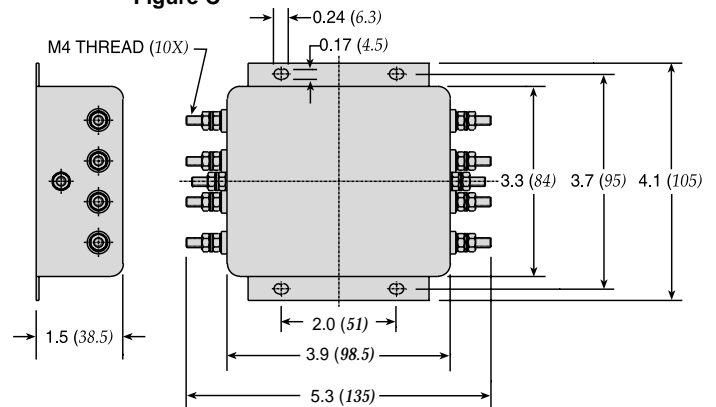
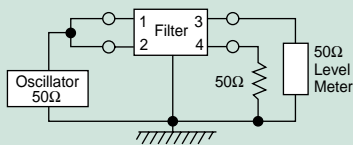

Figure C



Common Mode



13-PWF-005;-010;-PWL-005;-010;-PWB-010

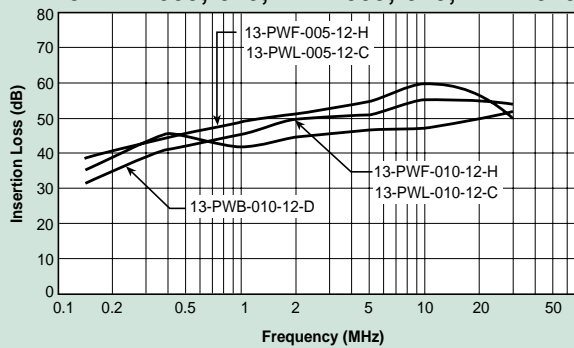

13-PWB-015;-020;-025;-030

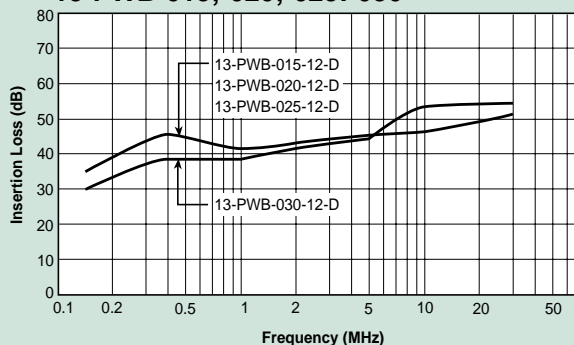

Normal Mode

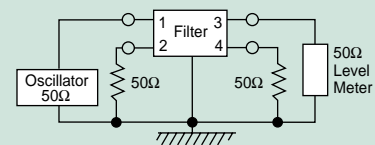

13-PWF-005;-010;-PWL-005;-010;-PWB-010

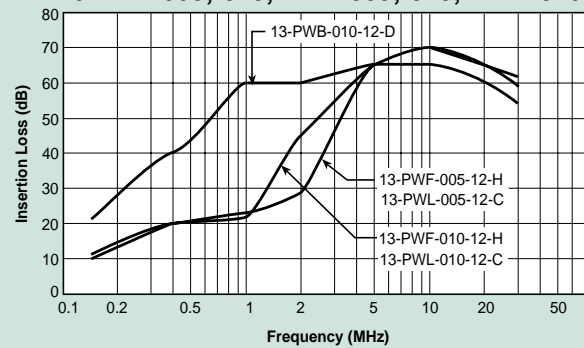

13-PWB-015;-020;-025;-030

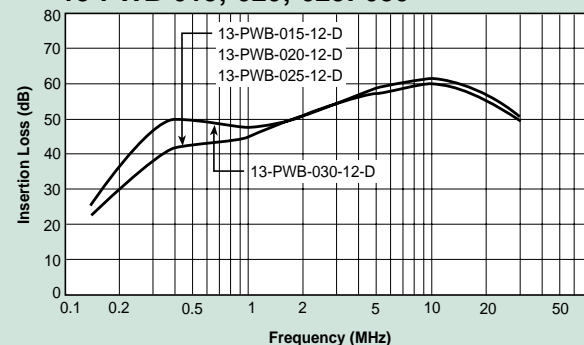

Power Line Filters Three Phase

13-PDF/PDL/PDB Series

Features

- Excellent attenuation for high voltage impulse
- Effective for both balanced and unbalanced three-phase loads
- Metal case provides effective EMI shielding
- Epoxy molded for internal component reliability
- Compact and economical
- Excellent filtering characteristics for both normal and common mode
- Operating temperature: -40°C to +85°C
- Designed for 3-phase, 3-Delta connection system

Applications

- Digital equipment
- Industrial equipment (UPS, inverters and converters)
- Automation equipment
- Switching power supplies



Circuit Diagram

Circuit 1

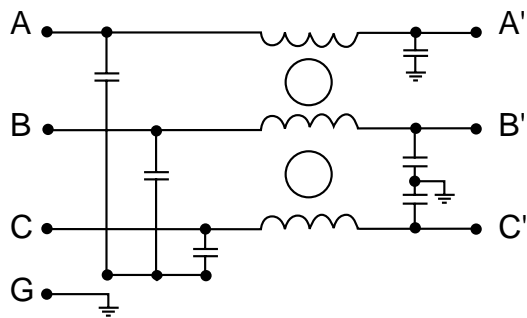

Circuit 2

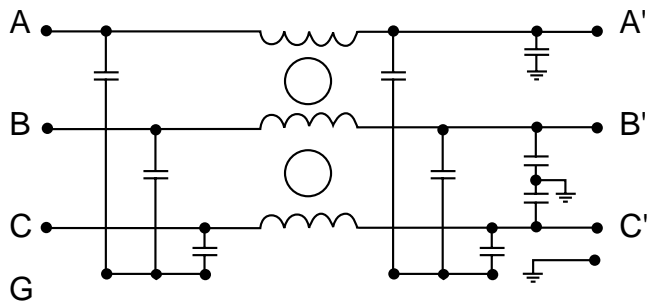

Specifications

Model	Rated Voltage (@ 50/60Hz)	Rated Current	Leakage Current (Max.)	Circuit Diagram	Figure	Temperature Rise (Max.)
13-PDF-005-11-J	440/250VAC	5A	1.5mA	1	A	30°C
13-PDL-005-11-D					B	
13-PDF-010-11-J		10A			A	
13-PDL-010-11-D					B	
13-PDB-010-11-D		15A		2	C	
13-PDB-015-11-D						
13-PDB-020-11-D						
13-PDB-025-11-D						
13-PDB-030-11-D	30A					

Note: Test Voltage 1500VAC one minute, line to ground.
 Insulation Resistance: 300 MΩ min. at 500VDC.
 Voltage Drop: 1V max. at rated current.

Power Line Filters Three Phase

13-PDF/PDL/PDB Series

Figure A

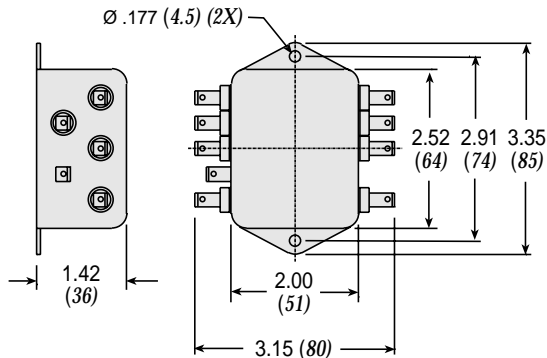

Dimensions in inches (mm)

Figure B

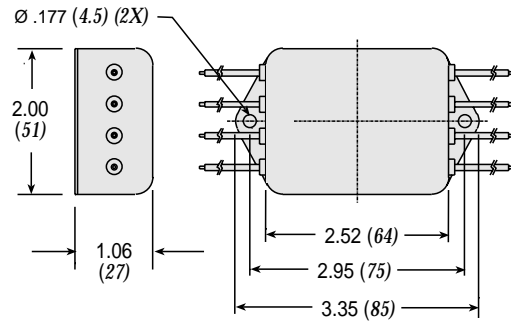
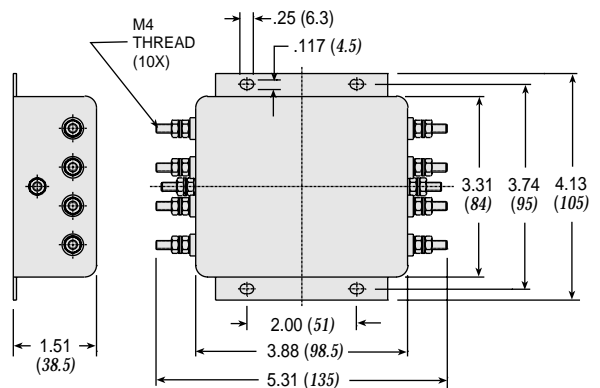
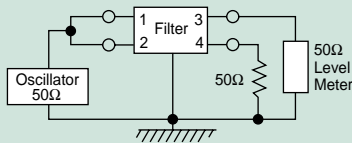

Figure C



Common Mode



13-PDF-005;-010; PDL-005;-010 PDB-010

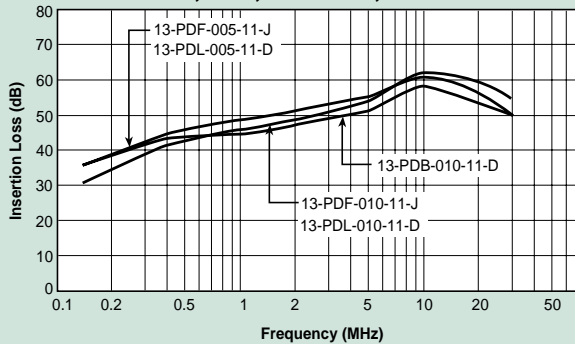

13-PDB-015;-020;-025;-030

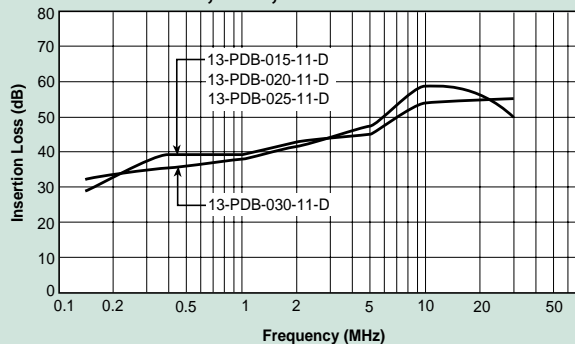

Normal Mode

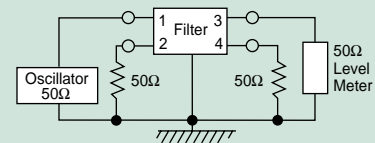

13-PDF-005;-010; PDL-005;-010 PDB-010

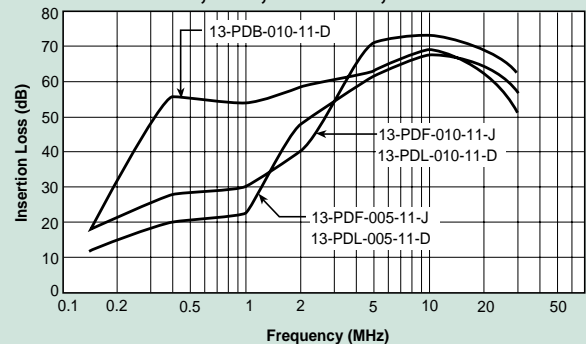

13-PDB-015;-020;-025;-030

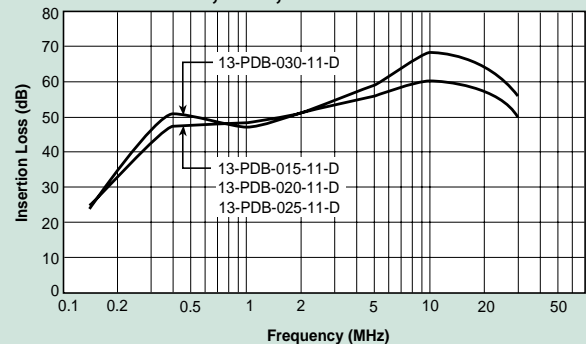

Power Line Filters

Three Phase

High Performance

13-PWB Series

Features

- Excellent attenuation for high voltage impulse
- Metal case provides effective EMI shielding
- Epoxy molded for internal component reliability
- Excellent filtering characteristics for both normal and common mode
- Various current ratings available: from 5 to 150 Amps
- Operating temperature: -40°C to +85°C
- Designed for 3-phase, 4-line power systems

Applications

- Power supplies for data systems
- Industrial equipment (UPS, inverters and converters)
- Automation equipment
- Telecommunications systems and equipment



Circuit Diagram

Circuit 1

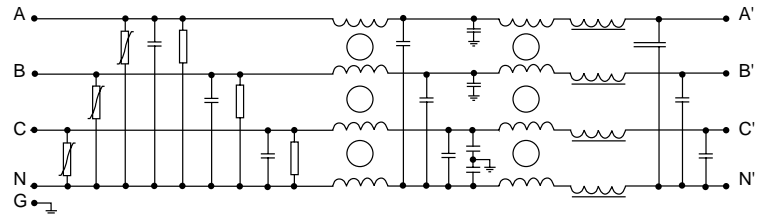

Circuit 2

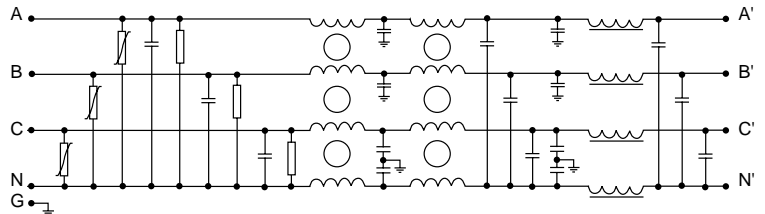

Specifications

Model	Rated Voltage (@ 50/60Hz)	Rated Current	Leakage Current (Max.)	Circuit Diagram	Temperature Rise (Max.)
13-PWB-005-12-A	440/250VAC	5A	4.5mA	1	30°C
13-PWB-010-12-B		10A			
13-PWB-020-12-B		20A			
13-PWB-035-12-C		35A			
13-PWB-050-13-C		50A	9.0mA	2	
13-PWB-080-14-D		80A			
13-PWB-100-14-D		100A			
13-PWB-150-14-E		150A	20mA		

Note: Test Voltage 1500VAC one minute, line to ground.
 Insulation Resistance: 300 MΩ min. at 500VDC.
 Voltage Drop: 1V max. at rated current.

Power Line Filters

Three Phase

High Performance

13-PWB Series

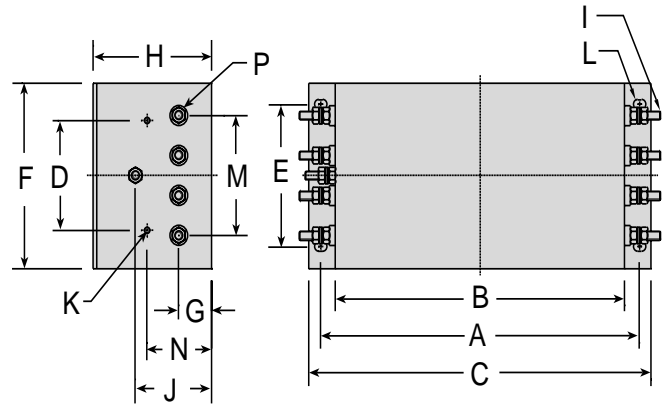

Dimensions

Dimensions in inches (mm)

Model	A	B	C	D	E	F	G	H	I	J	K	M	N	P	L
13-PWB-005-12-A	7.2 (184)	6.3 (160)	7.9 (202)	2.4 (60)	1.7 (44)	3.5 (86)	.70 (18)	2.3 (58)	M4	1.5 (38)	-	-	-	M4	.25 x .37 (6.4 x 9.4)
13-PWB-010-12-B	9.6 (243)	8.7 (220)	10.3 (261)			3.9 (100)	.98 (25)			3.5 (90)					1.8 (45)
13-PWB-020-12-B				2.3 (58)	2.9 (74)	1.9 (49)		M6	.25 x .38 (6.4 x 9.6)						
13-PWB-035-12-C				2.4 (62)	3.4 (86)	2.2 (56)		M8	.25 x .38 (6.4 x 9.7)						
13-PWB-050-13-C	13.9 (354)	12.6 (320)	15.1 (384)	3.9 (99)	6.1 (155)	7.3 (185)	1.2 (30)	3.9 (100)	M8	M4	M4	3.4 (86)	2.4 (61)	M8	.25 x .39 (6.4 x 9.9)
13-PWB-080-14-D															.25 x .36 (6.4 x 9.10)
13-PWB-100-14-D															.25 x .36 (6.4 x 9.11)
13-PWB-150-14-E															

Common Mode

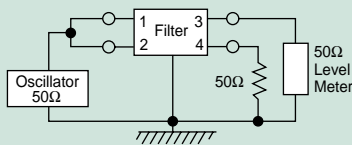

13-PWB-005;-010;-020;-035

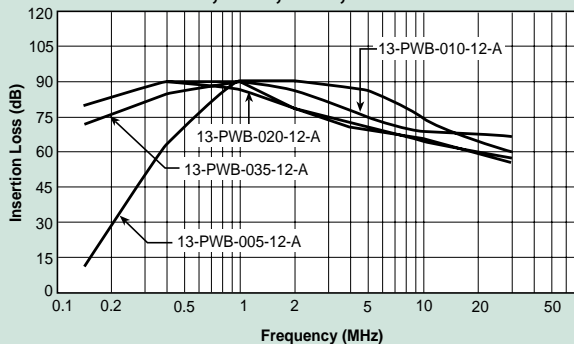

13-PWB-050;-080;-100;-150

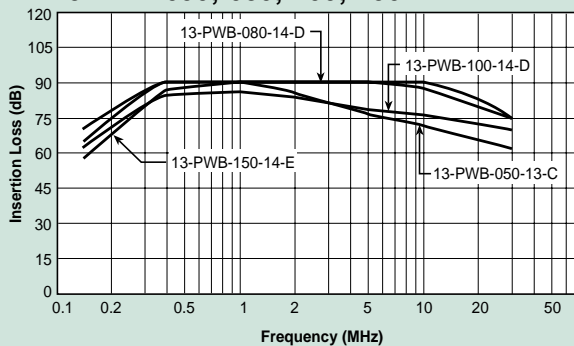

Normal Mode

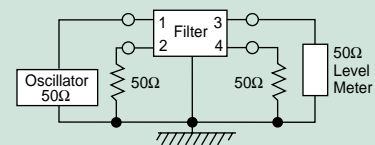

13-PWB-005;-010;-020;-035

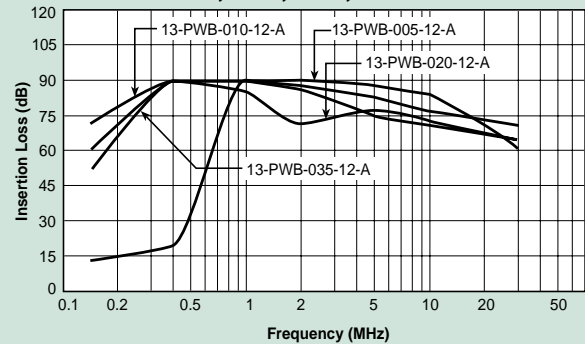

13-PWB-050;-080;-100;-150

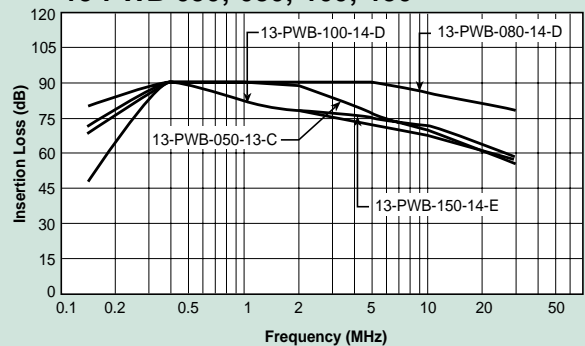

Power Line Filters

Three Phase

High Performance

13-PDB Series

Features

- Excellent attenuation for high voltage impulse
- Metal case provides effective EMI shielding
- Epoxy molded for internal component reliability
- Excellent filtering characteristics for both normal and common mode
- Various current ratings available: from 5 to 200 Amps
- Operating temperature: -40°C to +85°C
- Designed for 3-phase, 3-line connection systems

Applications

- Digital equipment
- Industrial equipment (UPS, inverters and converters)



Circuit Diagram

Circuit 1

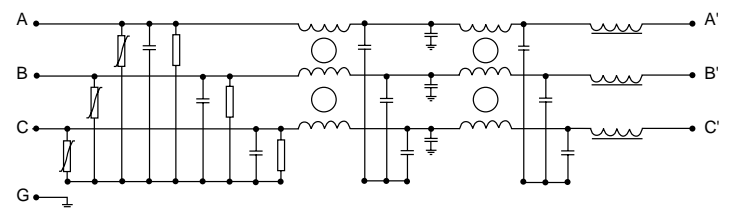

Circuit 2

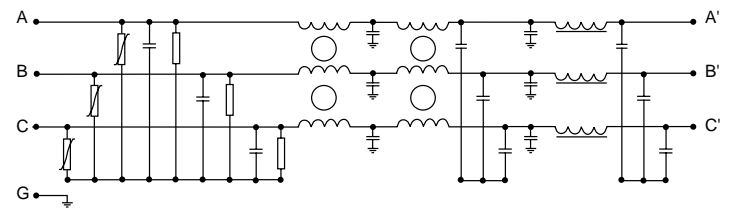

Specifications

Model	Rated Voltage (@ 50/60Hz)	Rated Current	Leakage Current (Max.)	Circuit Diagram	Temperature Rise (Max.)
13-PDB-005-12-A	440/250VAC	5A	4.5mA	1	30°C
13-PDB-010-12-A		10A			
13-PDB-020-12-B		20A			
13-PDB-035-12-B		35A			
13-PDB-050-13-B		50A			
13-PDB-080-13-C		80A	9.0mA	2	
13-PDB-100-14-C		100A			
13-PDB-150-14-C		150A			
13-PDB-200-14-D		200A			

Note: Test Voltage 2250VDC one minute, line to ground.
Insulation Resistance: 500MΩ.

Power Line Filters

Three Phase

High Performance

13-PDB Series

Dimensions

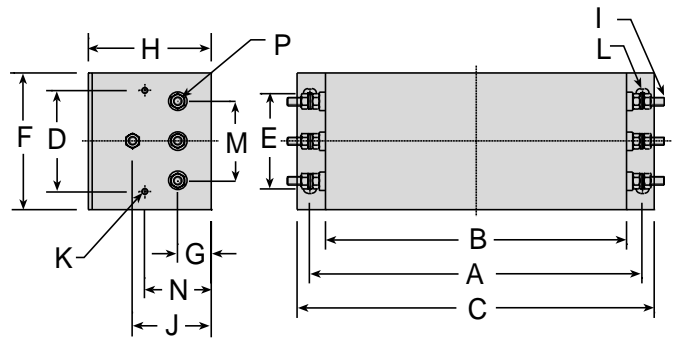

Dimensions in inches (mm)

Model	A	B	C	D	E	F	G	H	I	J	K	M	N	P	L								
13-PDB-005-12-A	7.2 (184)	6.3 (160)	7.9 (202)	1.6 (42)	2.4 (60)	3.3 (86)	.70 (18)	2.3 (58)	M4	1.5 (38)	-	-	-	M4	.25 x .37 (6.4 x 9.4)								
13-PDB-010-12-A															.25 x .37 (6.4 x 9.5)								
13-PDB-020-12-B															.25 x .38 (6.4 x 9.6)								
13-PDB-035-12-B	9.6 (243)	8.7 (220)	10.3 (261)	2.3 (58)	2.7 (70)	3.9 (100)	.98 (25)	3.5 (90)	M6	2.3 (58)	M4	2.9 (74)	1.9 (49)	M6	.25 x .38 (6.4 x 9.7)								
13-PDB-050-13-B																M6	.25 x .38 (6.4 x 9.8)						
13-PDB-080-13-C																M6	.25 x .39 (6.4 x 9.9)						
13-PDB-100-14-C	13.9 (354)	12.6 (320)	15.1 (384)	2.5 (66)	6.1 (155)	7.3 (185)	1.2 (30)	3.9 (100)	M8	2.4 (62)	M4	3.3 (86)	2.2 (56)	M8	.25 x .36 (6.4 x 9.10)								
13-PDB-150-14-C																							.25 x .36 (6.4 x 9.11)
13-PDB-200-14-D					7.5 (190)	8.6 (220)	1.4 (35)																2.4 (61)

Common Mode

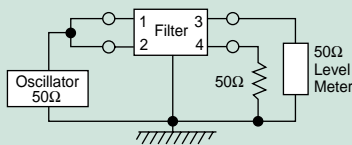

13-PDB-005;-010;-020;-035

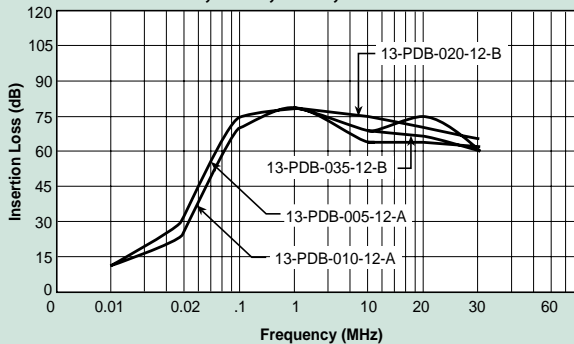

13-PDB-050;-080;-100;-150;-200

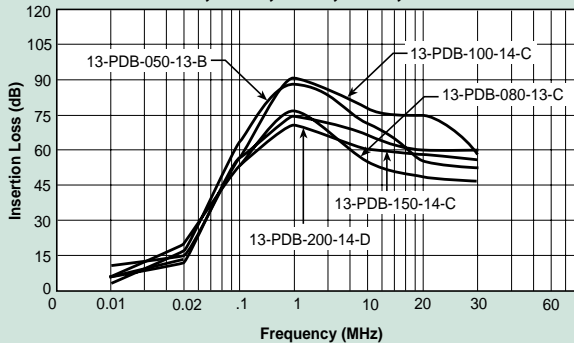

Normal Mode

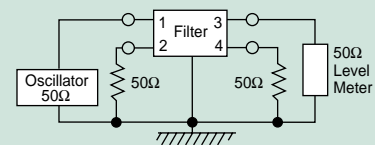

13-PDB-005;-010;-020;-035

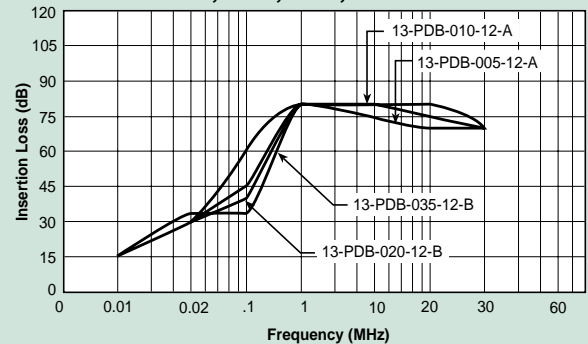

13-PDB-050;-080;-100;-150;-200

