

## 2-stage high current 3-phase filter FN 359

- 250 to 1200A current ratings
  - 440, 520 or 690VAC versions for worldwide compatibility
  - small leakage current
  - built to meet UL, CSA and EN 133200 standards
- Nennströme zwischen 250 und 1200A
  - 440/520/690VAC Versionen
  - Geringer Ableitstrom
  - Erfüllt die UL und CSA Normen sowie EN 133200
- courant de service de 250 à 1200A
  - 440, 520 ou 690Vca pour une compatibilité partout dans le monde
  - faible courant de fuite
  - fabriqué aux normes UL, CSA et EN 133200



### Technical specifications

Maximum operating voltage: standard types 440VAC; H types 520VAC; HV types 690VAC  
520VAC versions for IT-supply networks available on request

Operating frequency: DC to 60Hz at 50°C

Hipot test voltage: standard: P ⇒ E 2600VDC, P ⇒ P 1900VDC; H: P ⇒ E 2750VDC,  
P ⇒ P 2250VDC; HV: P ⇒ E 3050VDC, P ⇒ P 3000VDC; all for 2s (factory test)

MTBF at 40°C, per Mil-HB-217F: standard types 155,000 hours; H types 109,000 hours;  
HV types 128,000 hours

MTBF at 25°C, per Mil-HB-217F: standard types 307,000 hours; H types 222,000 hours;  
HV types 257,000 hours

Overload: 4 times rated current at switch on, then 1.5 times rated current for 1 minute,  
once per hour

Design corresponding to: UL 1283, CSA 22.2 No 8 1986, EN 133200

### Electrical schematic

See table for component values

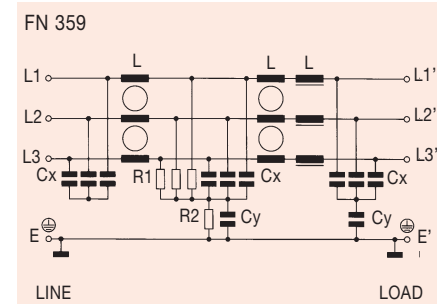

Filter	Current ratings A at 50°C	Leakage current† IEC 1000-2-4 mA at 50Hz	Power loss W	Component values/phase					Phase connections	Weight kg
				ΣL μH	ΣCx μF	ΣCy μF	R1 MΩ	R2 MΩ		
FN 359 - 250/99	250	39	25	157	11	2.3	1	0.68	busbar	16
FN 359H - 250/99	250	51	25	157	11	2.3	1	0.68	busbar	17
FN 359HV - 250/99	250	60	25	157	5.5	2.1	1.5	0.68	busbar	17
FN 359 - 300/99	300	39	35	157	11	2.3	1	0.68	busbar	16
FN 359H - 300/99	300	51	35	157	11	2.3	1	0.68	busbar	17
FN 359HV - 300/99	300	60	35	157	5.5	2.1	1.5	0.68	busbar	17
FN 359 - 400/99	400	39	43	157	11	2.3	1	0.68	busbar	18.5
FN 359H - 400/99	400	51	43	157	11	2.3	1	0.68	busbar	19.5
FN 359HV - 400/99	400	60	43	157	5.5	2.1	1.5	0.68	busbar	19.5
FN 359 - 500/99	500	39	52	165	11	2.3	1	0.68	busbar	19.5
FN 359H - 500/99	500	51	52	165	11	2.3	1	0.68	busbar	20.5
FN 359HV - 500/99	500	60	52	165	5.5	2.1	1.5	0.68	busbar	20.5
FN 359 - 600/99	600	39	65	165	11	2.3	1	0.68	busbar	20.5
FN 359H - 600/99	600	51	65	165	11	2.3	1	0.68	busbar	21.5
FN 359HV - 600/99	600	60	65	165	5.5	2.1	1.5	0.68	busbar	21.5
FN 359 - 900/99	900	39	71	63	11	2.3	1	0.68	busbar	33
FN 359H - 900/99	900	51	71	63	11	2.3	1	0.68	busbar	33.5
FN 359HV - 900/99	900	60	71	63	5.5	2.1	1.5	0.68	busbar	34.5
FN 359 - 1200/99	1200	39	104	63	11	2.3	1	0.68	busbar	35
FN 359H - 1200/99	1200	51	104	63	11	2.3	1	0.68	busbar	35.5
FN 359HV - 1200/99	1200	60	104	63	5.5	2.1	1.5	0.68	busbar	36.5

†Max. leakage under normal circumstances. Note: if two phases are interrupted, worst case leakage current could reach 5.7 times higher levels.  
Measured at: standard types 400VAC; H types 520VAC; HV types 690VAC.

## FN 359 insertion loss

Per CISPR 17; A = 50Ω/50Ω sym, B = 50Ω/50Ω asym, C = 0.1Ω/100Ω sym, D = 100Ω/0.1Ω sym

### 250A types

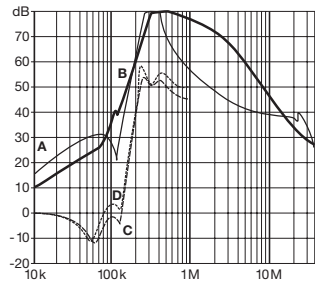

### 300A types

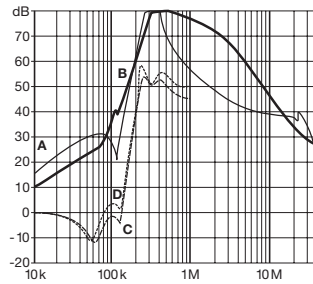

### 400A types

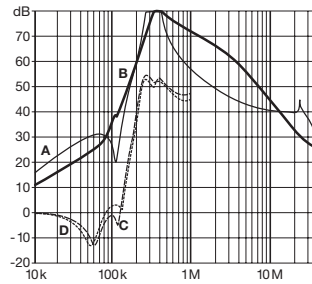

### 500A types

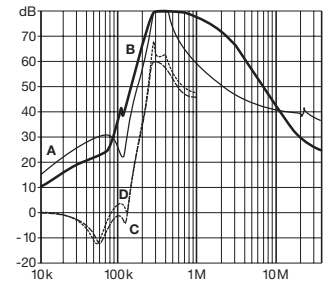

### 600A types

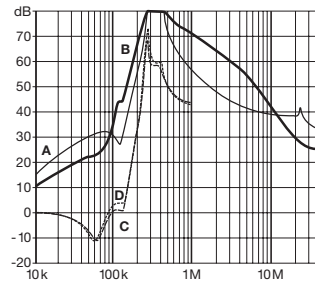

### 900A/1200A types

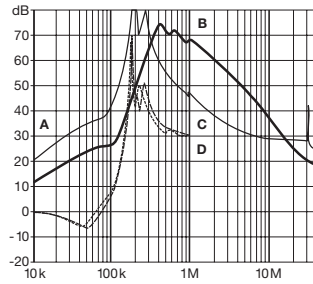

## Mechanical drawings

### SIDE VIEW

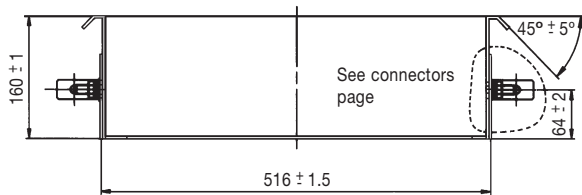

### TOP/END VIEW

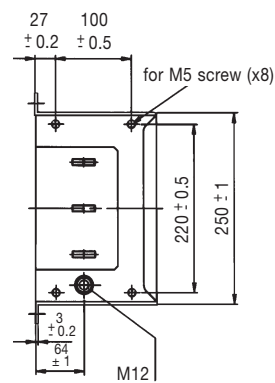
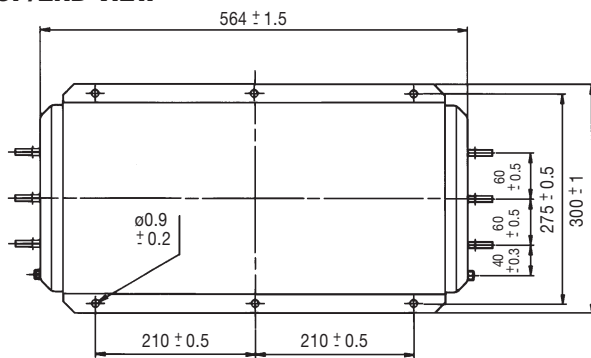

All dimensions in mm; 1 inch = 25.4 mm