

Flat Chip Capacitor/Resistor

Type CR73

1. Scope of Application

This specification applies to flat combined CR chip CR73 produced by KOA Corporation.

2. Rating

(a) Capacitor

Item	Ratings
Voltage Rating	2A: 25 VDC / 2B: 50 VDC
Temperature Coefficient	+20%/-55% (-25°C ~ +85°C)
Dissipation Factor	5% maximum (at 1 KHz 1.0 vrms)
Insulation Resistance	10,000 Mohms minimum
Dielectric Withstanding Voltage	2A: 62.5 VDC 5 sec. 50mA charge 2B: 125 VDC 5 sec. 50 mA charge

(b) Resistor

Item	Ratings
Power Rating	2A: 0.1 W / 2B: 0.125 W
Maximum Working Voltage	2A: 3V / 2B: 5 V
Maximum Overload Voltage	2A: 5V / 2B: 10 V
Temperature Coefficient	±200 ppm/C°

(c) Environment

Item	Ratings
Operation Environment	-55°C ~ 125°C
Rating Ambient Temperature	70°C

3. Type Designation

The type designation shall be the following form:

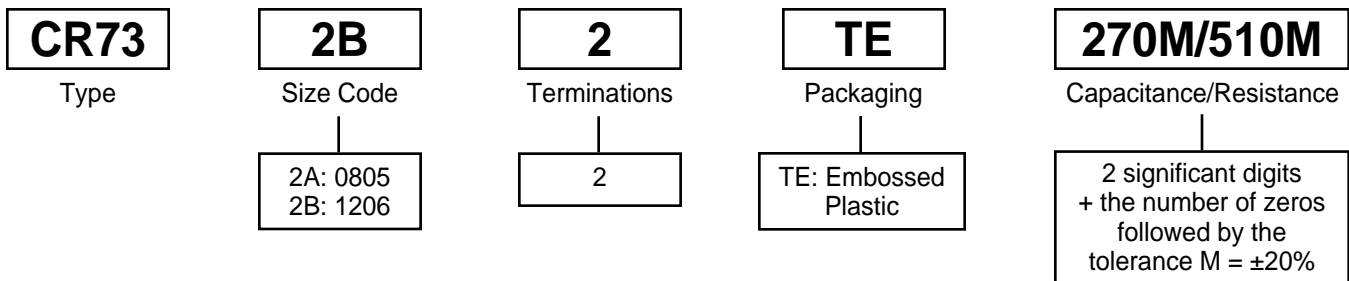

4. Capacitance Range and Resistance Range

(a) Capacitance Range

Capacitance Tolerance	Capacitance Series	Capacitance Range
2A: $\pm 20\%$	E - 6	1 pF ~ 200 pF
2B: $\pm 20\%$	E - 12	27 pF ~ 100 pF

(b) Resistance Range

Resistance Tolerance	Resistance Series	Resistance Range
2A: M ($\pm 20\%$)	E - 12	10 ohms ~ 200 ohms
2B: M ($\pm 20\%$)	E - 24	51 ohms ~ 200 ohms

5. Dimensions

5.1 2 - Terminals

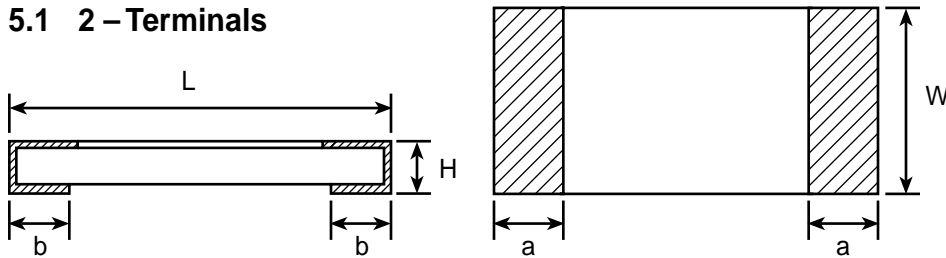

(unit: mm)

	Dimensions				
	L	W	H	a	b
2A	2.0 ± 0.2	1.25 ± 0.2	0.7 ± 0.1	0.4 ± 0.3	$0.3 \pm \begin{smallmatrix} 0.2 \\ 0.1 \end{smallmatrix}$
2B	3.2 ± 0.2	1.6 ± 0.2	0.7 ± 0.1	0.5 ± 0.3	$0.4 \pm \begin{smallmatrix} 0.2 \\ 0.1 \end{smallmatrix}$

5.2 Circuit Schematic

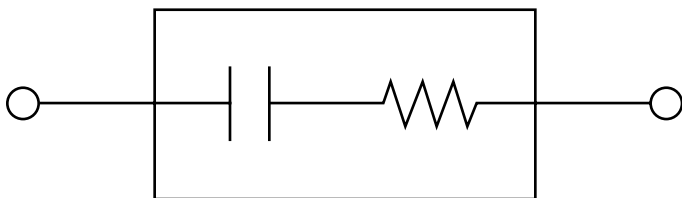

6. Structure

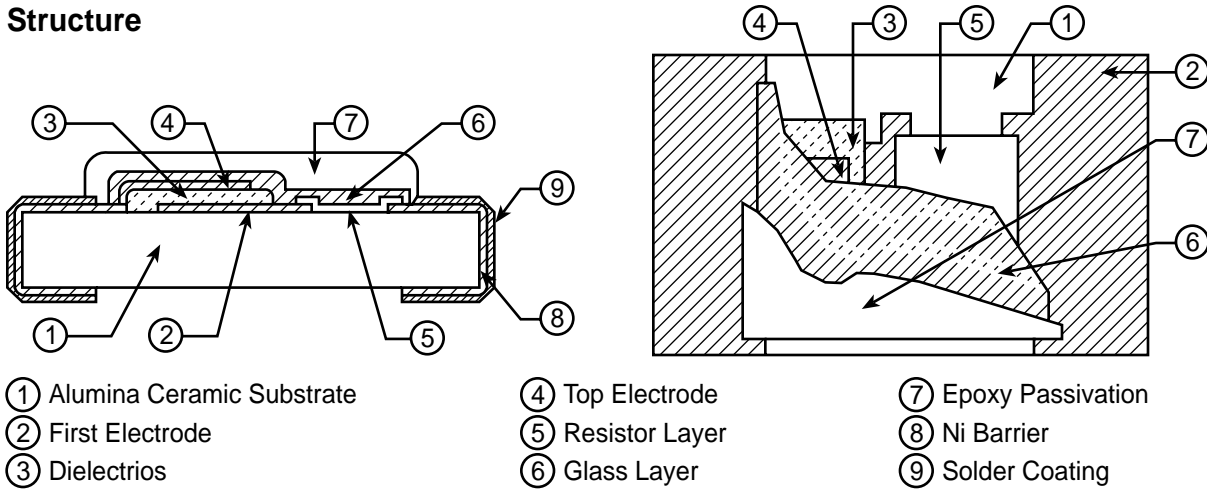

7. Outer Coating Color

Outer Coating Color (Capacitor Side) — Dark blue
 Outer Coating Color (Resistor Side) — Yellow

8. Test Conditions

Unless otherwise specified, the test shall be performed in accordance with JIS-C-5020 specifying at the temperature of $20 \pm 15^\circ\text{C}$ and at the humidity of $65 \pm 20\%$.

If questions arise about the test results, the test shall be performed at the temperature of $20 \pm 2^\circ\text{C}$ and at the humidity of $65 \pm 5\%$.

9. Reliability Test

9.1 Electrical Characteristics

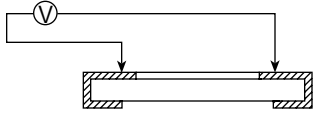
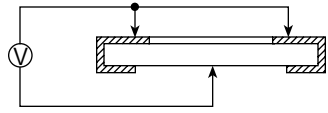
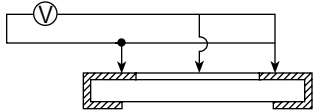
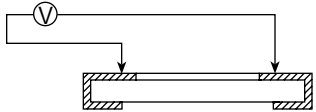
Item	Requirement	Test Methods
Insulation Resistance	More than 10^4 M Ω	Within 2 minutes at 50 VDC between terminal and another 
	More than 10^4 M Ω	1 minute at 500 VDC between both terminals and reverse side 
	More than 10^3 M Ω	1 minute at 500 VDC between both terminals and coating 
Dielectric Withstanding Voltage	No evidence of fuming, flaming or breakdown	2.5 times maximum rated voltage for 5 seconds with 50 mA maximum charging current 
Noise (Resistor)	More less 15dB	Per MIL-STD-202, Method 308

9.2 Mechanical Characteristics

Item	Requirement	Test Methods
Resistance to Soldering Heat	No evidence of damage ΔC within $\pm 10\%$ ΔR within $\pm 3\%$	Immerse in the solder (H63A) of $260^{\circ}\text{C} \pm 5^{\circ}\text{C}$ for 10 ± 1 sec
Solderability	Approximately 95% of the terminal should be covered with new solder	Immerse in the solder (H63A) of $230^{\circ}\text{C} \pm 5^{\circ}\text{C}$ for 3 ± 0.5 sec
Terminal Strength (Bend test)	No mechanical damage	Specimen shall be soldered on PCB and support by applying strength so that the bending width becomes 3mm
Terminal Strength (Pull test)	200g minimum	Per MIL-R-55342 4.7.12.2
Vibration	No evidence of damage ΔC within $\pm 10\%$ ΔR within $\pm 3\%$	2 hours in each direction of X,Y,Z on PCB at a frequency range of 10-55-10Hz with 1.5mm amplitude

9.3 Environmental Characteristics

Item	Requirement	Test Methods
Temperature cycling	No evidence of damage ΔC within $\pm 10\%$ ΔR within $\pm 3\%$	100 cycles between $-40^{\circ}\text{C}/30$ minutes and $+125^{\circ}\text{C}/30$ minutes
Humidity (No Load)	No evidence of damage ΔC within $\pm 10\%$ ΔR within $\pm 3\%$	Per MIL-STD-202F Method 106 10 cycles
Moisture Resistance	No evidence of damage ΔC within $\pm 10\%$ ΔR within $\pm 3\%$	Temp. $40^{\circ}\text{C} \pm 2^{\circ}\text{C}$ Humidity 90% ~ 95% 1000 hours DC 50V 1.5 hours ON 0.5 hours OFF
Load Life	No evidence of damage ΔC within $\pm 10\%$ ΔR within $\pm 3\%$	Temp. $70^{\circ}\text{C} \pm 2^{\circ}\text{C}$ 1000 hours DC 50V 1.5 hours ON 0.5 hours OFF

10. Packaging

10.1 Bulk Packaging

200 pieces chip are packed in a poly bag.
The marking seal shall be marked:

- (1) Type designation
- (2) Nominal Capacitance/Nominal Resistance
- (3) Quantity
- (4) Production Lot. No.
- (5) Manufacturer's name

10.2 Taping

The taping shall be embossed carrier tapes
of 8 mm width and 4 mm pitches.
The standard quantity per reel shall be 4000 pieces.

(1) Dimensions of Carrier Tape

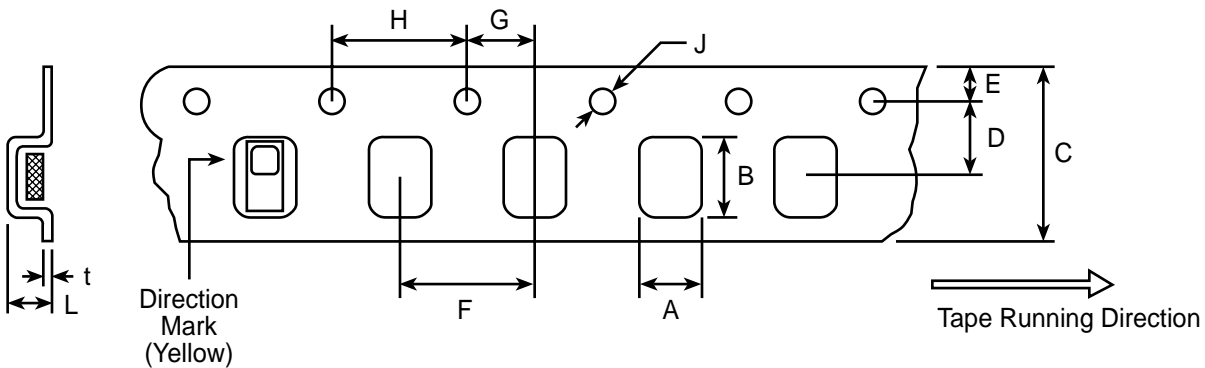

(unit: mm)

Type	A	B	C	D	E
CR73 2A	1.6 ± 0.2	2.4 ± 0.2	8.0 ± 0.2	3.5 ± 0.05	1.75 ± 0.1
CR73 2B	1.9 ± 0.2	3.5 ± 0.2	8.0 ± 0.2	3.5 ± 0.05	1.75 ± 0.1

F	G	H	J	L	t
2A: 4.0 ± 0.1	2.0 ± 0.1	4.0 ± 0.1	1.5 ± 0.1	1.0 ± 0.15	0.25 ± 0.1
2B: 4.0 ± 0.1	2.0 ± 0.1	4.0 ± 0.1	1.5 ± 0.1	0.85 ± 0.1	0.25 ± 0.1

Top tape peeling strength: 10 ~ 50g

(2) Reel Dimensions and Marking

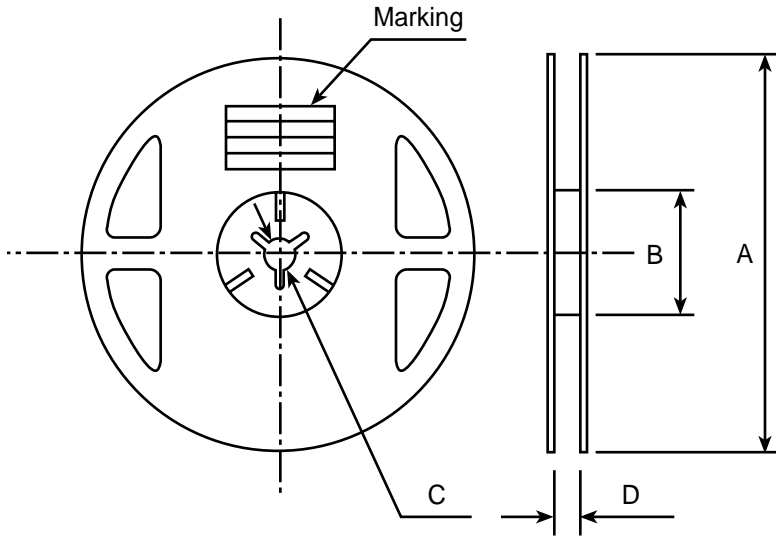

Contents on label

- (1) Article No.
- (2) Quantity
- (3) Nominal capacitance/
Nominal resistance
- (4) Customer's code No.
(Subject to change)
- (5) Production lot No.
- (6) Manufacturer's name

(unit: mm)

Type	Tape		A	B	C	D
2A / 2B	Embossed Carrier	TE	178 ± 2	60 ± 2	13 ± 0.5	10 ± 1.5

Quan./Reel (pieces)	Reel Material
4,000	Plastic

11. Pattern Design

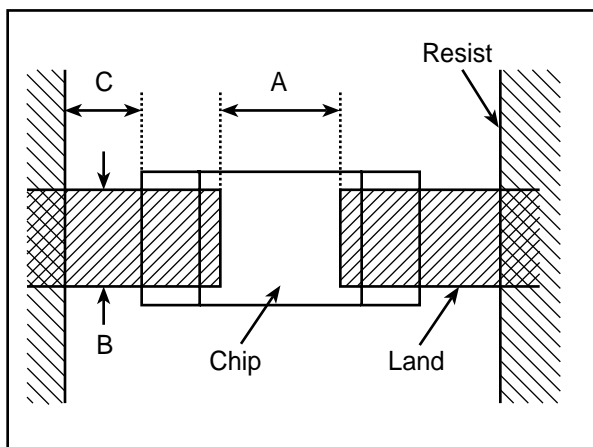

(unit: mm)

Type	A	B	C
2A	1.3	1.05	0.4 ~ 0.8
2B	2.0 ~ 2.4	1.2 ~ 1.6	0.4 ~ 0.8

12. Soldering

Reflow soldering should be done at 240°C for less than 20 seconds.

Flow soldering should be done at 260°C for less than 10 seconds.

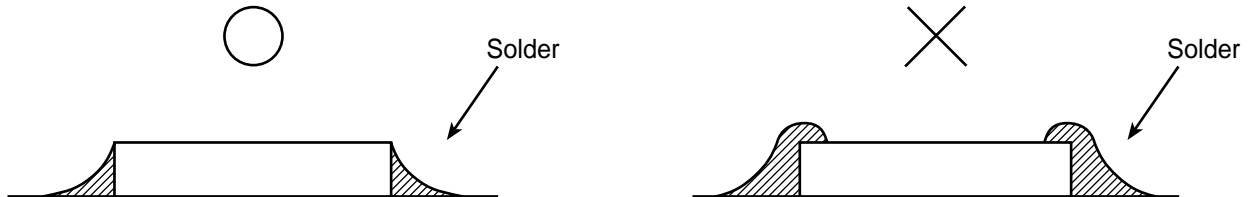

13. Measurement Method

(1) Measurement Method of C and R

An impedance element connected with a resistor and a capacitor in series shall be considered as a series equivalent circuit element and a C value and R value shall be measured in $f = 100\text{MHz}$ with the series equivalent circuit.

(2) Measurement Method of D. F.

DISSIPATION FACTOR shall be measured in $f = 1\text{KHz}$ as the impedance element connected in series with the resistor and the capacitor.

(3) Tolerance

a) CAPACITANCE TOLERANCE

The capacitance tolerance is regulated to measure Z (impedance) in $f = 1\text{MHz}$ and to compare the C value with a nominal capacitance tolerance at this time.

b) RESISTANCE TOLERANCE

The resistance tolerance is regulated to measure Z (impedance) in $f = 100\text{MHz}$ and to seek the resistance with the C value and to compare it with the nominal resistance.