

Multilayer Ceramic Chip Capacitor

Type TYC Series

Type TYC Series



Multilayer ceramic capacitors (MLCC) are manufactured by suspending ceramic powders in liquid and casting into a thin green sheet from 20mm in thickness to 5mm or thinner.

Metal electrodes are sieved printed onto green sheets, which are later stacked to form a laminated structure. The metal electrodes are arranged so that the termination alternates from one edge to another of the capacitor.

Upon sintering at high temperature the part becomes a monolithic block, which can provide an extremely high capacitance in small mechanical volumes.

Finally, the termination electrodes are formed by composite of outer metal-glass electrode and followed by a barrier layer and pure-tin plating to permit MLCC to be soldered directly onto printed circuit board.

Key Features

- Choice of Dielectrics (NPO, X7R, X5R, Y5V)
- 0402 to 1812 sizes as standard
- Other sizes available. 0201 available soon
- 6.3V to 50V in standard range
- Voltage ratings to 3kV on selected products
- Range of tolerances available
- RoHS Compliant
- Excellent thermal stability
- Low dissipation factor

Structure

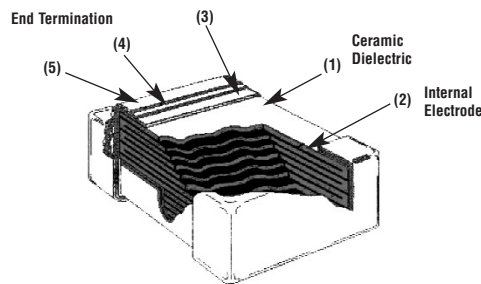

Class 1

No	Specifications	Material
1	Ceramic dielectric	Barium titanate base
2	Internal Electrode	Pb, PdAg
3	Inner Layer	Ag
4	End Terminal Middle Layer	Ni
5	End Terminal Outer Layer	Sn

Class 2

No	Specifications	Material
1	Ceramic dielectric	Barium titanate base
2	Internal Electrode	Pb, PbAg Ni
3	Inner Layer	Ag Cu
4	End Terminal Middle Layer	Ni
5	End Terminal Outer Layer	Sn

Dimensions

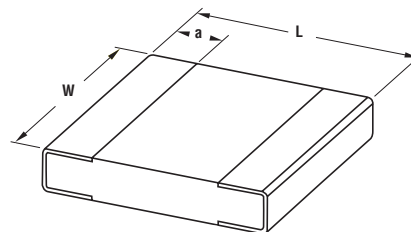

SIZE CODE	L	W	A
0402	1.00±0.05	0.50±0.05	0.25+0.05/-0.10
0603	1.60±0.10	0.80±0.07	0.40±0.15
0805	2.00±0.15	1.25±0.10	0.50±0.20
1206	3.20±0.15	1.60±0.15	0.60±0.20
1210	3.20±0.30	2.50±0.20	0.75±0.25
1808	4.50±0.40	2.03±0.25	0.75±0.25
1812	4.50±0.40	3.20±0.30	0.75±0.25

Capacitance & Voltage (NPO)

EIA Code	Size	0402				0603				0805				1206				1210				1812				
	VDCW	10V	16V	25V	50V	10V	16V	25V	50V	10V	16V	25V	50V	10V	16V	25V	50V	10V	16V	25V	50V	10V	16V	25V	50V	
0R5	0.5pF	N	N	N	N	S	S	S	S	A	A	A	A													
1R0	1	N	N	N	N	S	S	S	S	A	A	A	A													
1R2	1.2	N	N	N	N	S	S	S	S	A	A	A	A													
1R5	1.5	N	N	N	N	S	S	S	S	A	A	A	A	B	B	B	B									
1R8	1.8	N	N	N	N	S	S	S	S	A	A	A	A	B	B	B	B									
2R2	2.2	N	N	N	N	S	S	S	S	A	A	A	A	B	B	B	B									
2R7	2.7	N	N	N	N	S	S	S	S	A	A	A	A	B	B	B	B									
3R3	3.3	N	N	N	N	S	S	S	S	A	A	A	A	B	B	B	B									
3R9	3.9	N	N	N	N	S	S	S	S	A	A	A	A	B	B	B	B									
4R7	4.7	N	N	N	N	S	S	S	S	A	A	A	A	B	B	B	B									
5R6	5.6	N	N	N	N	S	S	S	S	A	A	A	A	B	B	B	B									
6R8	6.8	N	N	N	N	S	S	S	S	A	A	A	A	B	B	B	B									
8R2	8.2	N	N	N	N	S	S	S	S	A	A	A	A	B	B	B	B									
100	10pF	N	N	N	N	S	S	S	S	A	A	A	A	B	B	B	B									
120	12	N	N	N	N	S	S	S	S	A	A	A	A	B	B	B	B									
150	15	N	N	N	N	S	S	S	S	A	A	A	A	B	B	B	B									
180	18	N	N	N	N	S	S	S	S	A	A	A	A	B	B	B	B									
220	22	N	N	N	N	S	S	S	S	A	A	A	A	B	B	B	B	C	C	C	C					
270	27	N	N	N	N	S	S	S	S	A	A	A	A	B	B	B	B	C	C	C	C					
330	33	N	N	N	N	S	S	S	S	A	A	A	A	B	B	B	B	C	C	C	C					
390	39	N	N	N	N	S	S	S	S	A	A	A	A	B	B	B	B	C	C	C	C					
470	47	N	N	N	N	S	S	S	S	A	A	A	A	B	B	B	B	C	C	C	C					
560	56	N	N	N	N	S	S	S	S	A	A	A	A	B	B	B	B	C	C	C	C					
680	68	N	N	N	N	S	S	S	S	A	A	A	A	B	B	B	B	C	C	C	C					
820	82	N	N	N	N	S	S	S	S	A	A	A	A	B	B	B	B	C	C	C	C					
101	100pF	F	N	N	N	N	S	S	S	A	A	A	A	B	B	B	B	C	C	C	C					
121	120	N	N	N	N	S	S	S	S	A	A	A	A	B	B	B	B	C	C	C	C					
151	150	N	N	N	N	S	S	S	S	A	A	A	A	B	B	B	B	C	C	C	C					
181	180	N	N	N	N	S	S	S	S	A	A	A	A	B	B	B	B	C	C	C	C					
221	220	N	N	N	N	S	S	S	S	A	A	A	A	B	B	B	B	C	C	C	C					
271	270	N	N	N	N	S	S	S	S	A	A	A	A	B	B	B	B	C	C	C	C					
331	330	N	N	N	N	S	S	S	S	A	A	A	A	B	B	B	B	C	C	C	C					
391	390	N	N			S	S	S	S	B	B	B	B	B	B	B	B	C	C	C	C					
471	470	N	N			S	S	S	S	B	B	B	B	B	B	B	B	C	C	C	C					
561	560					S	S	S	S	B	B	B	B	B	B	B	B	C	C	C	C					
681	680					S	S	S	S	B	B	B	B	B	B	B	B	C	C	C	C					
821	820					S	S	S	S	B	B	B	B	B	B	B	B	C	C	C	C					
102	1000pF					S	S	S	S	B	B	B	B	B	B	B	B	C	C	C	C	D	D	D	D	D
122	1200					S	S	S	S	B	B	B	B	B	B	B	B	C	C	C	C	D	D	D	D	D
152	1500					S	S	S	S	B	B	B	B	B	B	B	B	C	C	C	C	D	D	D	D	D
182	1800					S	S	S	S	B	B	B	B	B	B	B	B	C	C	C	C	D	D	D	D	D
222	2200					S	S	S	S	B	B	B	B	B	B	B	B	C	C	C	C	D	D	D	D	D
272	2700					S	S	D	D	D	D			B	B	B	B	C	C	C	C	D	D	D	D	D
332	3300					S	S	D	D	D	D			B	B	B	B	C	C	C	C	D	D	D	D	D
392	3900									D	D	D	D	B	B	B	B	C	C	C	C	D	D	D	D	D
472	4700									D	D	D	D	B	B	B	B	C	C	C	C	D	D	D	D	D
562	5600									D	D			B	B	B	B	C	C	C	C	D	D	D	D	D
682	6800									D	D			C	C	C	C					D	D	D	D	D
822	8200									D	D			C	C	C	C					D	D	D	D	D
103	0.01µF									D	D		D'									D	D	D	D	D
123	0.012																					D	D	D	D	D
153	0.015																					D	D	D	D	D
183	0.018																					D	D	D	D	D
223	0.022																					D	D	D	D	D
273	0.027																					D	D	D	D	D
333	0.033																					D	D	D	D	D
393	0.039																					D	D	D	D	D
473	0.047																					D	D	D	D	D
563	0.056																					D	D	D	D	D
683	0.068																					D	D	D	D	D
823	0.082																					D	D	D	D	D
104	0.1µF									D	D											D	D	D	D	D

(1) [D']: The thickness spec. of said items is special defined on 1.25±0.2mm for 0805 and 1.15±0.15mm for 1206.

Size Unit: Inch (mm)	0402 (1005)	0603 (1608)	0805 (2012)	1206 (3216)	1210 (3225)	1808 (4520)	1812 (4532)
A= 0.60±0.10 mm	-	-	Paper 4Kp/reel	-	-	-	-
B= 0.80±0.10 mm	-	-	Paper 4Kp/reel	Paper 4Kp/reel	-	-	-
C= 0.95±0.10 mm	-	-	-	Plastic 3Kp/reel	Plastic 3Kp/reel	-	-
D= 1.25±0.10 mm	-	-	Plastic 3Kp/reel	Plastic 3Kp/reel	Plastic 3Kp/reel	Plastic 2Kp/reel	Plastic 1Kp/reel
G= 1.60±0.20 mm	-	-	-	Plastic 2Kp/reel	Plastic 2Kp/reel	-	-
S= 0.80±0.07 mm	-	Paper 4Kp/reel	-	-	-	-	-
N= 0.50±0.05 mm	Paper 10Kp/reel	-	-	-	-	-	-
K= 2.00±0.20 mm	-	-	-	-	Plastic 2Kp/reel	Plastic 1Kp/reel	Plastic 1Kp/reel
M= 2.50±0.30 mm	-	-	-	-	Plastic 1Kp/reel	-	Plastic 1Kp/reel

Capacitance & Voltage (Hi-Voltage NPO)

EIA Code	Size	0603	0805				1206				1210				1808			1812									
	VDCW	100	100	200	250	500	100	200	250	500	1000	2000	100	200	250	500	1000	2000	3000	100	200	250	500	1000	2000	3000	
0R5	0.5pF	S	A	A	A	A																					
1R0	1	S	A	A	A	A																					
1R2	1.2	S	A	A	A	A																					
1R5	1.5	S	A	A	A	A	B	B	B	B	B	B															
1R8	1.8	S	A	A	A	A	B	B	B	B	B	B															
2R2	2.2	S	A	A	A	A	B	B	B	B	B	B															
2R7	2.7	S	A	A	A	A	B	B	B	B	B	B															
3R3	3.3	S	A	A	A	A	B	B	B	B	B	B															
3R9	3.9	S	A	A	A	A	B	B	B	B	B	B															
4R7	4.7	S	A	A	A	A	B	B	B	B	B	B															
5R6	5.6	S	A	A	A	A	B	B	B	B	B	B															
6R8	6.8	S	A	A	A	A	B	B	B	B	B	B															
8R2	8.2	S	A	A	A	A	B	B	B	B	B	B															
100	10pF	S	A	A	A	A	B	B	B	B	B	B	C	C	C	C	C	C	D	D	D	D	D	D	D	D	D
120	12	S	A	A	A	A	B	B	B	B	B	B	C	C	C	C	C	C	D	D	D	D	D	D	D	D	D
150	15	S	A	A	A	A	B	B	B	B	B	B	C	C	C	C	C	C	D	D	D	D	D	D	D	D	D
180	18	S	A	A	A	A	B	B	B	B	B	B	C	C	C	C	C	C	D	D	D	D	D	D	D	D	D
220	22	S	A	A	A	A	B	B	B	B	B	B	C	C	C	C	C	C	D	D	D	D	D	D	D	D	D
270	27	S	A	A	A	A	B	B	B	B	B	B	C	C	C	C	C	C	D	D	D	D	D	D	D	D	D
330	33	S	A	A	A	A	B	B	B	B	B	B	C	C	C	C	C	C	D	D	D	D	D	D	D	D	D
390	39	S	A	A	A	A	B	B	B	B	B	B	C	C	C	C	C	C	D	D	D	D	D	D	D	D	D
470	47	S	A	A	A	A	B	B	B	B	B	B	C	C	C	C	C	C	D	D	D	D	D	D	D	D	D
560	56	S	A	A	A	A	B	B	B	B	B	B	C	C	C	C	C	C	D	D	D	D	D	D	D	D	D
680	68	S	A	A	A	A	B	B	B	B	B	B	C	C	C	C	C	C	D	D	D	D	D	D	D	D	D
820	82	S	A	A	A	B	B	B	B	B	B	B	C	C	C	C	C	C	D	D	D	D	D	D	D	D	D
101	100pF	S	A	A	A	B	B	B	B	B	B	B	C	C	C	C	C	C	D	D	D	D	D	D	D	D	D
121	120	S	A	A	A	D	B	B	B	B	B	B	D	C	C	C	C	C	D	D	D	D	D	D	D	D	D
151	150	S	A	B	B	D	B	B	B	B	C	D	C	C	C	C	C	C	D	D	D	D	D	D	D	D	D
181	180	S	A	B	B	D	B	B	B	B	C	G	C	C	C	C	C	C	D	D	D	K	D	D	D	D	D
221	220	S	A	D	D	D	B	B	B	B	D	G	C	C	C	C	C	C	D	D	D	K	D	D	D	D	D
271	270	S	A	D	D	D	B	B	B	C	D		C	C	C	C	C	D	D	D	K	D	D	D	D	D	K
331	330	S	A	D	D	D	B	B	B	C			C	C	C	C	D		D	D		D	D	D	D	D	K
391	390	S	B	D	D	D	B	B	B	C			C	C	C	C	D		D	K		D	D	D	D	D	K
471	470	S	B	D	B	C	C	C	C				C	C	C	C	D		D	K		D	D	D	D	D	K
561	560	S	B	D	B	C	C	C					C	C	C	C			K	K		D	D	D	D	D	D
681	680	B	D	B	C	C	C						C	C	C	C			K	K		D	D	D	D	D	K
821	820	B	D	B	C	D	D						C	C	C	C			K	K		D	D	D	D	D	K
102	1000pF	B	B		C								C	C	C	C			K			D	D	D	D	K	K
122	1200	B	B	C									C	D	D	D						D	D	D	D	K	
152	1500	B	B	C									C	D	D	D						D	D	D	D	K	
182	1800	B	B	C									C	D	D	D						D	D	D	D		
222	2200	B	B	D									C	D	D							D	D	D	D		
272	2700	D	B										C	D	D							D	D	D	D		
332	3300	D	B										C	D								D	D	D	D		
392	3900	D	B										C	D								D	D				
472	4700	B											C									D	D				
562	5600	B											C									D	D				
682	6800	C											C									D	D				
822	8200	C											C									D					
103	0.01µF												C									D					
123	0.012												D									D					
153	0.015												D									D					
183	0.018												D									D					
223	0.022												D									D					
273	0.027												D									D					
333	0.033µF												D									D					

Size Unit: Inch (mm)	0402 (1005)	0603 (1608)	0805 (2012)	1206 (3216)	1210 (3225)	1808 (4520)	1812 (4532)
A= 0.60±0.10 mm	-	-	Paper 4Kp/reel	-	-	-	-
B= 0.80±0.10 mm	-	-	Paper 4Kp/reel	Paper 4Kp/reel	-	-	-
C= 0.95±0.10 mm	-	-	-	Plastic 3Kp/reel	Plastic 3Kp/reel	-	-
D= 1.25±0.10 mm	-	-	Plastic 3Kp/reel	Plastic 3Kp/reel	Plastic 3Kp/reel	Plastic 2Kp/reel	Plastic 1Kp/reel
G= 1.60±0.20 mm	-	-	-	Plastic 2Kp/reel	Plastic 2Kp/reel	-	-
S= 0.80±0.07 mm	-	Paper 4Kp/reel	-	-	-	-	-
N= 0.50±0.05 mm	Paper 10Kp/reel	-	-	-	-	-	-
K= 2.00±0.20 mm	-	-	-	-	Plastic 2Kp/reel	Plastic 1Kp/reel	Plastic 1Kp/reel
M= 2.50±0.30 mm	-	-	-	-	Plastic 1Kp/reel	-	Plastic 1Kp/reel

Capacitance & Voltage (X7R/X5R)

EIA Code	Size	0402				0603				0805				1206				1210				1812								
	VDCW	10V	16V	25V	50V	6.3V	10V	16V	25V	50V	6.3V	10V	16V	25V	50V	6.3V	10V	16V	25V	50V	6.3V	10V	16V	25V	50V	6.3V	10V	16V	25V	50V
101	100pF	N	N	N	N	S	S	S	S	S	B	B	B	B																
121	120	N	N	N	N	S	S	S	S	S	B	B	B	B																
151	150	N	N	N	N	S	S	S	S	S	B	B	B	B																
181	180	N	N	N	N	S	S	S	S	S	B	B	B	B	B [^]	B [^]	B [^]	B [^]												
221	220	N	N	N	N	S	S	S	S	S	B	B	B	B	B [^]	B [^]	B [^]	B [^]												
271	270	N	N	N	N	S	S	S	S	S	B	B	B	B	B [^]	B [^]	B [^]	B [^]												
331	330	N	N	N	N	S	S	S	S	S	B	B	B	B	B [^]	B [^]	B [^]	B [^]												
391	390	N	N	N	N	S	S	S	S	S	B	B	B	B	B [^]	B [^]	B [^]	B [^]												
471	470	N	N	N	N	S	S	S	S	S	B	B	B	B	B [^]	B [^]	B [^]	B [^]												
561	560	N	N	N	N	S	S	S	S	S	B	B	B	B	B [^]	B [^]	B [^]	B [^]												
681	680	N	N	N	N	S	S	S	S	S	B	B	B	B	B [^]	B [^]	B [^]	B [^]												
821	820	N	N	N	N	S	S	S	S	S	B	B	B	B	B	B	B	B												
102	1000pF	N	N	N	N	S	S	S	S	S	B	B	B	B	B	B	B	B	C [^]	C [^]	C [^]	C [^]		D [^]	D [^]	D [^]	D [^]			
122	1200	N	N	N	N	S	S	S	S	S	B	B	B	B	B	B	B	B	C [^]	C [^]	C [^]	C [^]		D [^]	D [^]	D [^]	D [^]			
152	1500	N	N	N	N	S	S	S	S	S	B	B	B	B	B	B	B	B	C [^]	C [^]	C [^]	C [^]		D [^]	D [^]	D [^]	D [^]			
182	1800	N	N	N	N	S	S	S	S	S	B	B	B	B	B	B	B	B	C [^]	C [^]	C [^]	C [^]		D [^]	D [^]	D [^]	D [^]			
222	2200	N	N	N	N	S	S	S	S	S	B	B	B	B	B	B	B	B	C [^]	C [^]	C [^]	C [^]		D [^]	D [^]	D [^]	D [^]			
272	2700	N	N	N	N	S	S	S	S	S	B	B	B	B	B	B	B	B	C [^]	C [^]	C [^]	C [^]		D [^]	D [^]	D [^]	D [^]			
332	3300	N	N	N	N	S	S	S	S	S	B	B	B	B	B	B	B	B	C [^]	C [^]	C [^]	C [^]		D [^]	D [^]	D [^]	D [^]			
392	3900	N	N	N	N	S	S	S	S	S	B	B	B	B	B	B	B	B	C [^]	C [^]	C [^]	C [^]		D [^]	D [^]	D [^]	D [^]			
472	4700	N	N	N	N	S	S	S	S	S	B	B	B	B	B	B	B	B	C [^]	C [^]	C [^]	C [^]		D [^]	D [^]	D [^]	D [^]			
562	5600	N	N	N	N	S	S	S	S	S	B	B	B	B	B	B	B	B	C [^]	C [^]	C [^]	C [^]		D [^]	D [^]	D [^]	D [^]			
682	6800	N	N	N	N	S	S	S	S	S	B	B	B	B	B	B	B	B	C [^]	C [^]	C [^]	C [^]		D [^]	D [^]	D [^]	D [^]			
822	8200	N	N	N	N	S	S	S	S	S	B	B	B	B	B	B	B	B	C	C	C	C		D [^]	D [^]	D [^]	D [^]			
103	0.01µF	N	N	N	N	S	S	S	S	S	B	B	B	B	B	B	B	B	C	C	C	C		D [^]	D [^]	D [^]	D [^]			
123	0.012	N	N	N	N	S	S	S	S	S	B	B	B	B	B	B	B	B	C	C	C	C		D [^]	D [^]	D [^]	D [^]			
153	0.015	N	N	N	N	S	S	S	S	S	B	B	B	B	B	B	B	B	C	C	C	C		D [^]	D [^]	D [^]	D [^]			
183	0.018	N	N	N	N	S	S	S	S	S	B	B	B	B	B	B	B	B	C	C	C	C		D [^]	D [^]	D [^]	D [^]			
223	0.022	N	N	N	N	S	S	S	S	S	B	B	B	B	B	B	B	B	C	C	C	C		D [^]	D [^]	D [^]	D [^]			
273	0.027	N	N	N	N	S	S	S	S	S	B	B	B	B	B	B	B	B	C	C	C	C		D [^]	D [^]	D [^]	D [^]			
333	0.033	N	N	N	N	S	S	S	S	S	B	B	B	B	B	B	B	B	C	C	C	C		D [^]	D [^]	D [^]	D [^]			
393	0.039	N	N	N	N	S	S	S	S	S	B	B	B	B	B	B	B	B	C	C	C	C		D [^]	D [^]	D [^]	D [^]			
473	0.047	N	N	N	N	S	S	S	S	S	B	B	B	B	B	B	B	B	C	C	C	C		D [^]	D [^]	D [^]	D [^]			
563	0.056	N	N	N	N	S	S	S	S	S	B	B	B	B	B	B	B	B	C	C	C	C		D [^]	D [^]	D [^]	D [^]			
683	0.068	*N	N	N	N	S	S	S	S	S	B	B	B	B	B	B	B	B	C	C	C	C		D [^]	D [^]	D [^]	D [^]			
823	0.082	*N	N	N	N	S	S	S	S	S	B	B	B	D	B	B	B	B	C	C	C	C		D	D	D	D			
104	0.1µF	*N	N	N	N	S	S	S	S	S	B	B	B	D	B	B	B	B	C	C	C	C		D	D	D	D			
124	0.12	N	N	N	N	S	S	S	S	S	B	B	B	D	B	B	B	B	C	C	C	C		D	D	D	D			
154	0.15	N	N	N	N	S	S	S	S	S	D	D	D	D	C	C	C	C	C	C	C	C		D	D	D	D			
184	0.18	N	N	N	N	S	S	S	S	S	D	D	D	D'	C	C	C	C	C	C	C	C		D	D	D	D			
224	0.22	N	N	N	N	S	S	S	S	S	D	D	D	D'	C	C	C	C	C	C	C	C		D	D	D	D			
274	0.27	N	N	N	N	S	S	S	S	S	D	D	D	D	C	C	C	C	C	C	C	C		D	D	D	D			
334	0.33	N	N	N	N	*S'	S	S	S	S	D	D	D	D	C	C	C	C	C	C	C	C		D	D	D	D			
394	0.39	N	N	N	N	S	S	S	S	S	D	D	D	D	C	C	C	C	C	C	C	C		D	D	D	D			
474	0.47	N	N	N	N	*S'	S	S	S	S	D	D	D'	D	D	D'	G'	G'	C	C	C	C		D	D	D	D			
564	0.56	N	N	N	N	S	S	S	S	S	D	D	D	D	D	D	D	D						D	D	D	D			
684	0.68	N	N	N	N	S	S	S	S	S	D	D'	D	D	D	D	D	D						D	D	D	D			
824	0.82	N	N	N	N	S	S	S	S	S	D	D	D	D	D	D	D	D						D	D	D	D			
105	1µF	N	N	N	N	*S'	*S'	S	S	S	D	D'	D'	D	D	D	G'	G'	G	G	G	G		D	D	D	D			
225	2.2	N	N	N	N	*S'	S	S	S	S	*D'	*D'	D	D	*D'	*D'	G'	G'	K	K	K	K								
335	3.3	N	N	N	N	S	S	S	S	S	*D'	*D'	D	D	*G'	*G'	G'	G'	K	K	K	K								
475	4.7	N	N	N	N	S	S	S	S	S	*D'	D	D	D	*G'	*G'	*G'	G'	K	K	K	K								
685	6.8	N	N	N	N	S	S	S	S	S	S	S	S	S	S	S	S	S												
106	10µF	N	N	N	N	S	S	S	S	S	*D'	D	D	D	*G'	*G'	G'	G'	*K	*K	*K	K					M			
226	22µF	N	N	N	N	S	S	S	S	S	S	S	S	S	*G'	*G'	G'	G'	*M	*M	*M	M					*M			
107	100µF	N	N	N	N	S	S	S	S	S	S	S	S	S	S	S	S	S												

(1) [^]: The said items are made by NME (Noble Metal Electrode).
 (2) [*]: The said items are available in X5R.
 (3) [S']: The thickness spec. of said items is special defined on 0.80±0.15/-0.1mm.
 (4) [D']: The thickness spec. of said items is special defined on 1.25±0.2mm for 0805 and 1.15±0.15mm for 1206.
 (5) [G']: The thickness spec. of said items is special defined on 1.60±0.3/-0.1mm.

Size Unit: Inch (mm)	0402 (1005)	0603 (1608)	0805 (2012)	1206 (3216)	1210 (3225)	1808 (4520)	1812 (4532)
A= 0.60±0.10 mm	-	-	Paper 4Kp/reel	-	-	-	-
B= 0.80±0.10 mm	-	-	Paper 4Kp/reel	-	-	-	-
C= 0.95±0.10 mm	-	-	-	Plastic 3Kp/reel	Plastic 3Kp/reel	-	-
D= 1.25±0.10 mm	-	-	Plastic 3Kp/reel	Plastic 3Kp/reel	Plastic 3Kp/reel	Plastic 2Kp/reel	Plastic 1Kp/reel
G= 1.60±0.20 mm	-	-	-	Plastic 2Kp/reel	Plastic 2Kp/reel	-	-
S= 0.80±0.07 mm	-	Paper 4Kp/reel	-	-	-	-	-
N= 0.50±0.05 mm	Paper 10Kp/reel	-	-	-	-	-	-
K= 2.00±0.20 mm	-	-	-	-	Plastic 2Kp/reel	Plastic 1Kp/reel	Plastic 1Kp/reel
M= 2.50±0.30 mm	-	-	-	-	Plastic 1Kp/reel	-	Plastic 1Kp/reel
U= 2.80±0.30 mm	-	-	-	-	-	-	Plastic 0.5Kp/reel

Capacitance & Voltage (Hi-Voltage X7R)

EIA Code	Size	0603					0805					1206					1210				1808			1812					
	VDCW	100	100	200	250	500	100	200	250	500	1000	1500	2000	100	200	250	500	1000	1000	1500	2000	100	200	250	500	1000	2000	3000	
101	100pF	S	B	B [^]	B [^]	B [^]																							
121	120	S	B	B [^]	B [^]	B [^]																							
151	150	S	B	B [^]	B [^]	B [^]	B [^]	B [^]	B [^]	B [^]	B [^]	B [^]	B [^]						D [^]	D [^]	D [^]								
181	180	S	B	B [^]	B [^]	B [^]	B [^]	B [^]	B [^]	B [^]	B [^]	B [^]	B [^]						D [^]	D [^]	D [^]								
221	220	S	B	B [^]	B [^]	B [^]	B [^]	B [^]	B [^]	B [^]	B [^]	B [^]	B [^]						D [^]	D [^]	D [^]								
271	270	S	B	B [^]	B [^]	B [^]	B [^]	B [^]	B [^]	B [^]	B [^]	B [^]	B [^]						D [^]	D [^]	D [^]					D [^]	D [^]		
331	330	S	B	B [^]	B [^]	B [^]	B [^]	B [^]	B [^]	B [^]	B [^]	B [^]	B [^]						D [^]	D [^]	D [^]					D [^]	D [^]		
391	390	S	B	B [^]	B [^]	B [^]	B [^]	B [^]	B [^]	B [^]	B [^]	B [^]	C [^]						D [^]	D [^]	D [^]					D [^]	D [^]		
471	470	S	B	B [^]	B [^]	B [^]	B [^]	B [^]	B [^]	B [^]	B [^]	B [^]	C [^]						D [^]	D [^]	D [^]					D [^]	D [^]		
561	560	S	B	B [^]	B [^]	B [^]	B [^]	B [^]	B [^]	B [^]	B [^]	B [^]	C [^]						D [^]	D [^]	D [^]					D [^]	D [^]		
681	680	S	B	B [^]	B [^]	B [^]	B [^]	B [^]	B [^]	B [^]	B [^]	B [^]	C [^]	C [^]					D [^]	D [^]	D [^]					D [^]	D [^]	K [^]	
821	820	S	B	B [^]	B [^]	B [^]	B	B [^]	B [^]	B [^]	B [^]	B [^]	G [^]	G [^]					D [^]	D [^]	D [^]					D [^]	D [^]	K [^]	
102	1000pF	S	B	B [^]	B [^]	B [^]	B	B [^]	B [^]	B [^]	B [^]	B [^]	G [^]	G [^]	C [^]	C [^]	C [^]	C [^]	C [^]	C [^]	D [^]	D [^]	K [^]	D [^]	D [^]	D [^]	D [^]	D [^]	K [^]
122	1200	S	B	B [^]	B [^]	B [^]	B [^]	B [^]	B [^]	B [^]	B [^]	B [^]	G [^]		C [^]	C [^]	C [^]	C [^]	C [^]	D [^]	D [^]	K [^]	D [^]	D [^]	D [^]	D [^]	D [^]	D [^]	
152	1500	S	B	B [^]	B [^]	B [^]	B [^]	B [^]	B [^]	B [^]	B [^]	B [^]	C [^]	G [^]	C [^]	C [^]	C [^]	C [^]	C [^]	D [^]	D [^]	K [^]	D [^]	D [^]	D [^]	D [^]	D [^]	D [^]	
182	1800	S	B	B [^]	B [^]	B [^]	B	B [^]	B [^]	B [^]	B [^]	B [^]	C [^]	G [^]	C [^]	C [^]	C [^]	C [^]	C [^]	D [^]	D [^]	K [^]	D [^]	D [^]	D [^]	D [^]	D [^]	D [^]	
222	2200	S	B	B [^]	B [^]	B [^]	B	B [^]	B [^]	B [^]	B [^]	B [^]	D [^]	G [^]	C [^]	C [^]	C [^]	C [^]	C [^]	D [^]	D [^]	K [^]	D [^]	D [^]	D [^]	D [^]	D [^]	D [^]	
272	2700	S	B	B [^]	B [^]	B [^]	B [^]	B [^]	B [^]	B [^]	B [^]	B [^]	G [^]		C [^]	C [^]	C [^]	C [^]	C [^]	D [^]	D [^]	D [^]	D [^]	D [^]	D [^]	D [^]	D [^]	D [^]	
332	3300	S	B	B [^]	B [^]	B [^]	B	B [^]	B [^]	B [^]	B [^]	B [^]	G [^]		C [^]	C [^]	C [^]	C [^]	C [^]	D [^]	D [^]	K [^]	D [^]	D [^]	D [^]	D [^]	D [^]	K [^]	
392	3900	S	B	B [^]	B [^]	B [^]	B	B [^]	B [^]	B [^]	B [^]	B [^]	G [^]		C [^]	C [^]	C [^]	C [^]	C [^]	D [^]	D [^]		D [^]	D [^]	D [^]	D [^]	D [^]	K [^]	
472	4700	S	B	B [^]	B [^]	B [^]	B	B [^]	B [^]	B [^]	B [^]	B [^]			C [^]	C [^]	C [^]	C [^]	C [^]	D [^]	D [^]		D [^]	D [^]	D [^]	D [^]	D [^]	K [^]	
562	5600	S	B	D [^]	D [^]	D [^]	B	B [^]	B [^]	B [^]	B [^]	B [^]			C [^]	C [^]	C [^]	C [^]	C [^]	K [^]			D [^]	D [^]	D [^]	D [^]	D [^]		
682	6800	S	B	D [^]	D [^]	D [^]	B	B [^]	B [^]	B [^]	B [^]	B [^]			C [^]	C [^]	C [^]	C [^]	C [^]	K [^]			D [^]	D [^]	D [^]	D [^]	D [^]		
822	8200	S	B	D [^]	D [^]	D [^]	B	B [^]	B [^]	B [^]	B [^]	B [^]	C [^]		C	C [^]	C [^]	C [^]	C [^]	K [^]			D [^]	D [^]	D [^]	D [^]	D [^]		
103	0.01µF	S	B	D [^]	D [^]	D [^]	B	B [^]	B [^]	B [^]	B [^]	B [^]	C [^]		C	C [^]	C [^]	C [^]	C [^]	K [^]			D [^]	D [^]	D [^]	D [^]	D [^]		
123	0.012		B				B	B [^]	B [^]	B [^]	B [^]	B [^]			C	C [^]	C [^]	C [^]	C [^]				D [^]	D [^]	D [^]	D [^]	D [^]	K [^]	
153	0.015		B				B	C [^]	C [^]	C [^]	C [^]	C [^]			C	C [^]	C [^]	C [^]	C [^]				D [^]	D [^]	D [^]	D [^]	D [^]	K [^]	
183	0.018		B				B	C [^]	C [^]	C [^]	C [^]	C [^]			C	C [^]	C [^]	C [^]	C [^]				D [^]	D [^]	D [^]	D [^]	D [^]		
223	0.022		B				B	C [^]	C [^]	C [^]	C [^]	C [^]			C	C [^]	C [^]	C [^]	C [^]	D [^]			D [^]	D [^]	D [^]	D [^]	D [^]		
273	0.027		D				B	C [^]	C [^]	C [^]	C [^]	C [^]			C	C [^]	C [^]	C [^]	C [^]				D [^]	D [^]	D [^]	D [^]	D [^]		
333	0.033		D				B	G [^]	G [^]	G [^]	G [^]	G [^]			C	C [^]	C [^]	C [^]	C [^]				D [^]	D [^]	D [^]	D [^]	D [^]		
393	0.039						B	G [^]	G [^]	G [^]	G [^]	G [^]			C	C [^]	C [^]	C [^]	C [^]				D [^]	D [^]	D [^]	D [^]	D [^]		
473	0.047						B	G [^]	G [^]	G [^]	G [^]	G [^]			C	D [^]	D [^]	D [^]	D [^]				D [^]	D [^]	D [^]	D [^]	D [^]		
563	0.056						B								C	D [^]	D [^]	D [^]	D [^]				D [^]	D [^]	D [^]	D [^]	D [^]	K [^]	
683	0.068						B								C									D [^]	D [^]	D [^]	D [^]	D [^]	K [^]
823	0.082						D								C									D	D [^]	D [^]	D [^]	D [^]	K [^]
104	0.1µF						D								C									D	D [^]	D [^]	D [^]	D [^]	K [^]
124	0.12														C									D	D [^]	D [^]	D [^]	D [^]	
154	0.15														D									D	D [^]	D [^]	D [^]	D [^]	K [^]
184	0.18														D									D	D [^]	D [^]	D [^]	D [^]	K [^]
224	0.22														D									D	D [^]	D [^]	D [^]	D [^]	K [^]
274	0.27																							D					
334	0.33																							D					
394	0.39																							D					
474	0.47																							D					
564	0.56																							K					
684	0.68																							K					
824	0.82																							K					
105	1µF																												

(1) [^]: The said items are made by NME (Noble Metal Electrode).

Size Unit: Inch (mm)	0402 (1005)	0603 (1608)	0805 (2012)	1206 (3216)	1210 (3225)	1808 (4520)	1812 (4532)
A= 0.60±0.10 mm	-	-	Paper 4Kp/reel	-	-	-	-
B= 0.80±0.10 mm	-	-	Paper 4Kp/reel	Paper 4Kp/reel	-	-	-
C= 0.95±0.10 mm	-	-	-	Plastic 3Kp/reel	Plastic 3Kp/reel	-	-
D= 1.25±0.10 mm	-	-	Plastic 3Kp/reel	Plastic 3Kp/reel	Plastic 3Kp/reel	Plastic 2Kp/reel	Plastic 1Kp/reel
G= 1.60±0.20 mm	-	-	-	Plastic 2Kp/reel	Plastic 2Kp/reel	-	-
S= 0.80±0.07 mm	-	Paper 4Kp/reel	-	-	-	-	-
N= 0.50±0.05 mm	Paper 10Kp/reel	-	-	-	-	-	-
K= 2.00±0.20 mm	-	-	-	-	Plastic 2Kp/reel	Plastic 1Kp/reel	Plastic 1Kp/reel
M= 2.50±0.30 mm	-	-	-	-			

Capacitance & Voltage (Y5V)

EIA Code	Size	0402					0603					0805					1206					1210				1812				
		6.3V	10V	16V	25V	50V	6.3V	10V	16V	25V	50V	6.3V	10V	16V	25V	50V	10V	16V	25V	35V	50V	10V	16V	25V	50V	10V	16V	25V	50V	
102	1000pF																													
122	1200																													
152	1500																													
182	1800																													
222	2200																													
272	2700																													
332	3300																													
392	3900																													
472	4700																													
562	5600																													
682	6800																													
822	8200																													
103	0.01µF		N	N	N	N		S	S	S	S		A	A	A	A	B	B	B		B									
123	0.012		N	N	N	N		S	S	S	S		A	A	A	A	B	B	B		B									
153	0.015		N	N	N	N		S	S	S	S		A	A	A	A	B	B	B		B									
183	0.018		N	N	N	N		S	S	S	S		A	A	A	A	B	B	B		B									
223	0.022		N	N	N	N		S	S	S	S		A	A	A	A	B	B	B		B									
273	0.027		N	N	N	N		S	S	S	S		A	A	A	A	B	B	B		B									
333	0.033		N	N	N	N		S	S	S	S		A	A	A	A	B	B	B		B									
393	0.039		N	N	N			S	S	S	S		A	A	A	A	B	B	B		B									
473	0.047		N	N	N			S	S	S	S		A	A	A	A	B	B	B		B									
563	0.056		N	N				S	S	S	S		A	A	A	A	B	B	B		B									
683	0.068		N	N				S	S	S	S		A	A	A	A	B	B	B		B									
823	0.082		N	N				S	S	S	S		A	A	A	A	B	B	B		B									
104	0.1µF		N	N				S	S	S	S		A	A	A	A	B	B	B		B	C	C	C	C	D	D	D	D	
154	0.15		N					S	S	S	S		A	A	A	A	B	B	B		B	C	C	C	C	D	D	D	D	
224	0.22		N					S	S	S	S		A	A	A	A	B	B	B		B	C	C	C	C	D	D	D	D	
334	0.33	N	N					S	S	S			B	B	B	B	B	B	B		B	C	C	C	C	D	D	D	D	
474	0.47	N	N					S	S	S			B	B	B		B	B	B		B	C	C	C	C	D	D	D	D	
684	0.68							S					B	B	D		B	B	B		B	C	C	C	C	D	D	D	D	
105	1µF	N						S	S				B	B	D	D'	C	C	C		C	C	C	C	D	D	D	D	D	
155	1.5												D	D			C	C	C			C	C	C		D	D	D	D	
225	2.2						S						D	D			C	C	C		D'	C	C	C		D	D	D	D	
335	3.3												D				D	D	D			C	C	C		D	D	D	D	
475	4.7						S						D	D'			D	D	D'	D'		C	C	D	G	D	D	D	D	
685	6.8																D	D'				C	C			D	D	D	D	
106	10µF										D'	D'					D	D'				D	D	G		D	D	D		
226	22µF																G'					K	K							
476	47µF																					K								

(1) [D']: The thickness spec. of said items is special defined on 1.25±0.2mm for 0805 and 1.15±0.15mm for 1206.
 (2) [G']: The thickness spec. of said items is special defined on 1.60+0.3/-0.1mm.

Size Unit: Inch (mm)	0402 (1005)	0603 (1608)	0805 (2012)	1206 (3216)	1210 (3225)	1808 (4520)	1812 (4532)
A= 0.60±0.10 mm	-	-	Paper 4Kp/reel	-	-	-	-
B= 0.80±0.10 mm	-	-	Paper 4Kp/reel	Paper 4Kp/reel	-	-	-
C= 0.95±0.10 mm	-	-	-	Plastic 3Kp/reel	Plastic 3Kp/reel	-	-
D= 1.25±0.10 mm	-	-	Plastic 3Kp/reel	Plastic 3Kp/reel	Plastic 3Kp/reel	Plastic 2Kp/reel	Plastic 1Kp/reel
G= 1.60±0.20 mm	-	-	-	Plastic 2Kp/reel	Plastic 2Kp/reel	-	-
S= 0.80±0.07 mm	-	Paper 4Kp/reel	-	-	-	-	-
N= 0.50±0.05 mm	Paper 10Kp/reel	-	-	-	-	-	-
K= 2.00±0.20 mm	-	-	-	-	Plastic 2Kp/reel	Plastic 1Kp/reel	Plastic 1Kp/reel

Capacitance & Voltage (Hi-Voltage Y5V)

EIA Code	Size VDCW	0805			1206			1210			1812		
		100	200	250	100	200	250	100	200	250	100	200	250
103	0.01µF	B	B	B	B	B	B	C	C	C	D	D	D
153	0.015	B	B	B	B	B	B	C	C	C	D	D	D
223	0.022	B	B	B	B	B	B	C	C	C	D	D	D
333	0.033	B	B	B	B	B	B	C	C	C	D	D	D
473	0.047	B	B	B	B	B	B	C	C	C	D	D	D
683	0.068	B	B	B	B	B	B	C	C	C	D	D	D
104	0.1µF	B			B	B	B	C	C	C	D	D	D
154	0.15				C	C	C	C	C	C	D	D	D
224	0.22				C			C			D	D	D
334	0.33							C			D	D	D
474	0.47										D	D	D
684	0.68										D	D	D
105	1µF										D		

Size Unit: Inch (mm)	0805 (2012)	1206 (3216)	1210 (3225)	1812 (4532)
A= 0.60±0.10 mm	Paper 4Kp/reel	-	-	-
B= 0.80±0.10 mm	Paper 4Kp/reel	Paper 4Kp/reel	-	-
C= 0.95±0.10 mm	-	Plastic 3Kp/reel	Plastic 3Kp/reel	-
D= 1.25±0.10 mm	Plastic 3Kp/reel	Plastic 3Kp/reel	Plastic 3Kp/reel	Plastic 1Kp/reel
G= 1.60±0.20 mm	-	Plastic 2Kp/reel	-	-
S= 0.80±0.07 mm	-	-	-	-
N= 0.50±0.05 mm	-	-	-	-
K= 2.00±0.20 mm	-	-	-	Plastic 1Kp/reel
M= 2.50±0.30 mm	-	-	-	-

Packaging

Chip Size	Paper Tape			Plastic Tape			Chip Thickness
	Width (reel)	Thickness	Unit/Reel	Width (reel)	Thickness	Unit/Reel	
0402	8mm (7")	N	10Kp/Reel				A=0.50-0.70
	8mm (7")	S	4Kp/Reel				
0603	8mm (10")	S	10Kp/Reel				B=0.85+0.05/-0.15
	8mm (13")	S	15Kp/Reel				
0805	8mm (7")	A, B	4Kp/Reel	8mm (7")	C, D	3Kp/Reel	C=1.00+0.05/-0.13
	8mm (10")	A, B	10Kp/Reel	8mm (10")	C, D	3Kp/Reel	D=1.20±0.15
	8mm (13")	A, B	15Kp/Reel	8mm (13")	C, D	3Kp/Reel	S=0.80±0.07
1206	8mm (7")	A, B	4Kp/Reel	8mm (7")	C, D	3Kp/Reel	H=0.50-0.60
	8mm (10")	A, B	10Kp/Reel	8mm (10")	C, D	3Kp/Reel	E=0.65-0.75
	8mm (13")	A, B	15Kp/Reel	8mm (13")	C, D	3Kp/Reel	
				8mm (7")	F, G	3Kp/Reel	N=0.50±0.05
1210				8mm (7")	K	3Kp/Reel	F=1.40+0.05/-0.15
				8mm (7")	C, D	3Kp/Reel	
				8mm (7")	F	3Kp/Reel	
1808				12mm (7")	C, G	3Kp/Reel	G=1.60+0.05/-0.15
				12mm (7")	K	3Kp/Reel	
1812				12mm (7")	D	3Kp/Reel	K=2.00±0.10

Type TYC Series

Packaging (continued)

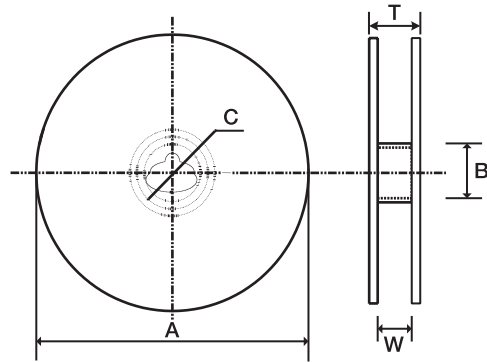

ϕA	ϕB	ϕC	W
178±1 (7")	60.5±1		9.0±1
	80±1	13.0±1	13.5±1
250±1 (10")	62.5±1		9.0±1
330±1 (13")	100±1		9.0±1

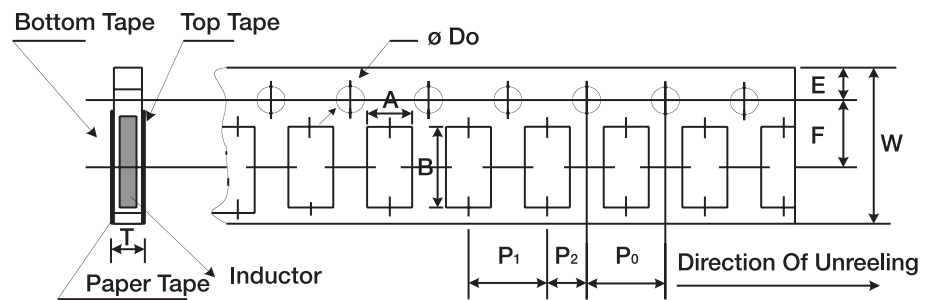

Type	A	B	W	ϕD_0	E	F	P_0	P_1	P_2	T
0402	0.7±0.05	1.23±0.05								0.6±0.05
0603	1.0±0.1	1.84±0.1								
0805	1.55±0.2	2.35±0.2	8.0±0.32	1.55±0.05	1.70±0.1	3.50±0.1	4.0±0.1	4.0±0.1	2.0±0.1	<1.0
1206	2.0±0.2	3.5±0.2								

How to Order

TYC	0201	A	101	B	C	T
Common Part	Size	Dielectric	Capacitance Code	Tolerance	Voltage	Packaging
TYC - Multilayer Ceramic Chip Capacitor	0201					
	0402	A = NPO	101 - 100pF	B = 0.1pF C = 0.25pF D = 0.5pF	C = 6.3V D = 10V E = 16V F = 25V G = 50V H = 100V J = 200V L = 500V P = 1KV Q = 2KV R = 3KV S = 4KV	T = Paper (7") P = Plastic (7")
	0603	B = X7R	102 - 1000pF	F = +/- 1% G = +/- 2% J = +/- 5% K = +/- 10% M = +/- 20% Z = +80%/-20%		
	0805	C = X5R	103 - 0.01uF			
	1206	D = Y5V				