

Ceramic Disc Capacitors

Class 1 and 2, 500 V_{DC}, General Purpose



Capacitors with 5 mm (0.20") and 7.5 mm (0.30") lead spacing

QUICK REFERENCE DATA		
DESCRIPTION	CLASS 1 (C0G (NP0), SL0)	CLASS 2 (Y5P, Z5U, Y5V, X5F)
Voltage (V _{DC})	500	
Min. Capacitance (pF)	10	100
Max. Capacitance (pF)	82	22 000
Mounting	Through hole	

MARKING

Marking indicates capacitance value and tolerance in accordance with "EIA 198".

The capacitors meet the essential requirements of "EIA 198". Unless stated otherwise all electrical values apply at an ambient temperature of 25 °C ± 3 °C, at normal atmospheric conditions.

OPERATING TEMPERATURE RANGE

Class 1, - 55 °C to + 125 °C

Class 2, - 55 °C to + 85 °C

TEMPERATURE COEFFICIENTS

Class 1, C0G (NP0); SL0

Class 2, Y5P; Z5U; Y5V; X5F

SECTIONAL SPECIFICATIONS

Class 1, IEC 60 384-8

Class 2, IEC 60 384-9

EIA 198

CLIMATIC CATEGORY

Class 1, 55/125/21

Class 2, 10/85/21, 30/85/21 and 55/85/21

FEATURES

- Low losses
- High stability
- High capacitance in small size
- Kinked (preferred) or straight leads
- Compliant to RoHS directive 2002/95/EC



RoHS
COMPLIANT

APPLICATIONS

- Bypassing
- Coupling
- Resonant circuit

DESIGN

The capacitors consist of a ceramic disc both sides of which are silver-plated. Connection leads are made of tinned copper having a diameter of 0.6 mm.

The capacitors have inward kinked leads with a spacing of 5 mm (0.200") or 7.5 mm (0.300") and a lead length from 4 mm to 30 mm. Encapsulation is made of phenolic resin.

CAPACITANCE RANGE

Class 1, at 1 MHz, 1.2 V_{RMS}; 10 pF to 82 pF

Class 2, at 1 kHz, 1 ± 0.2 V_{RMS}; 100 pF to 22 000 pF

1 kHz, 1 V_{RMS} ± 0.2 V_{RMS} for capacitance values higher than 1000 pF

RATED DC VOLTAGE

500 V

DIELECTRIC STRENGTH

250 % of rated voltage

INSULATION RESISTANCE AT 500 V_{DC}

≥ 10 000 MΩ

TOLERANCE ON CAPACITANCE

± 5 %; ± 10 %; ± 20 %; + 80/- 20 %

DISSIPATION FACTOR

Class 1, C ≤ 30 pF; ≤ 20 x (10/C + 0.7) x 10⁻⁴ maximum

Class 1, C > 30 pF; ≤ 0.2 %

Class 2, ≤ 3.0 %



Ceramic Disc Capacitors
Class 1 and 2, 500 V_{DC}, General Purpose

Vishay BCcomponents

ORDERING INFORMATION (PREFERRED TYPES), CLASS 1, 500 V_{DC}, KINKED					
C (pF)	TOL. (%)	D _{MAX.} (mm)	LEAD SPACING (mm)	SH ⁽¹⁾ (mm)	CLEAR TEXT CODE
					13 TH DIGIT: T = REEL; U = AMMO; 3 = BULK 16 TH DIGIT: R = RoHS COMPLIANT
CLASS 1 NP0					
10	± 5	5.0	5.0	4.0	D100J20C0GL6.J5.
12					D120J20C0GL6.J5.
15					D150J20C0GL6.J5.
18		6.5			D180J25C0GL6.J5.
22					D220J25C0GL6.J5.
27					D270J25C0GL6.J5.
CLASS 1 SL0					
33	± 5	5.0	5.0	4.0	D330J20SL0L6.J5.
39					D390J20SL0L6.J5.
47					D470J20SL0L6.J5.
56		6.5			D560J20SL0L6.J5.
68					D680J25SL0L6.J5.
82					D820J25SL0L6.J5.

Notes

⁽¹⁾ SH = seated height

- Maximum thickness 4.0 mm
- Lead style codes refer to inward kinked leads. Other styles available on request

ORDERING INFORMATION (PREFERRED TYPES), CLASS 2, 500 V_{DC}, KINKED						
C (pF)	TOL. (%)	D _{MAX.} (mm)	LEAD SPACING (mm)	SH ⁽¹⁾ (mm)	CLEAR TEXT CODE	
					13 TH DIGIT: T = REEL; U = AMMO; 3 = BULK 16 TH DIGIT: R = RoHS COMPLIANT	
CLASS 2 Y5P						
100	± 10	5	5	4.0	D101K20Y5PL6.J5.	
150					D151K20Y5PL6.J5.	
220					D221K20Y5PL6.J5.	
330					D331K20Y5PL6.J5.	
470					D471K20Y5PL6.J5.	
680					6.5	D681K25Y5PL6.J5.
1000		D102K25Y5PL6.J5.				
1500		7.5			D152K29Y5PL6.J5.	
2200		8.5			D222K33Y5PL6.J5.	
3300		10			D332K39Y5PL6.J5.	
4700		11			D472K43Y5PL6.J5.	
6800		13.5			7.5	D682K53Y5PL6.J7
10 000						D103K69Y5PL6.J7.
CLASS 2 Y5V						
1000	+ 80/- 20	5	5	4.0	D102Z20Y5VL6.J5.	
1500					D152Z20Y5VL6.J5.	
2200					6.5	D222Z25Y5VL6.J5.
3300		D322Z25Y5VL6.J5.				
4700		7.5			D472Z29Y5VL6.J5.	
6800		8.5			D682Z33Y5VL6.J5.	
10 000		10.0			D103Z39Y5VL6.J5.	
15 000		11.0			D153Z43Y5VL6.J5.	
22 000		13.5			7.5	D223Z53Y5VL6.J7.

ORDERING INFORMATION (PREFERRED TYPES), CLASS 2, 500 V _{DC} , KINKED						
C (pF)	TOL. (%)	D _{MAX.} (mm)	LEAD SPACING (mm)	SH ⁽¹⁾ (mm)	CLEAR TEXT CODE	
					13 TH DIGIT: T = REEL; U = AMMO; 3 = BULK 16 TH DIGIT: R = RoHS COMPLIANT	
CLASS 2 Z5U						
1000	± 20	5.0	5.0	4.0	D102M20Z5UL6.J5.	
1500					D152M25Z5UL6.J5.	
2200					D222M25Z5UL6.J5.	
3300					7.5	D332M29Z5UL6.J5.
4700					8.5	D472M33Z5UL6.J5.
6800					10.0	D682M39Z5UL6.J5.
10 000		11.0	D103M43Z5UL6.J5.			
15 000		13.5	D153M53Z5UL6.J7.			
22 000		15.0	7.5		D223M59Z5UL6.J7.	
CLASS 2 X5F						
1 00	± 10	5.0	5.0	4.0	D101K20X5FL6.J5.R.	
2 20					D221K20X5FL6.J5.R.	
330					D331K20X5FL6.J5.R.	
470					6.5	D471K25X5FL6.J5.R.
680					7.5	D681K25X5FL6.J5.R.
1000					10.0	D102K29X5FL6.J5.R.
2200		12.0	D222K39X5FL6.J5.R.			
3300		13.5	7.5		D332K47X5FL6.J7R.	
4700					4.8	D472K53X5FL6.J7R.

Note

- (1) SH = seated height
- Maximum thickness 4.0 mm
- Lead style codes refer to inward kinked leads. Other styles available on request

PACKAGING				
D _{MAX.} (mm)	SIZE CODE	PACKAGING QUANTITIES		
		BULK	REEL	AMMO
5.0 (0.20")	20	1000	2000	2000
6.5 (0.25")	25			
7.5 (0.29")	29			
8.5 (0.33")	33			
10.0 (0.39")	39			
11.0 (0.43")	43			
12.0 (0.47")	47	500	-	-
13.5 (0.53")	53			
15.0 (0.59")	59			
17.5 (0.69")	69			

Note

- The capacitors are supplied in bulk packaging (cardboard boxes), in tape on reel or in ammpack.

Ceramic Disc Capacitors
Class 1 and 2, 500 V_{DC}, General Purpose

Vishay BCcomponents

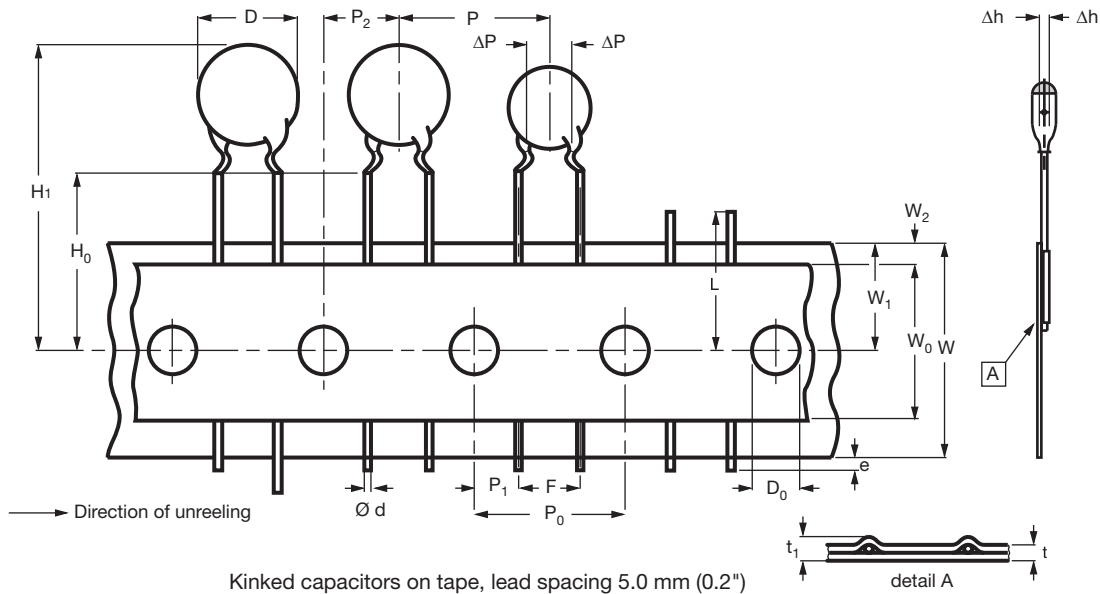

DIMENSIONS OF TAPE			
SYMBOL	PARAMETER	DIMENSIONS (mm)	
		NOMINAL	TOLERANCE
D	Body diameter	11.0 maximum	-
d	Lead diameter	0.6	± 0.05
P ⁽¹⁾	Pitch between capacitors	12.7	± 1.0
P ₀	Feed-hole pitch	12.7	± 0.3
ΔP	Plane deviation	1.0 maximum	-
P ₁ ⁽²⁾	Feed-hole center to lead center	3.85	± 0.7
P ₂ ⁽²⁾	Feed-hole center to component center	6.35	± 1.3
F	Lead spacing	5.0	0.6 - 0.4
Δh	Component alignment	0	± 1.0
W	Tape width	18.0	1.0 - 0.5
W ₀	Hold-down tape width	5.0 minimum	-
W ₁	Hole position	9.0	0.75 - 0.5
W ₂	Hold-down tape margin	3.0 maximum	-
H ₀	Height to seating plane	16.0	± 0.5
H ₁	Maximum component height	32.0	-
e	Lead end protrusion	1.0 maximum	-
L	Maximum length of snapped lead	11.0	-
D ₀	Feed-hole diameter	4.0	± 0.2
t	Total tape thickness	0.9 maximum	-
t ₁	Maximum thickness of tape and wires	1.5 maximum	-

Notes

⁽¹⁾ Cumulative pitch error: ± ≤ 1 mm/20 pitches

⁽²⁾ Obliquity maximum 3°

D Series

Vishay BCcomponents

Ceramic Disc Capacitors
Class 1 and 2, 500 V_{DC}, General Purpose



REEL AND TAPE DATA in millimeters

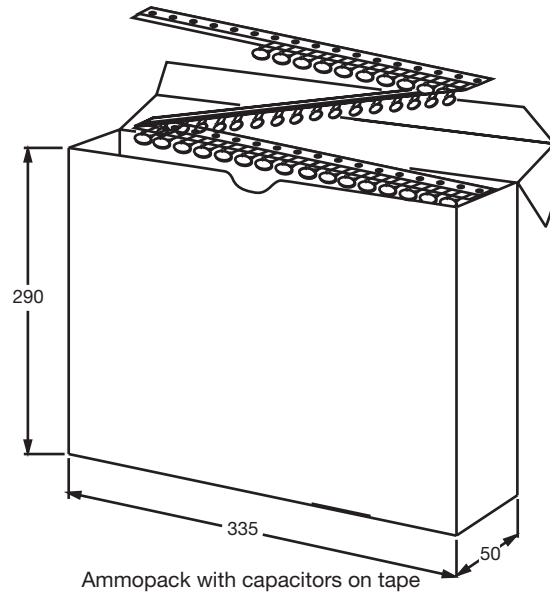
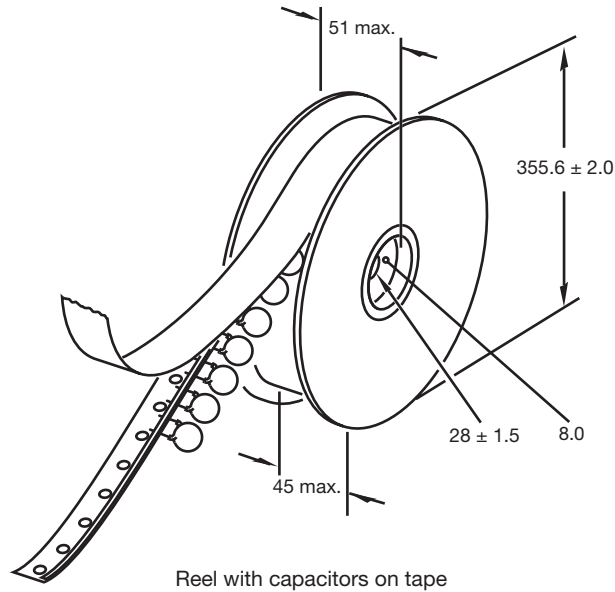



Disclaimer

All product specifications and data are subject to change without notice.

Vishay Intertechnology, Inc., its affiliates, agents, and employees, and all persons acting on its or their behalf (collectively, "Vishay"), disclaim any and all liability for any errors, inaccuracies or incompleteness contained herein or in any other disclosure relating to any product.

Vishay disclaims any and all liability arising out of the use or application of any product described herein or of any information provided herein to the maximum extent permitted by law. The product specifications do not expand or otherwise modify Vishay's terms and conditions of purchase, including but not limited to the warranty expressed therein, which apply to these products.

No license, express or implied, by estoppel or otherwise, to any intellectual property rights is granted by this document or by any conduct of Vishay.

The products shown herein are not designed for use in medical, life-saving, or life-sustaining applications unless otherwise expressly indicated. Customers using or selling Vishay products not expressly indicated for use in such applications do so entirely at their own risk and agree to fully indemnify Vishay for any damages arising or resulting from such use or sale. Please contact authorized Vishay personnel to obtain written terms and conditions regarding products designed for such applications.

Product names and markings noted herein may be trademarks of their respective owners.