





Messrs.					
Product Specification	Model:	MTF-TQ35SN941-LB	Rev. No.	Issued Date.	Page.
			A	December.14,09	1 / 32

LIQUID CRYSTAL DISPLAY MODULE
MODEL: MTF-TQ35SN941-LB
Customer's No.:

Acceptance

Microtips Technology Inc.
12F. No.31 Lane 169, Kang Ning St.,
His-Chih, Taipei Hsien, Taiwan
FAX: 886-2-26958625

Approved and Checked by

Approved by	Checked by		Made by
			



Microtips Technology Inc.

Messrs.					
Product Specification	Model:	MTF-TQ35SN941-LB	Rev. No.	Issued Date.	Page.
			A	December.14,09	3 / 32

Contents

1. GENERAL DESCRIPTION AND FEATURES	5
1.1 Features	5
1.2 General Specifications.....	5
2. ABSOLUTE MAXIMUM RATINGS	6
2.1 Absolute Ratings of Environment	6
3. ELECTRICAL CHARACTERISTICS	7
3.1 Operating Conditions:	7
3.2 LED driving Conditions.....	7
4. DC CHARATERISTICS	8
5. AC CHARACTERISTICS	8
5.1 Digital Parallal RGB Interface	8
5.1-1 Digital Serial RGB Interface	9
5.1-2 CCIR601 / 656 Interface	9
5.2 Waveform	10
5.2-1 Standby ON / OFF Control.....	11
5.2-2 Clock and Sync Waveforms.....	11
5.3 Reset Timing Chart	12
5.4 Digital RGB Timing Waveform.....	13
5.4-1 Hsync and horizontal control timing waveform	13
5.4-2 Hsync and vertical shift control timing waveform	13
5.4-3 Hsync and vertical control timing waveform	14
5.4-4 CCIR601 timing waveform	14
5.4-5 Source Driver Timing Chart	16
5.4-6 Gate Driver Timing Chart.....	17
6. OPTICAL CHARACTERISTICS	18
7. INPUT TERMINAL PIN ASSIGNMENT	21
7.1 LCM PIN Definition	21
7.2 SPI Timing Characteristics.....	23
7.3 SPI Register Description	24
8. BASIC DISPLAY COLOR AND GRAY SCALE	25
9. BLOCK DIAGRAM	26
10. QUALITY ASSURANCE	27



Microtips Technology Inc.

Messrs.					
Product Specification	Model:	MTF-TQ35SN941-LB	Rev. No.	Issued Date.	Page.
			A	December.14,09	4 / 32

11. PRECAUTIONS	28
11.1 Operation.....	28
11.2 Safety.....	28
11.3 Handling.....	28
11.4 Static electricity.....	30
11.5 Storage.....	30
11.6 Cleaning	30
11.7 Waste	30
12. WARRANTY	31
13. DIMENSIONAL OUTLINES	31



Microtips Technology Inc.

Messrs.					
Product Specification	Model:	MTF-TQ35SN941-LB	Rev. No.	Issued Date.	Page.
			A	December.14,09	5 / 32

1. GENERAL DESCRIPTION AND FEATURES

MTF-TQ35SN941-LB is a TM (Transmissive) type color active matrix TFT (Thin Film Transistor) liquid crystal display (LCD) that uses amorphous silicon TFT devices. This model is composed of a TFT-LCD module, a driver circuit and a back-light unit. The resolution of a 3.45" contains 320RGBx240 dots and can display up to 16.7M colors. The following table described the features of MTF-TQ35SN941-LB

1.1 Features

- Support 24-bit parallel data (RGB).

1.2 General Specifications

Item	Specification	Unit	Note
Screen Size	3.45" diagonal	inch	--
Display Resolution	320 x RGB x 240	Dot	--
Dot Pitch	0.073 (W) x 0.219 (H)	mm	--
Active Area	70.08 (W) x 52.56 (H)	mm	--
Outline Dimension	76.9 (W) x 63.9 (H) x 3.3 (T), Not including FPCB	mm	--
Display Mode	Normally White / Transmissive	--	--
Pixel Arrangement	RGB-Strip	--	--
Surface Treatment	Anti-glare (AG)	--	--
Weight	40	g	--
Viewing Direction	6 o'clock	--	--
Input Interface	Digital 24-bits RGB / SERIAL RGB / CCIR656 / CCIR601	--	--
Temperature Range	Operation	-20 ~ 70	°C
	Storage	-30 ~ 80	



Microtips Technology Inc.

Messrs.					
Product Specification	Model:	MTF-TQ35SN941-LB	Rev. No.	Issued Date.	Page.
			A	December.14,09	6 / 32

2. ABSOLUTE MAXIMUM RATINGS

2.1 Absolute Ratings of Environment

If the operating condition exceeds the following absolute maximum ratings, the TFT LCD module may be damaged permanently.

(Ta = 25°C, VSS = GND = 0)

Item	Symbol	Min.	Max.	Unit	Note
Power Voltage	DVDD , AVDD	-0.3	5.0	V	--
Input Signal Voltage	Vin	-0.3	VDD+0.3	V	--
Logic Output Voltage	VOUT	-0.3	VDD+0.3	V	--

Note: Device is subject to be damaged permanently if stresses beyond those absolute maximum ratings listed above.

1. Temp \leq 60°C , 90% RH MAX.
2. Temp > 60°C , Absolute humidity shall be less than 90% RH at 60°C.

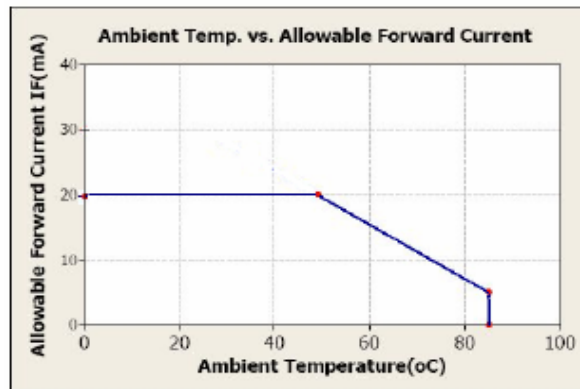

Microtips Technology Inc.

Messrs.					
Product Specification	Model:	MTF-TQ35SN941-LB	Rev. No.	Issued Date.	Page.
			A	December.14,09	7 / 32

3. ELECTRICAL CHARACTERISTICS

3.1 Operating Conditions:

(Unless otherwise specified, Voltage Referenced to Vss, VCC=3.3V, Ta=25°C)

Item	Symbol	Value			Unit	Note
		Min.	Typ.	Max.		
Power Voltage	VCC	3.0	3.3	3.6	V	--
Digital Operation Current	Icc	--	8.6	--	mA	--
Gate on Power	VGH	14	15	18	V	--
Gate off Power	VGL	-11	-10	-8	V	--
Vcom High Voltage	Vcom H	--	3.7	--	V	Note 1
Vcom Low Voltage	Vcom L	--	-1.6	--	V	Note 1
Vcom Level max	Vcom A	--	--	6	V	--

Note1: VcomH & VcomL: Adjust the color with gamma data Vp-p should be higher then 4V. (Option 5V)

Note2: Please power on following the sequence VCC → VDD.

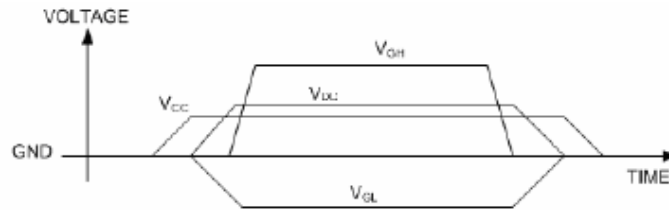

3.2 LED driving Conditions

Ta=25°C

Item	Symbol	Min.	Typ.	Max.	Unit	Note
LED Current	--	--	20	--	mA	--
Power Consumption	--	--	400	420	mW	--
LED Voltage	VBL+	18.6	19.8	21	V	Note 1
LED Life Time	--	--	(50,000)-	--	Hr	Note 2, 3

Note 1: There are 1 Groups LED.

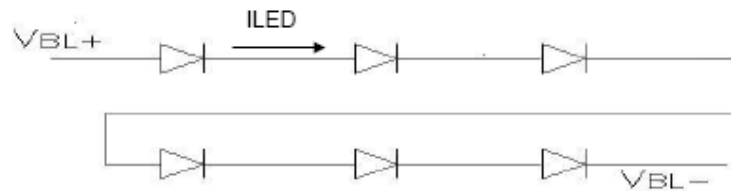

Note 2: Brightness to be decreased to 50% of the initial value.



Microtips Technology Inc.

Messrs.					
Product Specification	Model:	MTF-TQ35SN941-LB	Rev. No.	Issued Date.	Page.
			A	December.14,09	8 / 32

4. DC CHARATERISTICS

Item	Symbol	Value			Unit	Note
		Min.	Typ.	Max.		
Low Level Input Voltage	V _{IL}	0	--	0.3 VCC	V	--
Hight Level Input Voltage	V _{IH}	0.7 VCC	--	VCC	V	--

5. AC CHARACTERISTICS

5.1 Digital Parallal RGB Interface

Signal	Item	Symbol	Min.	Typ.	Max.	Unit
Dclk	Frequency	Tosc	--	156	--	ns
	High Time	Tch	--	78	--	ns
	Low Time	Tcl	--	78	--	ns
Data	Setup Time	Tus	12	--	--	ns
	Hold Time	Thd	12	--	--	ns
Hsync	Period	TH	--	408	--	Tosc
	Pulse Width	THS	5	30	--	Tosc
	Back – Porch	Thb	--	38	--	Tosc
	Display Period	TEP	--	320	--	Tosc
	Hsync – den Time	THE	36	68	88	Tosc
	Front – Porch	Thf	--	20	--	Tosc
Vsync	Period	Tv	--	262	--	TH
	Pulse Width	Tvs	1	3	5	TH
	Back – Porch	Tvb	--	15	--	TH
	Display Period	Tvd--	--	240	--	TH
	Front – Porch	Tvf1	2	4	--	TH

- Note: 1. The + Thb = 68, the user is make up by yourself.
2. Tv = Tvs + .Tvb + Tvd + Tvf, the user is make up by yourself.
3. When SYNC mode is used, 1st data start from 68th Dclk after Hsync falling.



Microtips Technology Inc.

Messrs.					
Product Specification	Model:	MTF-TQ35SN941-LB	Rev. No.	Issued Date.	Page.
			A	December.14,09	9 / 32

5.1-1 Digital Serial RGB Interface

Signal	Item	Symbol	Min.	Typ.	Max.	Unit
Dclk	Frequency	Tosc	--	52	--	ns
	High Time	Tch	--	78	--	ns
	Low Time	Tcl	--	78	--	ns
Data	Setup Time	Tus	12	--	--	ns
	Hold Time	Thd	12	--	--	ns
Hsync	Period	TH	--	1224	--	Tosc
	Pulse Width	THS	5	90	--	Tosc
	Back – Porch	Thb	--	114	--	Tosc
	Display Period	TEP	--	960	--	Tosc
	Hsync – den Time	THE	108	204	264	--
	Front – Porch	Thf	--	60	--	Tosc
Vsync	Period	Tv	--	262	--	TH
	Pulse Width	Tvs	1	3	5	TH
	Back – Porch	Tvb	--	15	--	TH
	Display Period	Tvd--	--	240	--	TH
	Front – Porch	Tvf1	2	4	--	TH

- Note: 1. $T_e + T_{hb} = 204$, the user is make up by yourself.
2. $T_v = T_{vs} + T_{vb} + T_{vd} + T_{vf}$, the user is make up by yourself.
3. When SYNC mode is used, 1st data start from 204th Dclk after Hsync falling.

5.1-2 CCIR601 / 656 Interface

Signal	Item	Symbol	Min.	Typ.	Max.	Unit
Dclk	Frequency	Tosc	--	37	--	ns
	High Time	Tch	--	78	--	ns
	Low Time	Tcl	--	78	--	ns
Data	Setup Time	Tus	12	--	--	ns
	Hold Time	Thd	12	--	--	ns



Microtips Technology Inc.

Messrs.					
Product Specification	Model:	MTF-TQ35SN941-LB	Rev. No.	Issued Date.	Page.
			A	December.14,09	10 / 32

5.2 Waveform

- CCIR601 (HS_POL = L in Register R2)

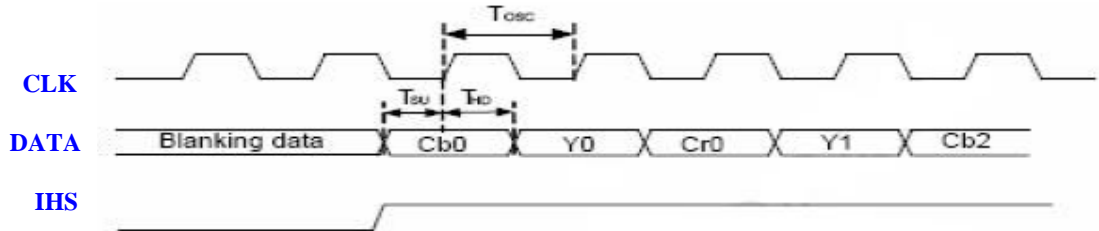

Figure1 CLK, DATA and HIS waveforms in CCIR601

- CCIR656

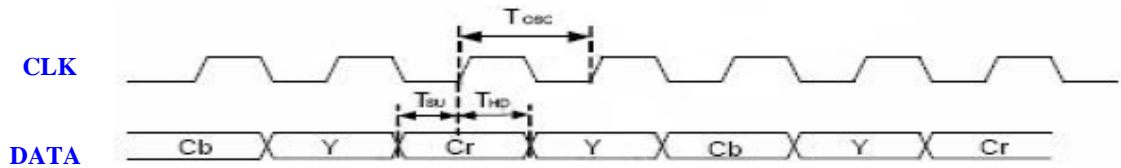

Figure2 CLK and DATA waveforms in CCIR656

- Digital Parallel RGB

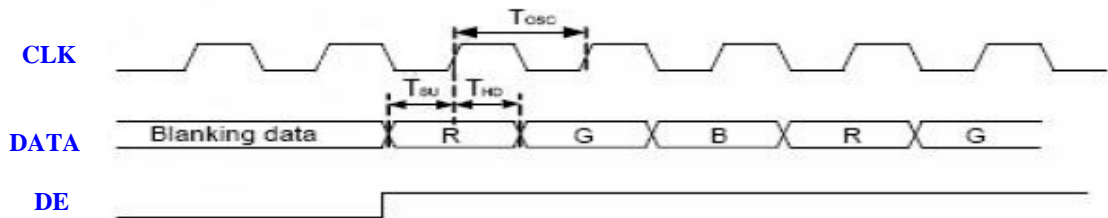

Figure3 CLK, DATA and DE waveforms in Digital Serial RGB

- Digital Parallel RGB

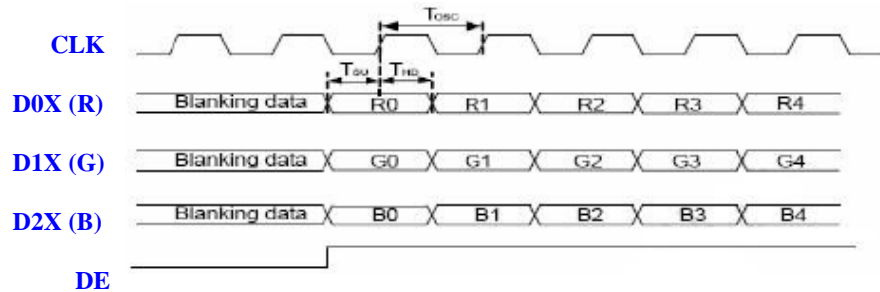

Figure4 CLK, DATA and DE waveforms in Digital Parallel RGB



Microtips Technology Inc.

Messrs.					
Product Specification	Model:	MTF-TQ35SN941-LB	Rev. No.	Issued Date.	Page.
			A	December.14,09	11 / 32

5.2-1 Standby ON / OFF Control

LQ35HC112 has a power ON/OFF sequence control function. When STB pin is pulled L, blank data is outputted for 5-frames first, from the falling edge of the following VSYNC signal. The blank data would be gray level 255 for normally white LC.

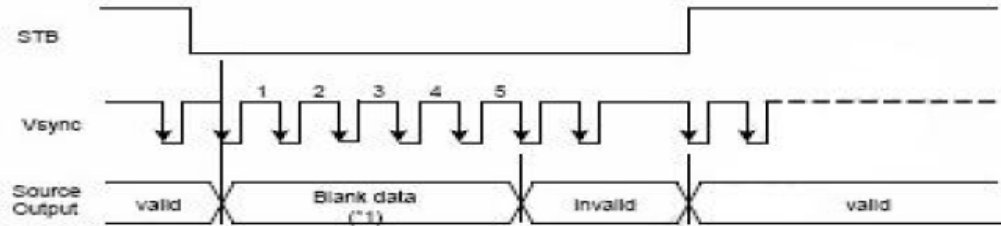

Figure5 Standby ON / OFF Control

5.2-2 Clock and Sync Waveforms

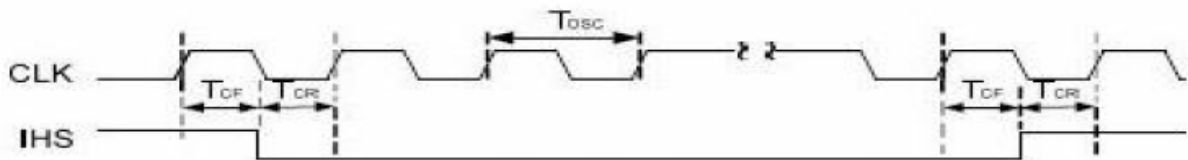

Figure6 CLK and HIS Timing Waveform

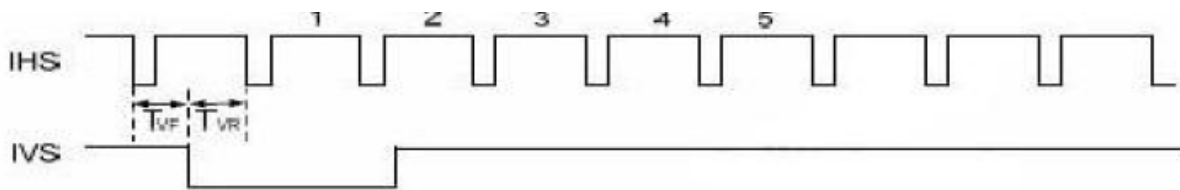
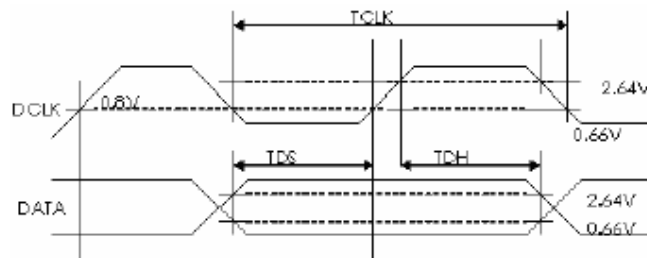
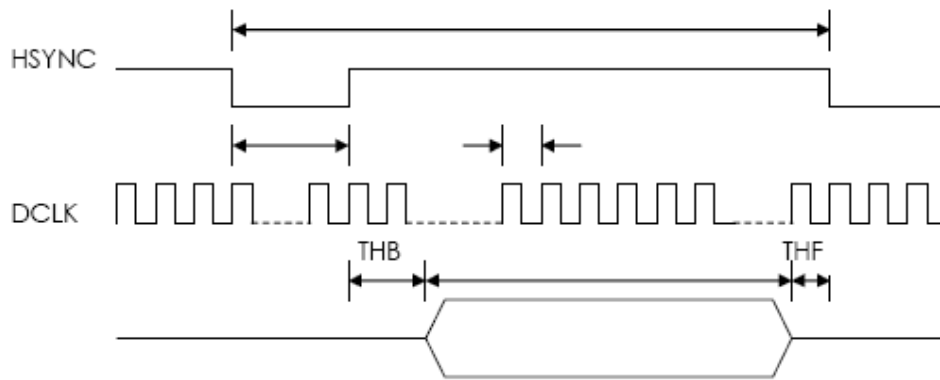
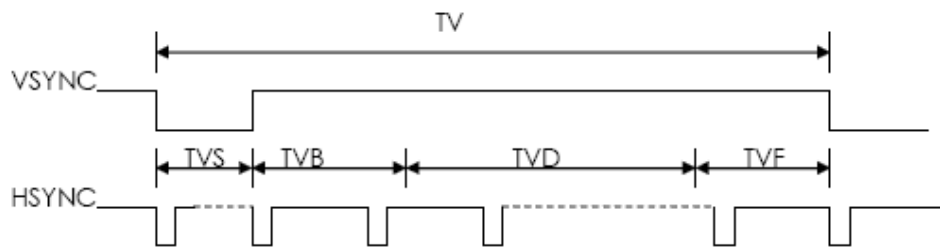

Figure7 IHS and IVS Timing Waveform



Microtips Technology Inc.

Messrs.					
Product Specification	Model:	MTF-TQ35SN941-LB	Rev. No.	Issued Date.	Page.
			A	December.14,09	12 / 32



5.3 Reset Timing Chart

The RESET input must be held at least 1ms after power is stable

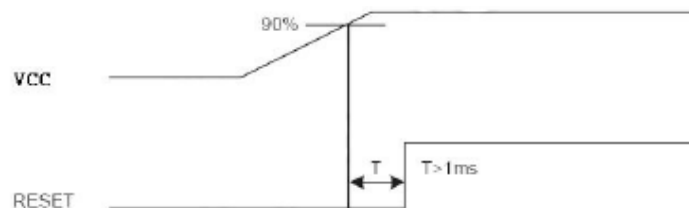

Reset timing



Microtips Technology Inc.

Messrs.					
Product Specification	Model:	MTF-TQ35SN941-LB	Rev. No.	Issued Date.	Page.
			A	December.14,09	13 / 32

5.4 Digital RGB Timing Waveform Hsync and Vsync Timing

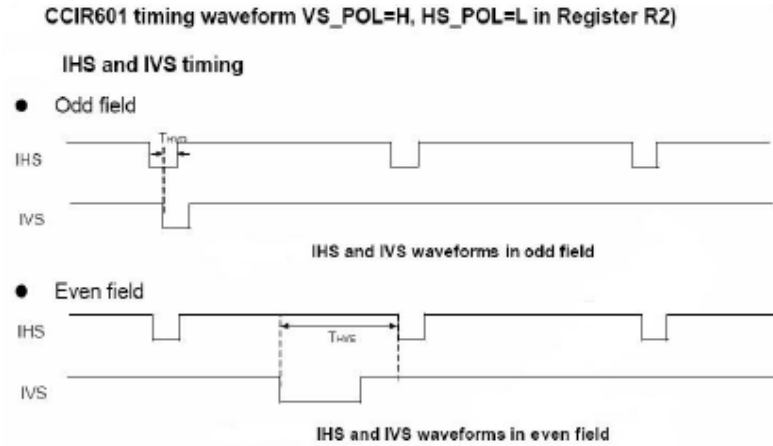

5.4-1 Hsync and horizontal control timing waveform

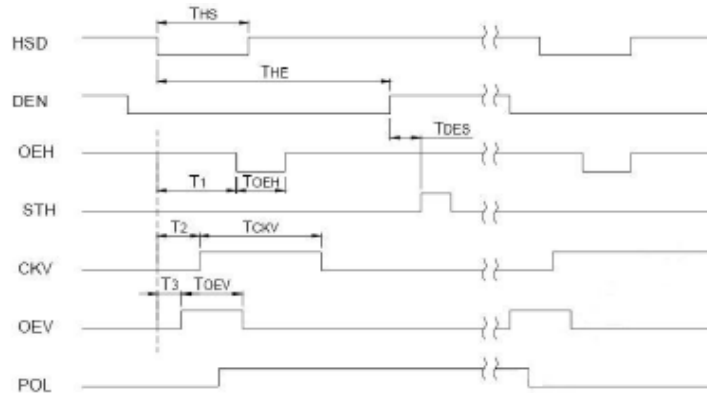

5.4-2 Hsync and vertical shift control timing waveform

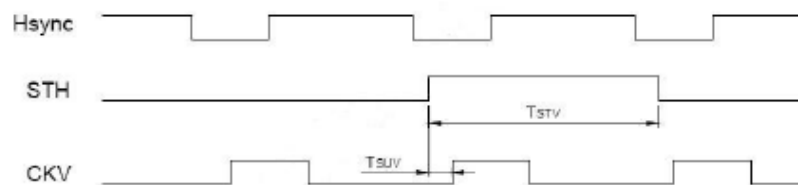

Microtips Technology Inc.

Messrs.					
Product Specification	Model:	MTF-TQ35SN941-LB	Rev. No.	Issued Date.	Page.
			A	December.14,09	14 / 32

5.4-3 Hsync and vertical control timing waveform

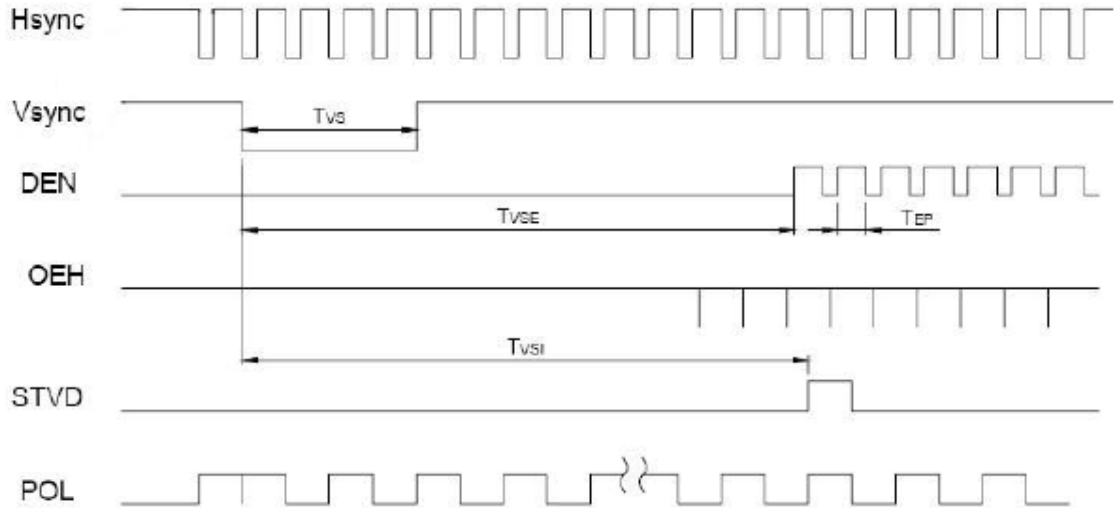

5.4-4 CCIR601 timing waveform

CCIR601 timing waveform (VS_POL = "H" _POL = "L" in Register R2)

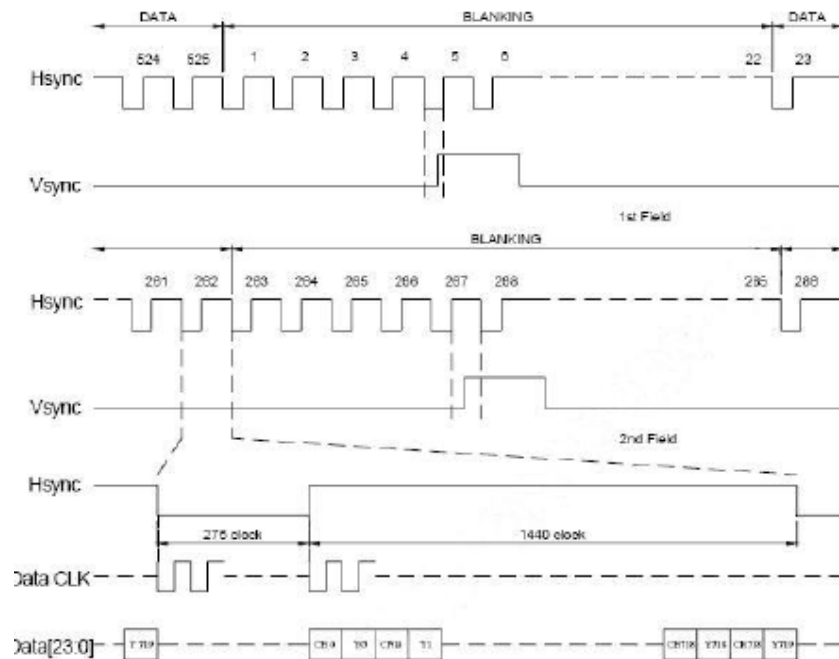

ITU-BT.601 NTSC Input Timing



Microtips Technology Inc.

Messrs.					
Product Specification	Model:	MTF-TQ35SN941-LB	Rev. No.	Issued Date.	Page.
			A	December.14,09	15 / 32

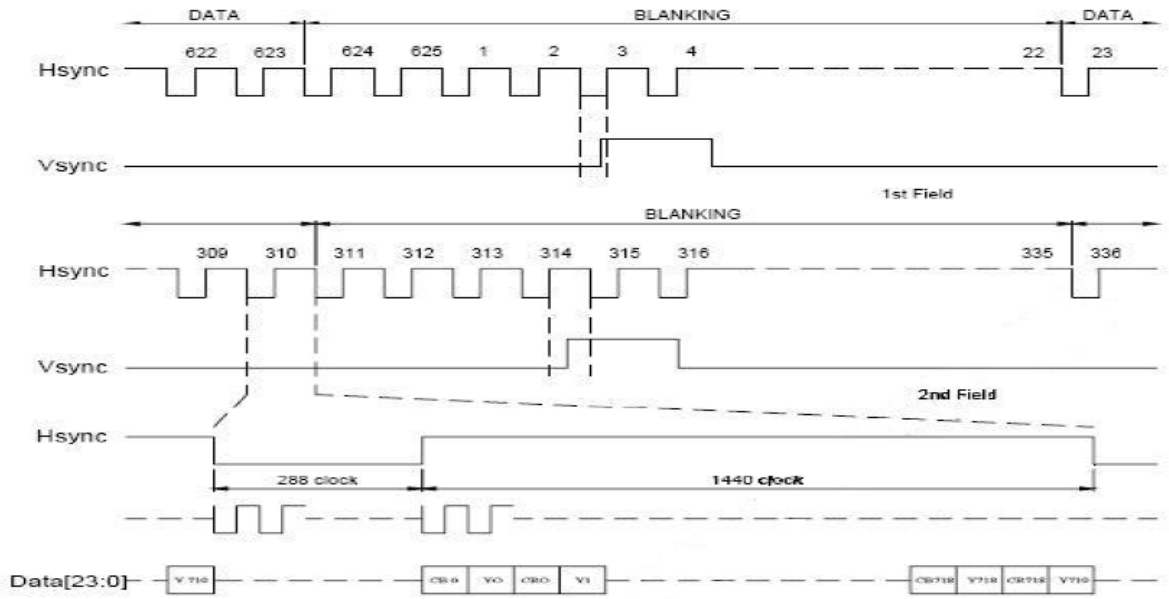

ITU-BT 601 PAL Input Timing



Microtips Technology Inc.

Messrs.					
Product Specification	Model:	MTF-TQ35SN941-LB	Rev. No.	Issued Date.	Page.
			A	December.14,09	16 / 32

5.4-5 Source Driver Timing Chart

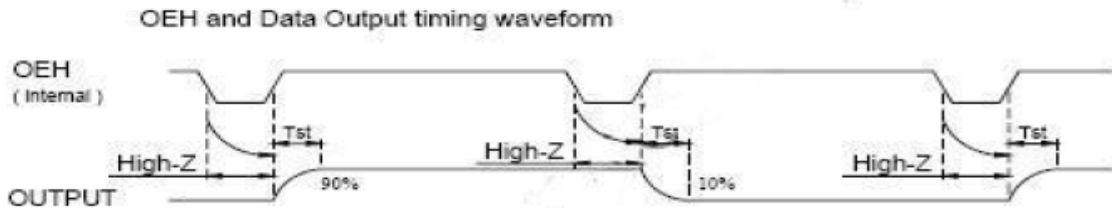
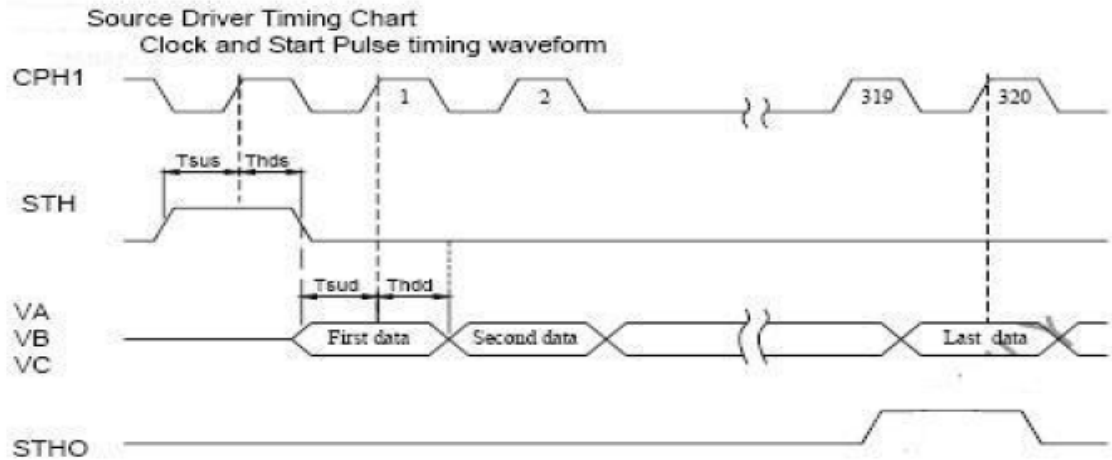

Analog video signal characteristics

PARAMETER	Symbol	Min.	Typ.	Max.	Unit
Video signal amplitude (VA, VB, VC)	V_{IAC}	-	3.81	-	V
	V_{IPC}	-	2.385	-	V

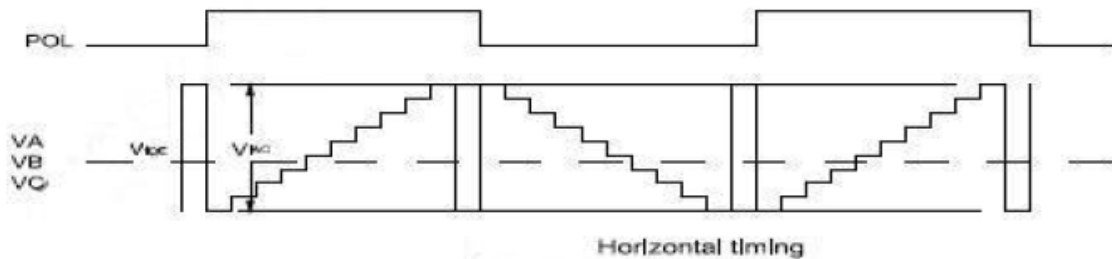

Microtips Technology Inc.

Messrs.					
Product Specification	Model:	MTF-TQ35SN941-LB	Rev. No.	Issued Date.	Page.
			A	December.14,09	17 / 32

5.4-6 Gate Driver Timing Chart

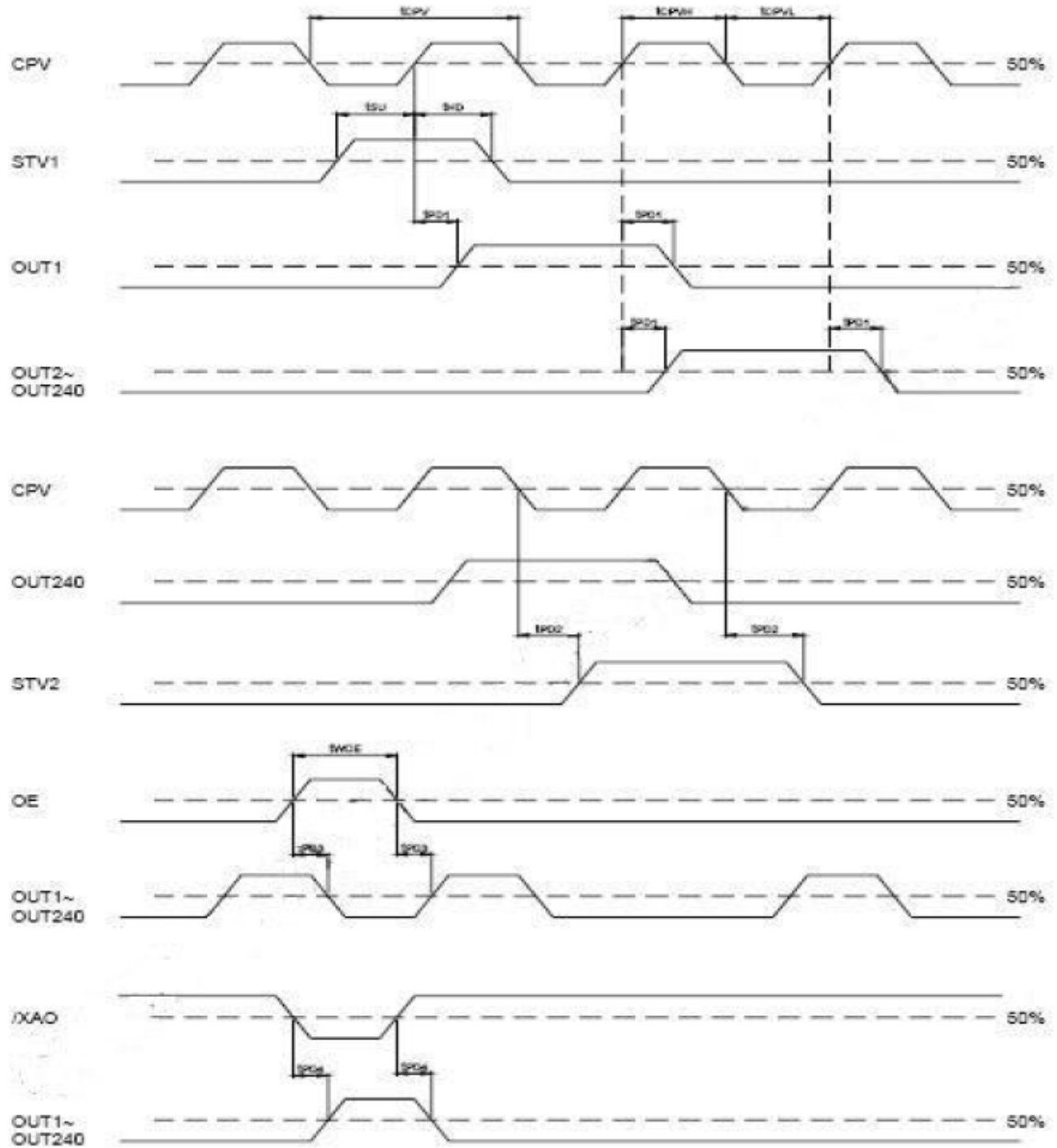

Microtips Technology Inc.

Messrs.					
Product Specification	Model:	MTF-TQ35SN941-LB	Rev. No.	Issued Date.	Page.
			A	December.14,09	18 / 32

6. OPTICAL CHARACTERISTICS

Ta=25±2°C, ILED = 20mA

Item		Symbol	Condition	Min	Type	Max	Unit	Remark
Response time	Rise	T _R	θ = 0	--	10	--	ms	Note 3, 5
	Fall	T _F	Φ = 0	--	15	--	ms	
Contrast ratio		CR	At optimized Viewing angle	300	400	--	--	Note 4, 5
Color Chromaticity	White	W _X	θ = 0 Φ = 0	0.26	0.31	0.36	--	Note 2, 6, 7
		W _Y		0.28	0.33	0.38		
	Red	R _X		--	--	--	--	
		R _Y		--	--	--		
	Green	G _X		--	--	--	--	
		G _Y		--	--	--		
	Blue	B _X		--	--	--	--	
		B _Y		--	--	--		
Viewing Angle	Hor.	θ _R	Center CR≥10	50	60	--	Degree	Note 1
		θ _L		50	60	--		
	Ver.	θ _T		40	50	--		
		θ _B		45	55	--		
Brightness		--	--	200	250	--	cd/m ²	Center of display

Note 1: Definition of viewing angle range

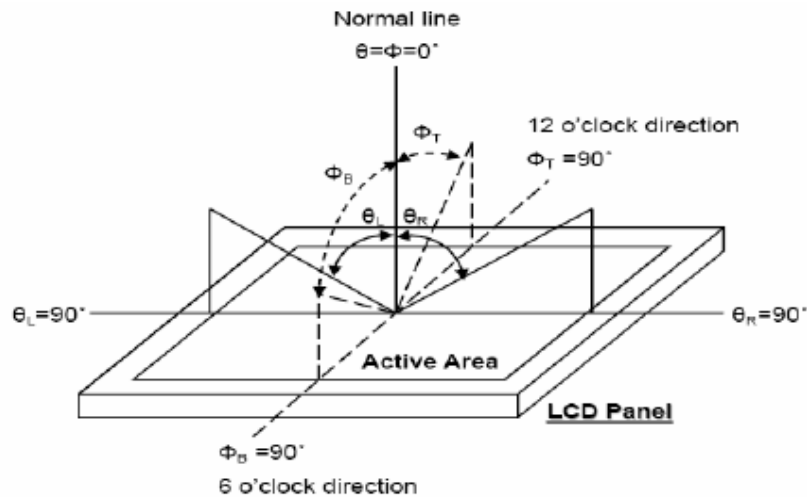

Fig. 8-1 Definition of viewing angle



Microtips Technology Inc.

Messrs.					
Product Specification	Model:	MTF-TQ35SN941-LB	Rev. No.	Issued Date.	Page.
			A	December.14,09	19 / 32

Note 2: Teat equipment setup:

After stabilizing and leaving the panel alone at a driven temperature for 10 minutes, the measurement should be executed. Measurement should be executed in a stable, windless, and dark room. Optical specifications are measured by Topcon BM-7 luminance meter 1.0° field of view at a distance of 50cm and normal direction.

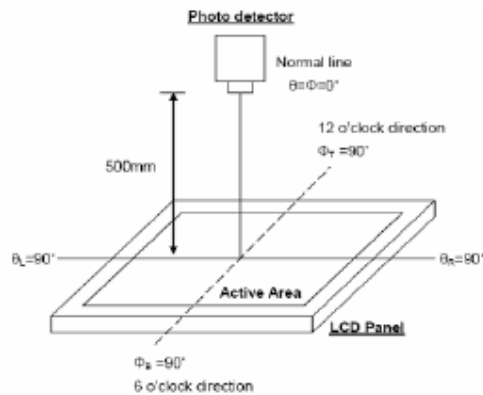

Fig. 8-2 Optical measurement system setup

Note 3: Definition of Response time:

The response time is defined as the LCD optical switching time interval between "White" state and "Black" state. Rise time, T_r , is the time between photo detector output intensity changed from 90% to 10%. And fall time, T_f , is the time between photo detector output intensity changed from 10% to 90%.

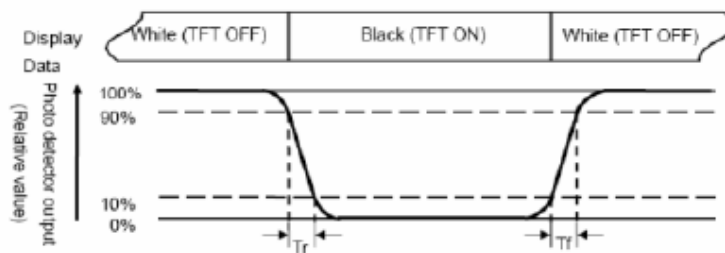

Fig. 3-3 Definition of response time

Note 4: Definition of contrast ratio:

The contrast ratio is defined as the following expression.

$$\text{Contrast ratio (CR)} = \frac{\text{Luminance measured when LCD on the "White" state}}{\text{Luminance measured when LCD on the "Black" state}}$$



Microtips Technology Inc.

Messrs.					
Product Specification	Model:	MTF-TQ35SN941-LB	Rev. No.	Issued Date.	Page.
			A	December.14,09	20 / 32

Note 5: White $V_i = V_{i50} \pm 1.5V$

Black $V_i = V_{i50} \pm 2.0V$

“±” means that the analog input signal swings in phase with VCOM signal.

“±” means that the analog input signal swings out of phase with VCOM signal.

The 100% transmission is defined as the transmission of LCD panel when all the input terminals of module are electrically opened.

Note 6: Definition of color chromaticity (CIE 1931)

Color coordinates measured at the center point of LCD

Note 7: Measured at the center area of the panel when all the input terminals of LCD panel are electrically opened.

Note 8:
$$\text{Uniformity (U)} = \frac{\text{Brightness (min)}}{\text{Brightness (max)}} \times 100\%$$



Microtips Technology Inc.

Messrs.					
Product Specification	Model:	MTF-TQ35SN941-LB	Rev. No.	Issued Date.	Page.
			A	December.14,09	21 / 32

7. INPUT TERMINAL PIN ASSIGNMENT

7.1 LCM PIN Definition

Pin No.	Symbol	I/O	Function	Remark
1.	VBL –	I	Backlight LED Ground	--
2.	VBL –	I	Backlight LED Ground	--
3.	VBL +	I	Backlight LED Power	--
4.	VBL +	I	Backlight LED Power	--
5.	Y1	--	Top Electrode	--
6.	X1	I	Right Electrode	--
7.	NC	--	Not Use	--
8.	/RESET	I	Hardware Reset	--
9.	SPENA	I	SPI Interface Data Enable Signal	Note 3
10.	SPCLK	I	SPI Interface Data Clock	Note 3
11.	SPDAT	I	SPI Interface Data	Note 3
12.	B0	I	Blue Data Bit 0	--
13.	B1	I	Blue Data Bit 1	--
14.	B2	I	Blue Data Bit 2	--
15.	B3	I	Blue Data Bit 3	--
16.	B4	I	Blue Data Bit 4	--
17.	B5	I	Blue Data Bit 5	--
18.	B6	I	Blue Data Bit 6	--
19.	B7	I	Blue Data Bit 7	--
20.	G0	I	Green Data Bit0	--
21.	G1	I	Green Data Bit1	--
22.	G2	I	Green Data Bit2	--
23.	G3	I	Green Data Bit3	--
24.	G4	I	Green Data Bit4	--
25.	G5	I	Green Data Bit5	--
26.	G6	I	Green Data Bit6	--
27.	G7	I	Green Data Bit7	--
28.	R0	I	Red Data Bit0 / DX0	Note 4
29.	R1	I	Red Data Bit1 / DX1	Note 4
30.	R2	I	Red Data Bit2 / DX2	Note 4



Microtips Technology Inc.

Messrs.					
Product Specification	Model:	MTF-TQ35SN941-LB	Rev. No.	Issued Date.	Page.
			A	December.14,09	22 / 32

Pin No.	Symbol	I/O	Function	Remark
31.	R3	I	Red Data Bit3 / DX3	Note 4
32.	R4	I	Red Data Bit4 / DX4	Note 4
33.	R5	I	Red Data Bit5 / DX5	Note 4
34.	R6	I	Red Data Bit6 / DX6	Note 4
35.	R7	I	Red Data Bit7 / DX7	Note 4
36.	H _{SYNC}	I	Horizontal Sync Input	--
37.	V _{SYNC}	I	Vertical Sync Input	--
38.	D _{CLK}	I	Dot Data Clock	--
39.	NC	--	Not Use	--
40.	NC	--	Not Use	--
41.	V _{CC}	I	Digital Power	--
42.	V _{CC}	I	Digital Power	--
43.	Y2	I	Bottom Electrode	--
44.	X2	I	Left Electrode	--
45.	NC	--	Internal test use	--
46.	NC	--	Not Use	--
47.	NC	--	Internal test use	--
48.	IF2	I	Control the input data format / floating	Note 1
49.	IF1	I	Control the input data format	Note 1, 5
50.	IF0	I	Control the input data format	Note 1, 5
51.	N/C	--	Not Use	--
52.	DE	I	Data Enable Input	Note 2
53.	GND	I	Ground	--
54.	GND	I	Ground	--

Note:

1. The mode control (IF2) not use ,it can't control CCIR601 interface , If not use CCIR601 ,it can floating.
2. For digital RGB input data format, both SYNC mode and DE+SYNC mode are supported. If DE signal is fixed low, SYNC mode is used. Otherwise, DE+SYNC mode is used.Suggest used SYNC mode!!
3. usually pull high.
4. IF select serial RGB or CCIR601/656 input mode is selected,only DX0-DX7 used,and the other short to GND, Only selected serial RGB · CCIR601/656 interface,DX BUS will enable,Digital input mode DX0 is LSB and DX7 is MSB.



Microtips Technology Inc.

Messrs.					
Product Specification	Model:	MTF-TQ35SN941-LB	Rev. No.	Issued Date.	Page.
			A	December.14,09	23 / 32

5. Control the input data format

IF2-0: Define the input interface mode.

IF2	IF1	IF0	Format	Operating Frequency
0	0	0	Parallel-RGB data format (only support stripe type color filter)	6.5MHz
0	0	1	Serial-RGB data format	19.5MHz
0	1	0	CCIR 656 data format (640RGB)	24.54MHz
0	1	1	CCIR 656 data format (720RGB)	27MHz
1	0	0	YUV mode A data format (Cr-Y-Cb-Y)	24.54MHz
1	0	1	YUV mode A data format (Cr-Y-Cb-Y)	27MHz
1	1	0	YUV mode B data format (Cb-Y-Cr-Y)	27MHz
1	1	1	YUV mode B data format (Cb-Y-Cr-Y)	24.54MHz

Input format	DOTCLK Freq (MHz)	Display Data	Active Area (DOTCLK)
YUV mode	24.54	640	1280
	27	720	1440

Mode	D[23:16]	D[15:8]	D[7:0]	IHS	IVS	DEN
ITU-R BT 656	D[23:16]	GND	GND	NC	NC	NC
ITU-R BT 601	D[23:16]	GND	GND	IHS	IVS	NC
8 bit RGB	D[23:16]	GND	GND	IHS	IVS	NC for HV Mode DEN for DEN Mode
24 bit RGB	R[7:0]	G[7:0]	B[7:0]	IHS	IVS	NC for HV Mode DEN for DEN Mode

7.2 SPI Timing Characteristics

PARAMETER	Symbol	Min.	Typ.	Max.	Unit
SPCK period	T_{CK}	60	-	-	ns
SPCK high width	T_{CKH}	30	-	-	ns
SPCK low width	T_{CKL}	30	-	-	ns
Data setup time	T_{SU1}	12	-	-	ns
Data hold time	T_{HD1}	12	-	-	ns
SPENA to SPCK setup time	T_{CS}	20	-	-	ns
SPENA to SPDA hold time	T_{CO}	20	-	-	ns
SPENA high pulse width	T_{CH}	50	-	-	ns
SPDA output latency	T_{OL}	-	1/2	-	T_{CK}

• SPI read timing

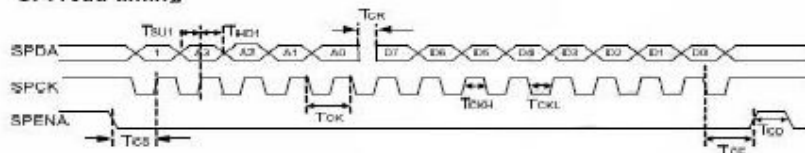

Figure8 SPI read timing

• SPI write timing

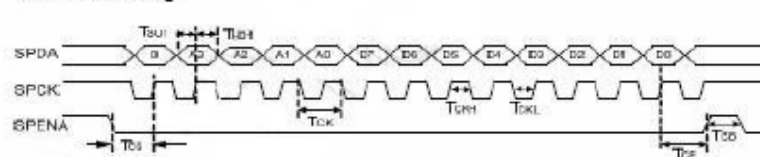

Figure9 SPI write timing



Microtips Technology Inc.

Messrs.					
Product Specification	Model:	MTF-TQ35SN941-LB	Rev. No.	Issued Date.	Page.
			A	December.14,09	24 / 32

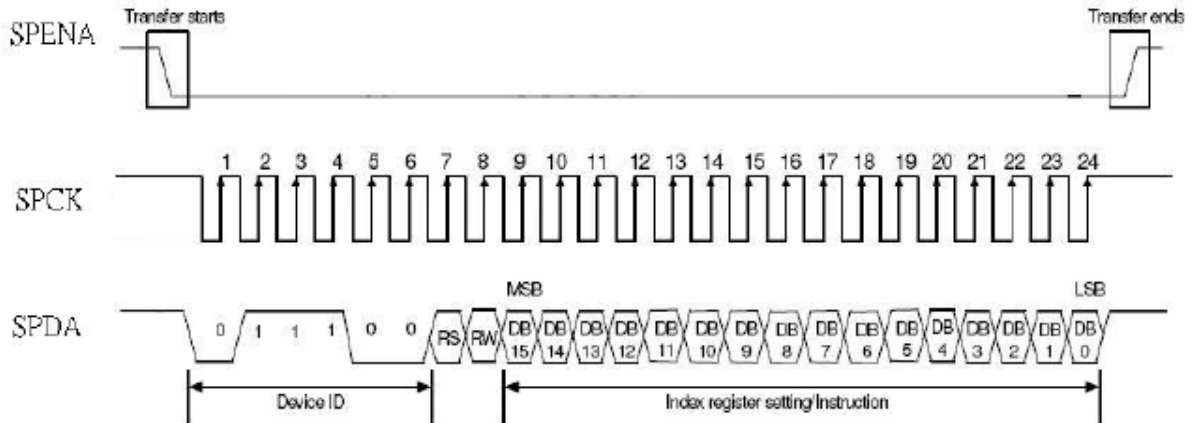

Figure10 SPI timing

7.3 SPI Register Description

Will be showing on Application Note From Chilintech.



Microtips Technology Inc.

Messrs.					
Product Specification	Model:	MTF-TQ35SN941-LB	Rev. No.	Issued Date.	Page.
			A	December.14,09	25 / 32

8. BASIC DISPLAY COLOR AND GRAY SCALE

Color		Input Color Data																							
		Red								Green						Blue									
		MSB				LSB				MSB			LSB			MSB		LSB							
		R7	R6	R5	R4	R3	R2	R1	R0	G7	G6	G5	G4	G3	G2	G1	G0	B7	B6	B5	B4	B3	B2	B1	B0
Basic Colors	Black	0	0	0	0	0	0	0	0	0	0	0	0	0	0	0	0	0	0	0	0	0	0	0	0
	Red(255)	1	1	1	1	1	1	1	1	0	0	0	0	0	0	0	0	0	0	0	0	0	0	0	0
	Green(255)	0	0	0	0	0	0	0	0	1	1	1	1	1	1	1	1	0	0	0	0	0	0	0	0
	Blue(255)	0	0	0	0	0	0	0	0	0	0	0	0	0	0	0	0	1	1	1	1	1	1	1	1
	Cyan	0	0	0	0	0	0	0	0	1	1	1	1	1	1	1	1	1	1	1	1	1	1	1	1
	Magenta	1	1	1	1	1	1	1	1	0	0	0	0	0	0	0	0	1	1	1	1	1	1	1	1
	Yellow	1	1	1	1	1	1	1	1	1	1	1	1	1	1	1	1	0	0	0	0	0	0	0	0
	White	1	1	1	1	1	1	1	1	1	1	1	1	1	1	1	1	1	1	1	1	1	1	1	1
Red	Red(0) Dark	0	0	0	0	0	0	0	0	0	0	0	0	0	0	0	0	0	0	0	0	0	0	0	0
	Red(1)	0	0	0	0	0	0	0	1	0	0	0	0	0	0	0	0	0	0	0	0	0	0	0	0
	Red(2)	0	0	0	0	0	0	1	0	0	0	0	0	0	0	0	0	0	0	0	0	0	0	0	0
	:	:	:	:	:	:	:	:	:	:	:	:	:	:	:	:	:	:	:	:	:	:	:	:	:
	Red(253)	1	1	1	1	1	1	0	1	0	0	0	0	0	0	0	0	0	0	0	0	0	0	0	0
	Red(254)	1	1	1	1	1	1	1	0	0	0	0	0	0	0	0	0	0	0	0	0	0	0	0	0
	Red(255) Bright	1	1	1	1	1	1	1	1	0	0	0	0	0	0	0	0	0	0	0	0	0	0	0	0
	Green	Green(0) Dark	0	0	0	0	0	0	0	0	0	0	0	0	0	0	0	0	0	0	0	0	0	0	0
Green(1)		0	0	0	0	0	0	0	0	0	0	0	0	0	0	0	1	0	0	0	0	0	0	0	0
Green(2)		0	0	0	0	0	0	0	0	0	0	0	0	0	0	1	0	0	0	0	0	0	0	0	0
:		:	:	:	:	:	:	:	:	:	:	:	:	:	:	:	:	:	:	:	:	:	:	:	:
Green(253)		0	0	0	0	0	0	0	0	1	1	1	1	1	1	0	1	0	0	0	0	0	0	0	0
Green(254)		0	0	0	0	0	0	0	0	1	1	1	1	1	1	1	0	0	0	0	0	0	0	0	0
Green(255)Bright		0	0	0	0	0	0	0	0	1	1	1	1	1	1	1	1	0	0	0	0	0	0	0	0
Blue	Blue(0) Dark	0	0	0	0	0	0	0	0	0	0	0	0	0	0	0	0	0	0	0	0	0	0	0	0
	Blue(1)	0	0	0	0	0	0	0	0	0	0	0	0	0	0	0	0	0	0	0	0	0	0	0	1
	Blue(2)	0	0	0	0	0	0	0	0	0	0	0	0	0	0	0	0	0	0	0	0	0	0	1	0
	:	:	:	:	:	:	:	:	:	:	:	:	:	:	:	:	:	:	:	:	:	:	:	:	:
	Blue(253)	0	0	0	0	0	0	0	0	0	0	0	0	0	0	0	0	1	1	1	1	1	1	0	1
	Blue(254)	0	0	0	0	0	0	0	0	0	0	0	0	0	0	0	0	1	1	1	1	1	1	1	0
	Blue(255) Bright	0	0	0	0	0	0	0	0	0	0	0	0	0	0	0	0	1	1	1	1	1	1	1	1



Microtips Technology Inc.

Messrs.					
Product Specification	Model:	MTF-TQ35SN941-LB	Rev. No.	Issued Date.	Page.
			A	December.14,09	26 / 32

9. BLOCK DIAGRAM

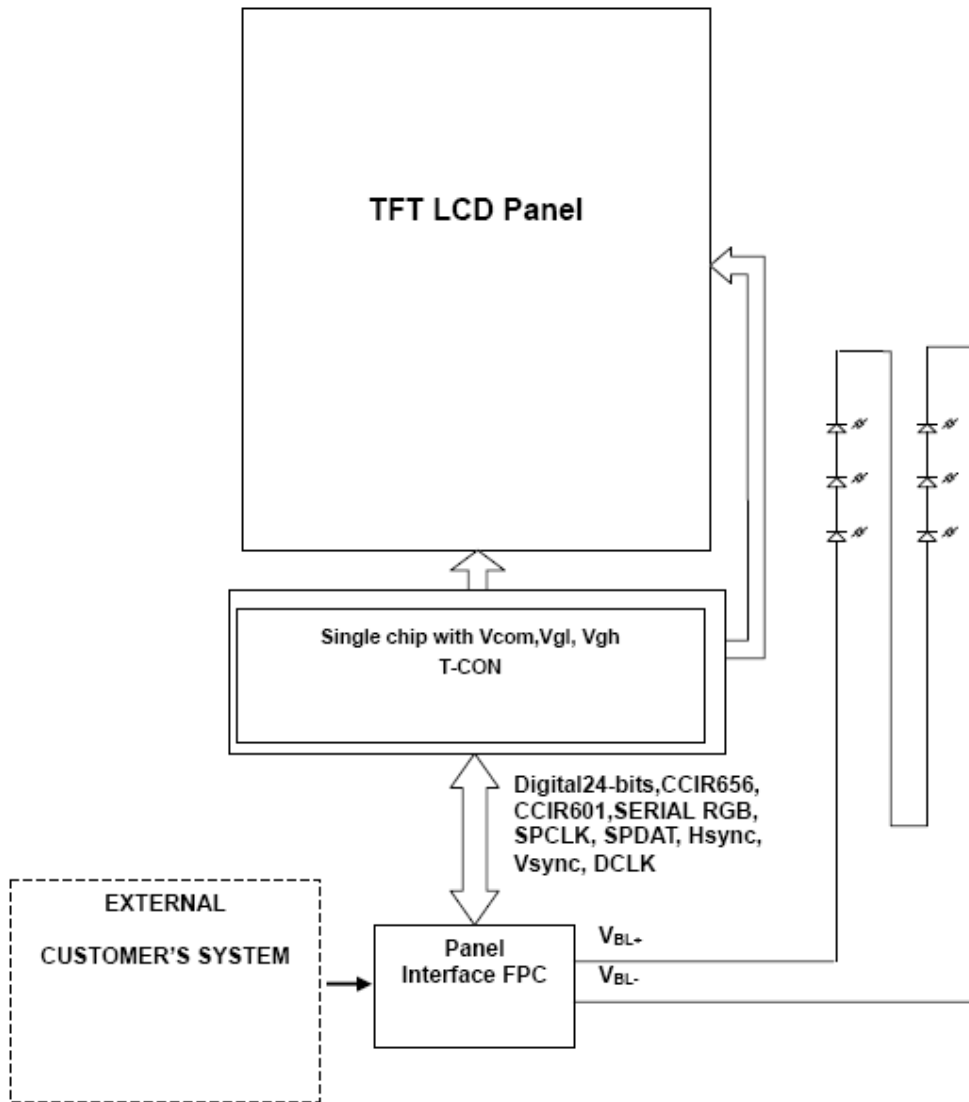

Microtips Technology Inc.

Messrs.					
Product Specification	Model:	MTF-TQ35SN941-LB	Rev. No.	Issued Date.	Page.
			A	December.14,09	27 / 32

10. QUALITY ASSURANCE

No.	Item	Test Condition	Remark
1.	High Temperature Storage Test.	80°C 240 Hrs	--
2.	Low Temperature Storage Test.	-30°C 240 Hrs	--
3.	High Temperature Operating Test.	70°C 240 Hrs	--
4.	Low Temperature Operating Test.	-20°C 240 Hrs	--
5.	High Temperature and High Humidity Operating Test	Ta = 60°C 90% RH 240 Hrs	--
6.	Electro Static Discharge Test.	Panel surface / top case. Contact / Air:±6KV / ±8KV, 150pF , 330Ω	Non – Operating
7.	Shock Test Non – Operating	Shock Level: 100G Waveform: Half Sinusoidal Wave Shock Time: 6ms Number of Shocks: 3times for each ±X, ±Y, ±Z direction	--
8.	Vibration Test Non – Operating	Frequency range: 10Hz ~ 550Hz Stoke: 1.3mm Sweep: 1.5G, 33.3 ~ 400Hz Vibration: Sinusoidal Wave, 1Hrs for X, Y, Z direction	--
9.	Thermal Shock	-20°C (0.5h) ~ 70°C (0.5h) 100 cycles	--

*** Ta = Ambient Temperature

Note:

1. The test samples have recovery time for 2 hours at room temperature before the function check. In the standard conditions, there is no display function NG issue occurred.
2. All the cosmetic specifications are judged before the reliability stress.



Microtips Technology Inc.

Messrs.					
Product Specification	Model:	MTF-TQ35SN941-LB	Rev. No.	Issued Date.	Page.
			A	December.14,09	28 / 32

11. PRECAUTIONS





11.1 Operation

Burn-in sometimes happens when the same character was displayed at along time. Therefore, to prevent Burn-in, it is recommended to set up a Screen-saver function.

11.2 Safety

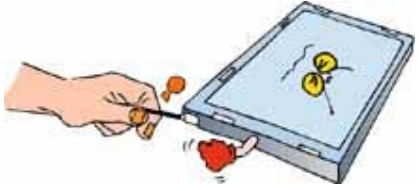
The liquid crystal in the LCD is poisonous, DO NOT put it in your mouth. If the liquid crystal touch es your skin or clothes, wash it off immediately using soap and water.



11.3 Handling

	<p>a. The LCD module shall be installed flat, without twisting or bending. b. COF or FPC has narrow pattern width, so easily become open circuit by external force. DO NOT apply pressure to COF or FPC especially in bending area.</p>
	<p>c. To avoid damage in appearance or malfunction, DO NOT subject the module to mechanical shock or to excessive force on its surface.</p>
	<p>d. The polarizer attached to the display is very easy to damage, handle it with care to avoid scratching.</p>
	<p>e. To avoid contamination on the display surface, DO NOT touch the display surface with bare hands. f. Provide a space so that the LCD module does not come into contact with other components.</p>



Microtips Technology Inc.

Messrs.					
Product Specification	Model:	MTF-TQ35SN941-LB	Rev. No.	Issued Date.	Page.
			A	December.14,09	29 / 32

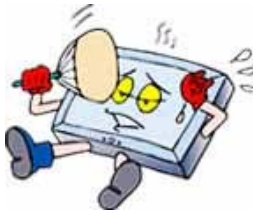
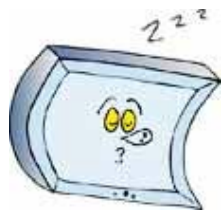
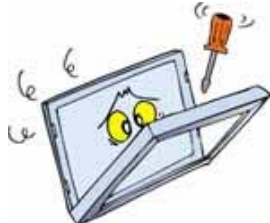
	<p>g. To protect the LCD panel from external pressure, put covering glass (acrylic board or similar board) to keep appropriate space between them.</p>
	<p>h. Be careful for condensation at sudden temperature change. Condensation makes damage to polarizer or electrical contacted parts. And after fading condensation, smear or spot will occur.</p>
	<p>i. Property of semiconductor devices may be affected when they are exposed to light possibly resulting in malfunctioning of the ICs. To prevent such malfunctioning of the ICs, your design and mounting layout done are so that the IC is not exposed to light in actual use.</p>
	<p>j. Strong light exposure causes degradation of color filter. It may not recover</p>
	<p>k. DO NOT contact with water to avoid Metal corrosion. l. When it is not in use, the screen must be turned off or the pattern must be frequently changed by a screen saver. If it displays the same pattern for a long period of time, brightness down/image sticking may develop due to the LCD structure.</p>
	<p>m. Never disassemble LCD product under any circumstances. If unqualified operators or users assemble the product after disassembling it, it may not function or its operation may be seriously affected.</p>



Microtips Technology Inc.

Messrs.					
Product Specification	Model:	MTF-TQ35SN941-LB	Rev. No.	Issued Date.	Page.
			A	December.14,09	30 / 32

11.4 Static electricity

Since a module is composed of electronic circuits, it is not strong to electrostatic discharge.

	<ol style="list-style-type: none"> The LCD module shall be installed flat, without twisting or bending. Ground soldering iron tips, tools and testers when they operate. Ground your body when handling the products. DO NOT apply voltage to the input terminal without applying power supply. DO NOT apply voltage that exceeds the absolute maximum rating. Store the products in an anti-electrostatic container. Peel off protect tape, attached to polarizer, slowly to minimize ESD damage.
---	--

11.5 Storage

	<p>Store the products in a dark place at +5 ~ +25 degree C, low humidity (50%RH or less). DO NOT store the products in an atmosphere containing organic solvents or corrosive gases.</p>
---	--

11.6 Cleaning

	<ol style="list-style-type: none"> DO NOT wipe the polarizer with dry cloth, as it might cause scratch. Wipe the polarizer with a soft cloth soaked with petroleum IPA, other chemical might damage.
---	--

11.7 Waste

	<p>When dispose of LCD module, manage it at the production waste according to the relevant laws and regulations.</p>
---	--



Microtips Technology Inc.

Messrs.					
Product Specification	Model:	MTF-TQ35SN941-LB	Rev. No.	Issued Date.	Page.
			A	December.14,09	31 / 32

12. WARRANTY

This product has been manufactured to your company's specifications as a part for use in your company's general electronic products. It is guaranteed to perform according to delivery specifications. For any other use apart from general electronic equipment, we cannot take responsibility if the product is used in medical devices, nuclear power control equipment, aerospace equipment, fire and security systems, or any other applications in which there is a direct risk to human life and where extremely high levels of reliability are required. If the product is to be used in any of the above applications, we will need to enter into a separate product liability agreement.

- 1 13 months guarantee starts from the date code.
- 2 We cannot accept responsibility for any defect, which may arise from additional manufacturing of the product (including disassembly and reassembly), after product delivery.
- 3 We cannot accept responsibility for any defect, which may arise after the application of strong external force to the product.
- 4 We cannot accept responsibility for any defect, which may arise due to the application of static electricity after the product has passed your company's acceptance inspection procedures.
- 5 We cannot accept responsibility for industrial property, which may arise through the use of your product, with exception to those issues relating directly to the structure or method of manufacturing of our product. Microtips-origin longer than one year from Microtips production.

13. DIMENSIONAL OUTLINES

See Next page.....



Microtips Technology Inc.

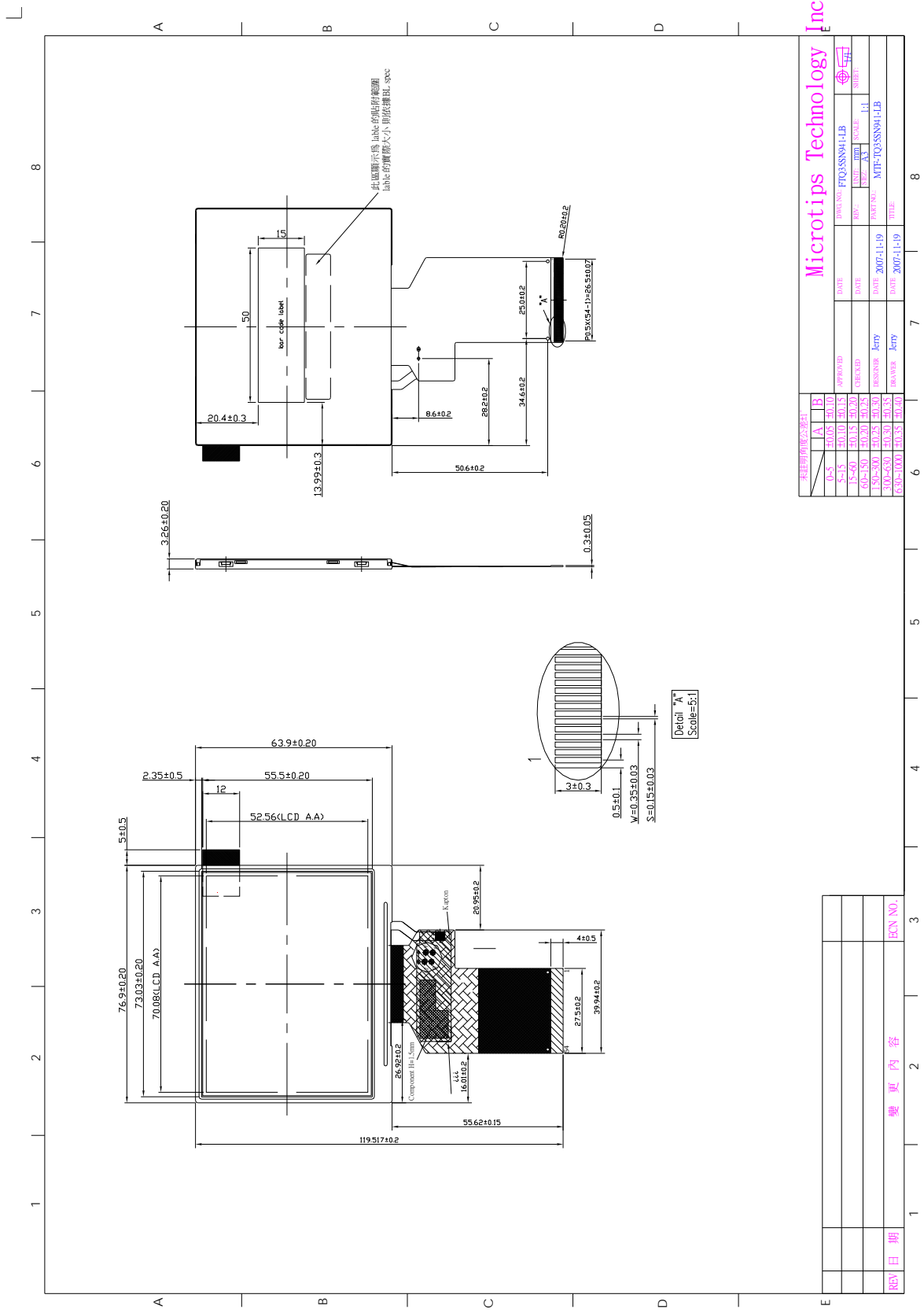

Microtips Technology Inc.

REV	日期	變更內容	ECN NO.
1			
2			
3			
4			
5			
6			
7			
8			

REV	日期	變更內容	ECN NO.
1			
2			
3			
4			
5			
6			
7			
8			

REV	日期	變更內容	ECN NO.
1			
2			
3			
4			
5			
6			
7			
8			

Microtips Technology Inc.