

Aluminum Capacitors Power Eurodin Screw Terminals

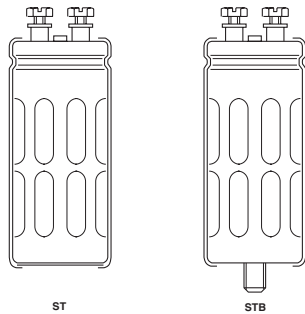

Fig. 1 Component outlines.



FEATURES

- Polarized aluminum electrolytic capacitors, non-solid electrolyte
- Large types, cylindrical aluminum case, insulated with a blue sleeve
- Also available in bolt version (114/115 PED-STB)
- Pressure relief in the sealing
- Charge and discharge proof
- Extremely low ESR and ESL allowing very high ripple current load, achieved by a special construction with multiple internal anode and cathode connections
- Very long useful life: 20000 hours at 85 °C
- High resistance to shock and vibration achieved by longitudinal rills and special internal construction.



APPLICATIONS

- Computer, telecommunications and industrial systems
- Smoothing and filtering
- Standard and switched mode power supplies
- Energy storage in pulse systems.

MARKING

The capacitors are marked with the following information:

- Rated capacitance (in μF).
- Tolerance on rated capacitance, code letter in accordance with IEC 60062 (Q for -10/+30%).
- Rated voltage (in V).
- Date code (YYMM).
- Name of manufacturer.
- Code for factory of origin.
- Code number.
- Climatic category in accordance with IEC 60068.
- "LL" for long life grade.

QUICK REFERENCE DATA		
DESCRIPTION	Value	
	114	115
Nominal case size ($\varnothing D \times L$ in mm)	35 × 60 to 75 × 105	
Rated capacitance range (E6 series), C_R	150 to 220000 μF	
Tolerance on C_R	-10 to +30%	
Rated voltage range, U_R	10 to 100V	250 to 400V
Category temperature range	-40 to +85 °C	
Endurance test at 85 °C	8000 hours (400 V: 5000 hours)	
Useful life at 85 °C	20000 hours (400 V: 12000 hours)	
Useful life at 40 °C, $1.4 \times I_R$ applied	350000 hours (400 V: 220000 hours)	
Shelf life at 0 V, 85 °C	500 hours	
Based on sectional specification	IEC 60384-4/EN130300	
Climatic category IEC 60068	40/085/56	

SELECTION CHART FOR C_R , U_R AND RELEVANT NOMINAL CASE SIZES ($\varnothing D \times L$ in mm) for 114 PED-ST series						
C_R (μF)	U_R (V)					
	10	16	25	40	63	100
1000	-	-	-	-	-	35 × 60
1500	-	-	-	-	-	35 × 60
2200	-	-	-	-	35 × 60	35 × 80
3300	-	-	-	35 × 60	35 × 60	35 × 105
4700	-	-	35 × 60	35 × 60	35 × 80	50 × 80
6800	-	-	35 × 60	35 × 80	35 × 105	50 × 105
10000	-	35 × 60	35 × 80	35 × 105	50 × 80	65 × 105
15000	35 × 60	35 × 80	35 × 105	50 × 80	50 × 105	65 × 105
22000	35 × 80	35 × 105	50 × 80	50 × 105	65 × 105	75 × 105
33000	35 × 105	50 × 80	50 × 105	65 × 105	65 × 105	-
47000	50 × 80	50 × 105	65 × 105	65 × 105	75 × 105	-
68000	50 × 105	65 × 105	65 × 105	75 × 105	-	-
100000	65 × 105	65 × 105	75 × 105	-	-	-
150000	65 × 105	75 × 105	-	-	-	-
220000	75 × 105	-	-	-	-	-

SELECTION CHART FOR C_R, U_R AND RELEVANT NOMINAL CASE SIZES ($\varnothing D \times L$ in mm) for 115 PED-ST series				
C_R (μF)	U_R (V)			
	250	350	385	400
150	–	–	35 × 60	35 × 60
220	–	35 × 60	35 × 80	35 × 80
330	35 × 60	35 × 80	35 × 105	35 × 105
470	35 × 80	35 × 105	50 × 80	50 × 80
680	35 × 105	50 × 80	50 × 105	50 × 105
1000	50 × 80	50 × 105	65 × 105	65 × 105
1500	50 × 105	65 × 105	65 × 105	65 × 105
2200	65 × 105	65 × 105	75 × 105	75 × 105
3300	65 × 105	75 × 105	–	–
4700	75 × 105	–	–	–

DIMENSIONS in millimeters AND AVAILABLE FORMS

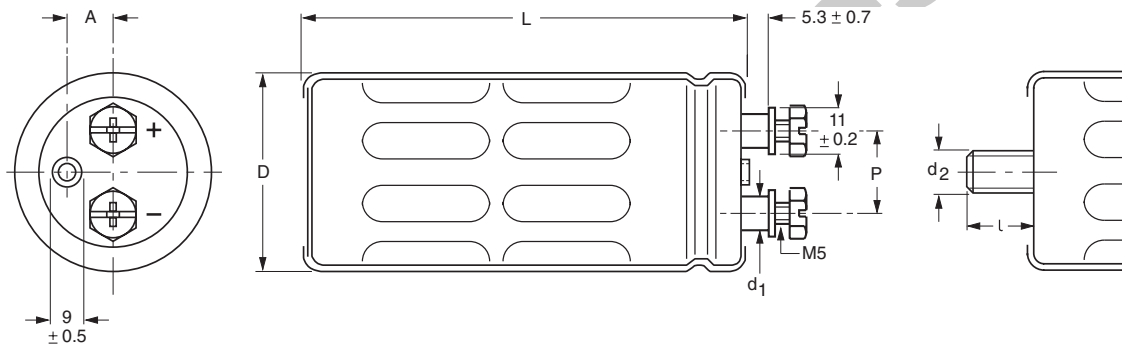

Maximum permissible torque which may be applied to the termination screws: 2 Nm.
For accessories refer to data sheet "Mounting Accessories".
The capacitors are delivered with screws and washers.

Fig.2 Screw terminal (ST); screw terminal bolt (STB).

Table 1

DIMENSIONS in millimeters, MASS AND PACKAGING QUANTITIES									
NOMINAL CASE SIZE $\varnothing D \times L$	$\varnothing D_{max}$	L_{max}	P ± 0.1	A	d_1 ± 0.2	$d_2 \times l$	MASS (g)	PACKAGING QUANTITIES (per box)	CARDBOARD BOX DIMENSIONS $L \times W \times H$
35 × 60	36.5	63	13.0	8.4	8.0	M8 × 12	≈55	25	196 × 192 × 110
35 × 80	36.5	83	13.0	8.4	8.0	M8 × 12	≈80	25	196 × 192 × 115
35 × 105	36.5	108	13.0	8.4	8.0	M8 × 12	≈110	25	196 × 192 × 140
50 × 80	51.5	83	22.0	14.3	8.0	M12 × 16	≈160	25	293 × 273 × 115
50 × 105	51.5	108	22.0	14.3	8.0	M12 × 16	≈210	25	293 × 273 × 140
65 × 105	66.5	108	28.5	19.0	9.6	M12 × 16	≈370	10	368 × 151 × 140
75 × 105	76.5	108	32.0	21.0	9.6	M12 × 16	≈535	10	418 × 173 × 140



ELECTRICAL DATA	
SYMBOL	DESCRIPTION
C _R	rated capacitance at 100 Hz, tolerance -10 to +30%
I _R	rated RMS ripple current at 100 Hz, 85 °C
I _{L5}	max. leakage current after 5 minutes at U _R
ESR	typical equivalent series resistance at 100 Hz
Z	impedance at 20 kHz
Tan δ	max. dissipation factor at 100 Hz

ORDERING EXAMPLE

Electrolytic capacitor 114 PED-ST series
10000 µF/25 V; -10/+30%
Nominal case size: Ø35 × 80 mm; ST version
Catalog number: 2222 114 16103.

Note

- Unless otherwise specified, all electrical values in Tables and apply at T_{amb} = 20 °C, P = 86 to 106 kPa, RH = 45 to 75%.

Table 2

ELECTRICAL DATA AND ORDERING INFORMATION FOR THE 114 PED-ST SERIES									
U _R (V)	C _R 100 Hz (µF)	NOMINAL CASE SIZE ØD × L (mm)	I _R 100 Hz 85 °C (A)	I _{L5} 5 min (mA)	ESR TYP. 100 Hz (mΩ)	Tan δ MAX. 100 Hz	Z TYP. 20 kHz (mΩ)	Z MAX. 20 kHz (mΩ)	CATALOG NUMBER (see Table 3, note 1) 2222 114
10	15000	35 × 60	6	0.30	20	0.32	13	20	14153
	22000	35 × 80	7.5	0.43	14	0.33	9.5	14	14223
	33000	35 × 105	10	0.66	10	0.35	7.5	10	14333
	47000	50 × 80	14	0.94	7.5	0.36	5.0	9.5	14473
	68000	50 × 105	18	1.36	5.5	0.38	4.0	8.0	14683
	100000	65 × 105	30	2.00	3.5	0.34	3.0	5.0	14104
	150000	65 × 105	30	3.00	3.0	0.45	3.0	5.0	14154
	220000	75 × 105	37	4.40	2.0	0.45	2.5	4.0	14224
16	10000	35 × 60	6	0.32	22	0.22	13	20	15103
	15000	35 × 80	7.5	0.40	15	0.23	9.5	14	15153
	22000	35 × 105	10	0.71	11	0.25	7.0	10	15223
	33000	50 × 80	13	1.06	7.5	0.26	5.0	9.5	15333
	47000	50 × 105	18	1.51	5.5	0.27	4.0	8.0	15473
	68000	65 × 105	28	2.18	3.5	0.24	3.0	5.0	15683
	100000	65 × 105	28	3.20	3.0	0.31	3.0	5.0	15104
	150000	75 × 105	37	4.80	2.0	0.31	2.5	4.0	15154
25	4700	35 × 60	5.2	0.24	30	0.14	15	23	16472
	6800	35 × 60	5.2	0.34	25	0.18	14	21	16682
	10000	35 × 80	6.7	0.50	18	0.18	10	15	16103
	15000	35 × 105	9.7	0.75	12	0.19	7.5	11	16153
	22000	50 × 80	12.5	1.10	8.5	0.19	5.5	9.5	16223
	33000	50 × 105	18	1.65	6.0	0.21	4.0	8.0	16333
	47000	65 × 105	27	2.35	4.0	0.18	3.0	5.0	16473
	68000	65 × 105	27	3.40	3.5	0.23	3.0	5.0	16683
100000	75 × 105	37	5.0	2.5	0.23	2.5	4.0	16104	
40	3300	35 × 60	4.5	0.27	37	0.13	21	32	17332
	4700	35 × 60	4.5	0.38	35	0.17	22	33	17472
	6800	35 × 80	6	0.55	25	0.17	15	23	17682
	10000	35 × 105	7.5	0.80	17	0.18	11	17	17103
	15000	50 × 80	10	1.20	11	0.17	7.5	13	17153
	22000	50 × 105	15	1.76	8.0	0.18	5.5	10.5	17223
	33000	65 × 105	21	2.64	5.0	0.16	3.5	6.0	17333
	47000	65 × 105	22	3.76	4.5	0.21	3.5	6.0	17473
68000	75 × 105	30	5.44	3.0	0.21	3.0	4.5	17683	
63	2200	35 × 60	3.7	0.28	39	0.09	22	33	18222
	3300	35 × 60	3.7	0.42	32	0.11	20	30	18332
	4700	35 × 80	5.2	0.66	23	0.11	14	21	18472
	6800	35 × 105	7.5	0.86	17	0.11	10	15	18682
	10000	50 × 80	9.5	1.26	12	0.12	7.5	14	18103
	15000	50 × 105	13.5	1.89	8.5	0.13	5.5	10.5	18153
	22000	65 × 105	21	2.77	5.0	0.11	3.5	6.0	18223
	33000	65 × 105	22	4.16	4.5	0.14	3.5	6.0	18333
47000	75 × 105	30	5.92	3.0	0.14	3.0	4.5	18473	
100	1000	35 × 60	3.0	0.20	85	0.09	45	67	19102
	1500	35 × 60	3.3	0.30	65	0.10	40	60	19152
	2200	35 × 80	4.6	0.41	45	0.10	28	42	19222
	3300	35 × 105	6.5	0.66	30	0.10	19	28	19332
	4700	50 × 80	7.4	0.94	27	0.11	17	25	19472
	6800	50 × 105	9.9	1.36	19	0.11	12	18	19682
	10000	65 × 105	15.0	2.00	11	0.11	7	11	19103
	15000	65 × 105	15.8	3.00	10	0.12	6	10	19153
22000	75 × 105	20.5	4.40	7	0.12	5	8	19223	

Table 3

ELECTRICAL DATA AND ORDERING INFORMATION FOR THE 115 PED-ST SERIES									
U_R (V)	C_R 100 Hz (μ F)	NOMINAL CASE SIZE $\varnothing D \times L$ (mm)	I_R 100 Hz 85 °C (A)	I_{L5} 5 min (mA)	ESR TYP. 100 Hz (m Ω)	Tan δ MAX. 100 Hz	Z TYP. 20 kHz (m Ω)	Z MAX. 20 kHz (m Ω)	CATALOG NUMBER (see note 1) 2222 115
250	330	35 × 60	1.8	0.17	300	0.15	275	500	13331
	470	35 × 80	2.5	0.24	250	0.15	140	375	13471
	680	35 × 105	3.5	0.34	180	0.15	125	300	13681
	1000	50 × 80	4.2	0.50	110	0.15	60	130	13102
	1500	50 × 105	6.3	0.75	60	0.15	40	100	13152
	2200	65 × 105	8.8	1.10	45	0.15	30	60	13222
	3300	65 × 105	10.5	1.65	30	0.15	25	50	13332
	4700	75 × 105	14	2.35	25	0.15	20	40	13472
350	220	35 × 60	1.9	0.16	360	0.10	220	480	15221
	330	35 × 80	2.5	0.23	245	0.10	150	320	15331
	470	35 × 105	3.2	0.33	175	0.10	105	230	15471
	680	50 × 80	3.9	0.48	140	0.10	60	130	15681
	1000	50 × 105	5.4	0.71	65	0.10	50	100	15102
	1500	65 × 105	7.7	1.05	55	0.10	30	70	15152
	2200	65 × 105	9.1	1.54	35	0.10	22	50	15222
	3300	75 × 105	10.8	2.31	30	0.12	20	45	15332
385	150	35 × 60	1.0	0.12	730	0.12	450	935	18151
	220	35 × 80	1.4	0.17	520	0.12	310	630	18221
	330	35 × 105	1.9	0.25	340	0.12	210	425	18331
	470	50 × 80	2.7	0.36	200	0.12	140	300	18471
	680	50 × 105	3.6	0.51	140	0.12	100	205	18681
	1000	65 × 105	5.1	0.75	95	0.12	65	125	18102
	1500	65 × 105	5.7	1.13	80	0.12	45	95	18152
	2200	75 × 105	7.3	1.65	55	0.12	40	75	18222
400	150	35 × 60	1.0	0.12	730	0.12	450	935	16151
	220	35 × 80	1.4	0.18	520	0.12	310	630	16221
	330	35 × 105	1.9	0.26	340	0.12	210	425	16331
	470	50 × 80	2.7	0.38	200	0.12	140	300	16471
	680	50 × 105	3.6	0.54	140	0.12	100	205	16681
	1000	65 × 105	5.1	0.80	95	0.12	65	125	16102
	1500	65 × 105	5.7	1.20	80	0.12	45	95	16152
	2200	75 × 105	7.3	1.76	55	0.12	40	75	16222

Note

- Catalog number applies to the ST version; for STB version (not preferred) replace 8th digit by '5' (2222 114/115 5....).

ADDITIONAL ELECTRICAL DATA		
PARAMETER	CONDITIONS	VALUE
Voltage		
Surge voltage	≤ 250 V versions	$U_s = 1.15 \times U_R$
	≥ 350 V versions	$U_s = 1.1 \times U_R$
Reverse voltage		$U_{rev} \leq 1 \text{ V}$
Current		
Leakage current	after 1 minute at U_R	$I_{L1} \leq 0.006 C_R \times U_R + 4 \mu\text{F}$
	after 5 minutes at U_R	$I_{L5} \leq 0.002 C_R \times U_R + 4 \mu\text{F}$
Inductance		
Equivalent series inductance (ESL)	case $\varnothing D = 35 \text{ mm}$	typ. 13 nH
	case $\varnothing D = 50 \text{ mm}$	typ. 16 nH
	case $\varnothing D = 65 \text{ mm}$	typ. 19 nH
	case $\varnothing D = 75 \text{ mm}$	typ. 20 nH

EQUIVALENT SERIES RESISTANCE (ESR)

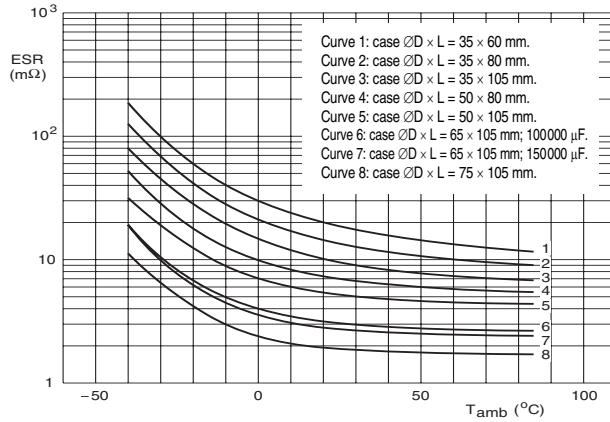

ESR at 100 Hz and $U_R = 10$ V.

Fig.3 Typical ESR as a function of temperature.

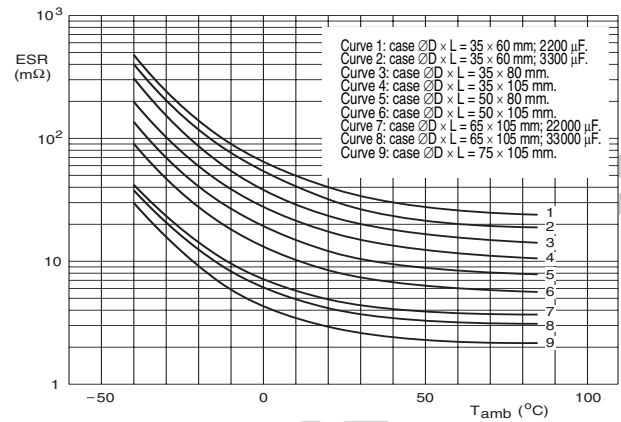

ESR at 100 Hz and $U_R = 63$ V.

Fig.4 Typical ESR as a function of temperature.

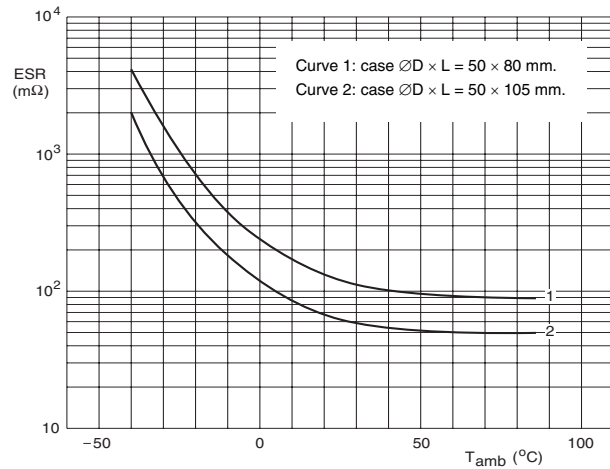

ESR at 100 Hz and $U_R = 250$ V.

Fig.5 Typical ESR as a function of temperature.

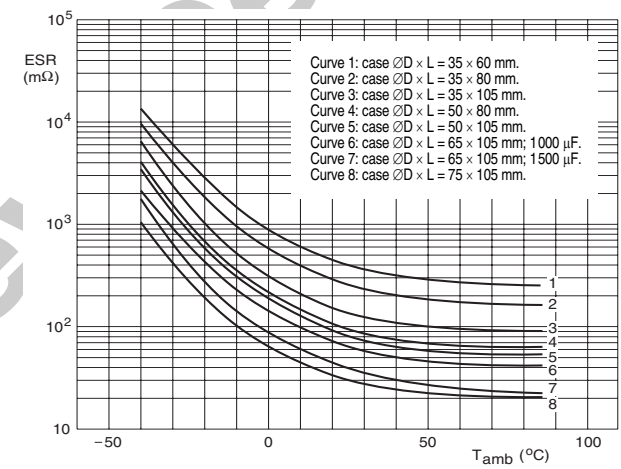

ESR at 100 Hz and $U_R = 250$ V.

Fig.6 Typical ESR as a function of temperature.

IMPEDANCE (Z)

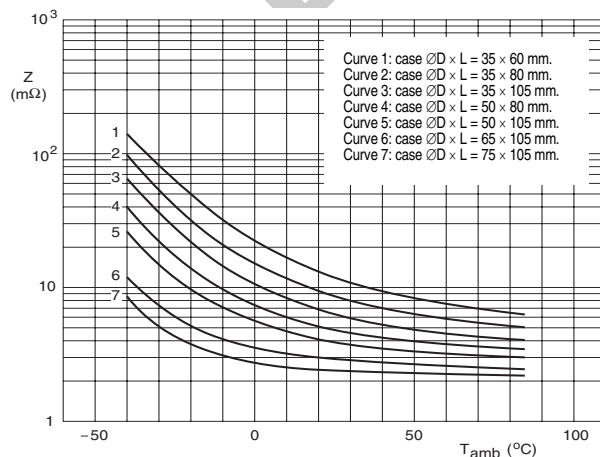

Z at 20 kHz and $U_R = 10$ V.

Fig.7 Typical impedance as a function of temperature.

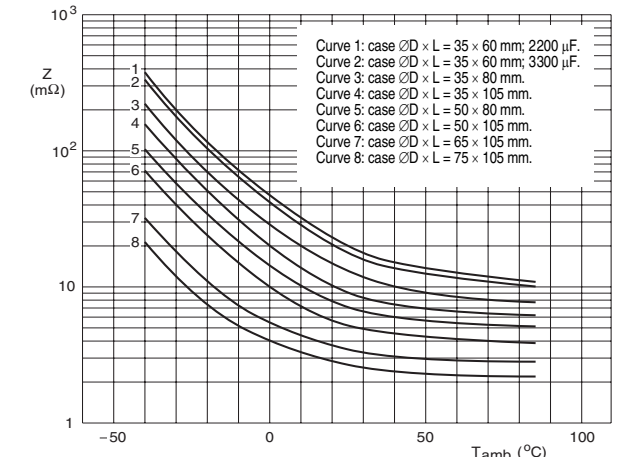

Z at 20 kHz and $U_R = 63$ V.

Fig.8 Typical impedance as a function of temperature.



IMPEDANCE (Z)

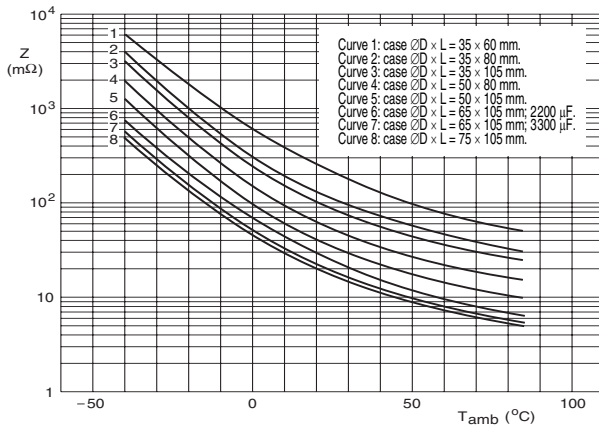

Z at 20 kHz and $U_R = 250$ V.

Fig.9 Typical impedance as a function of temperature.

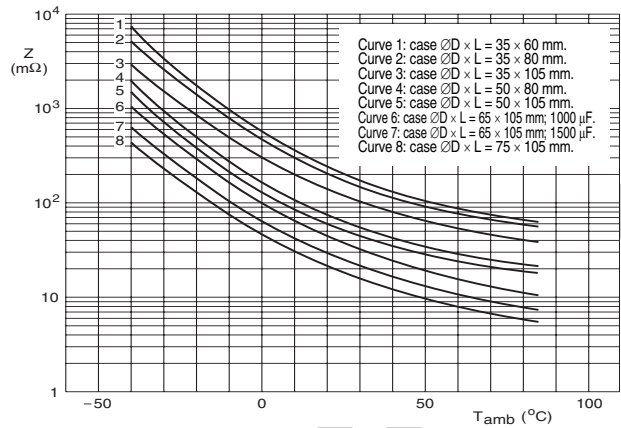

Z at 20 kHz and $U_R = 385$ V.

Fig.10 Typical impedance as a function of temperature.

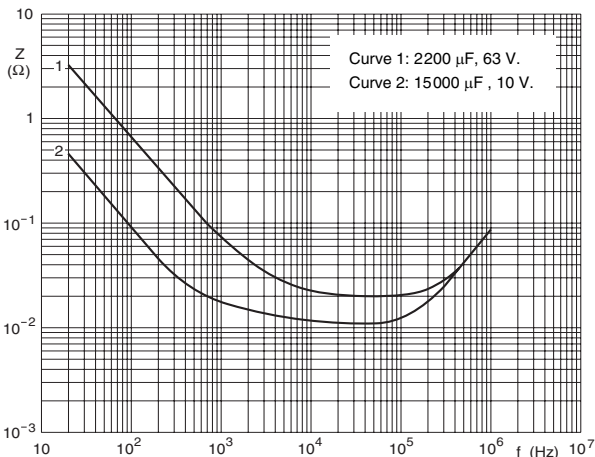

Case $\varnothing D \times L = 35 \times 60$ mm.

$T_{amb} = 20$ °C.

Fig.11 Typical impedance as a function of frequency.

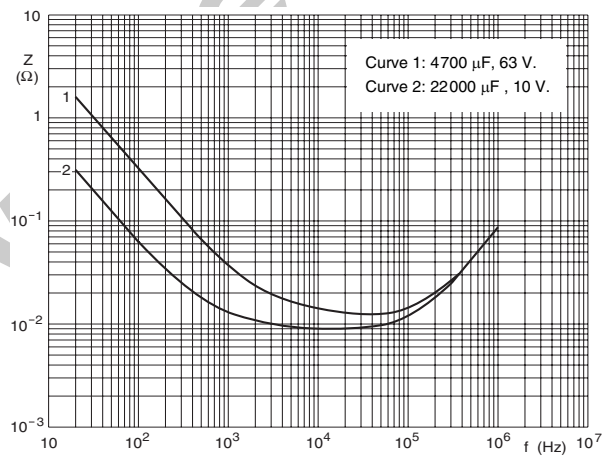

Case $\varnothing D \times L = 35 \times 80$ mm.

$T_{amb} = 20$ °C.

Fig.12 Typical impedance as a function of frequency.

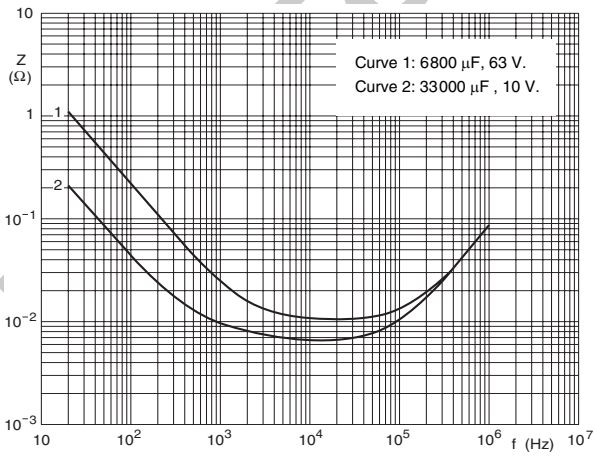

Case $\varnothing D \times L = 35 \times 105$ mm.

$T_{amb} = 20$ °C.

Fig.13 Typical impedance as a function of frequency.

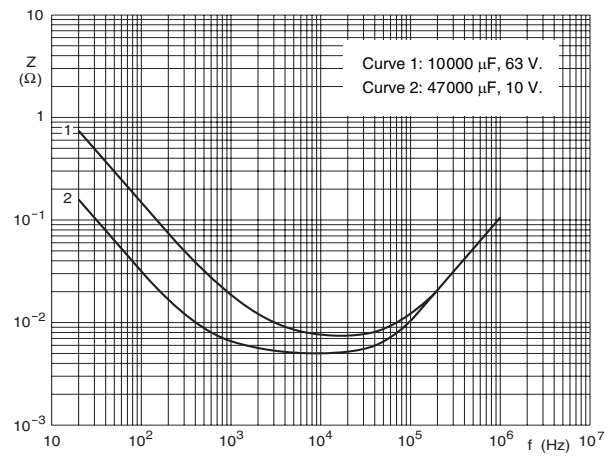

Case $\varnothing D \times L = 50 \times 80$ mm.

$T_{amb} = 20$ °C.

Fig.14 Typical impedance as a function of frequency.

IMPEDANCE (Z)

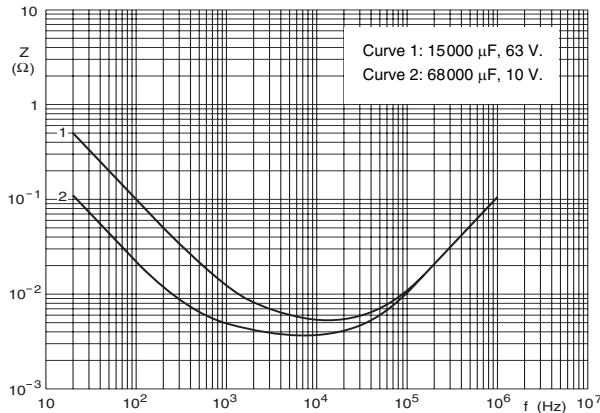

Case $\varnothing D \times L = 50 \times 105$ mm. $T_{amb} = 20$ °C.

Fig. 15 Typical impedance as a function of frequency.

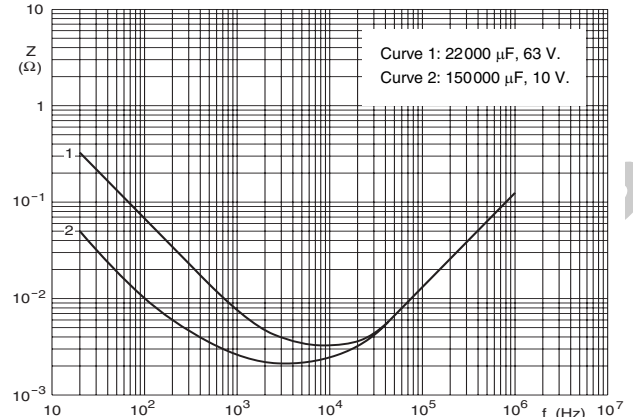

Case $\varnothing D \times L = 65 \times 105$ mm. $T_{amb} = 20$ °C.

Fig. 16 Typical impedance as a function of frequency.

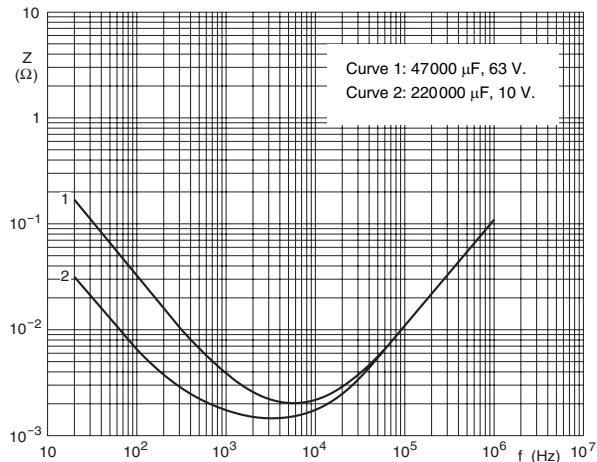

Case $\varnothing D \times L = 75 \times 105$ mm. $T_{amb} = 20$ °C.

Fig. 17 Typical impedance as a function of frequency.

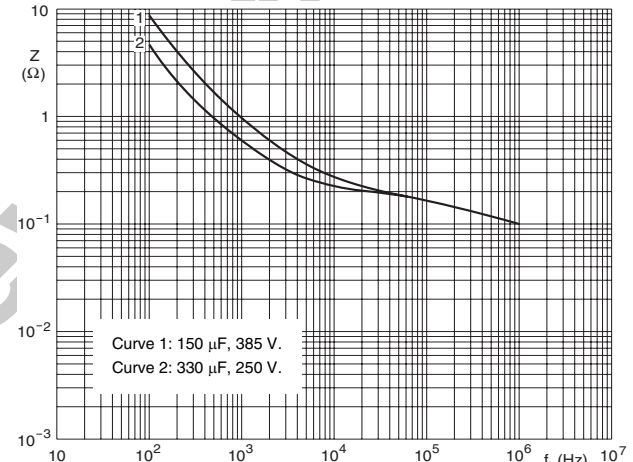

Case $\varnothing D \times L = 35 \times 60$ mm. $T_{amb} = 20$ °C.

Fig. 18 Typical impedance as a function of frequency.

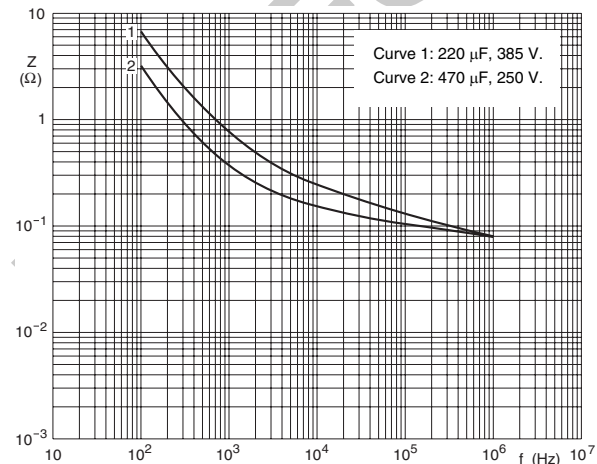

Case $\varnothing D \times L = 35 \times 80$ mm. $T_{amb} = 20$ °C.

Fig. 19 Typical impedance as a function of frequency.

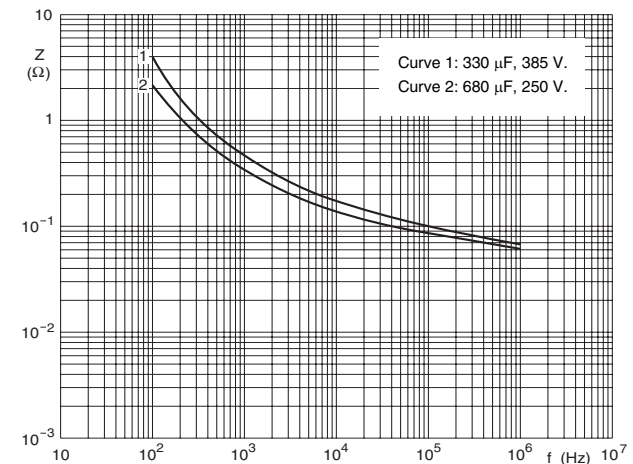

Case $\varnothing D \times L = 35 \times 105$ mm. $T_{amb} = 20$ °C.

Fig. 20 Typical impedance as a function of frequency.



IMPEDANCE (Z)

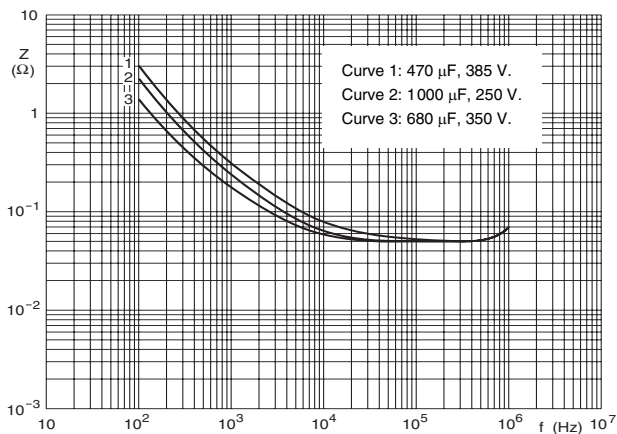

Case $\varnothing D \times L = 50 \times 80$ mm.

$T_{amb} = 20$ °C.

Fig.21 Typical impedance as a function of frequency.

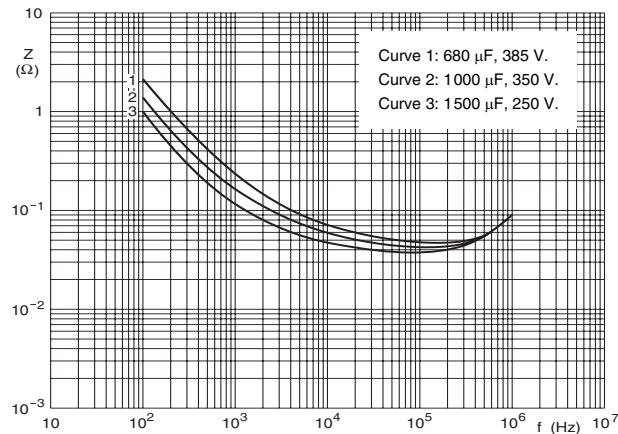

Case $\varnothing D \times L = 50 \times 105$ mm.

$T_{amb} = 20$ °C.

Fig.22 Typical impedance as a function of frequency.

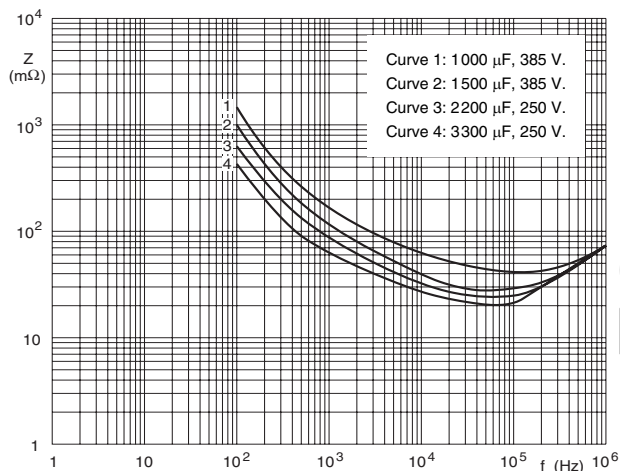

Case $\varnothing D \times L = 65 \times 105$ mm.

$T_{amb} = 20$ °C.

Fig.23 Typical impedance as a function of frequency.

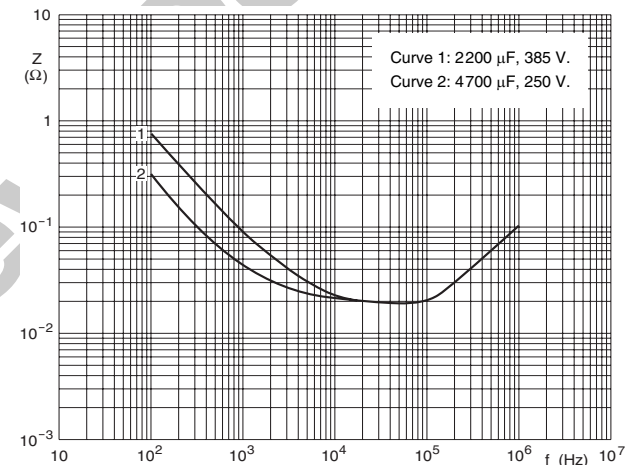

Case $\varnothing D \times L = 75 \times 105$ mm.

$T_{amb} = 20$ °C.

Fig.24 Typical impedance as a function of frequency.



RIPPLE CURRENT AND USEFUL LIFE

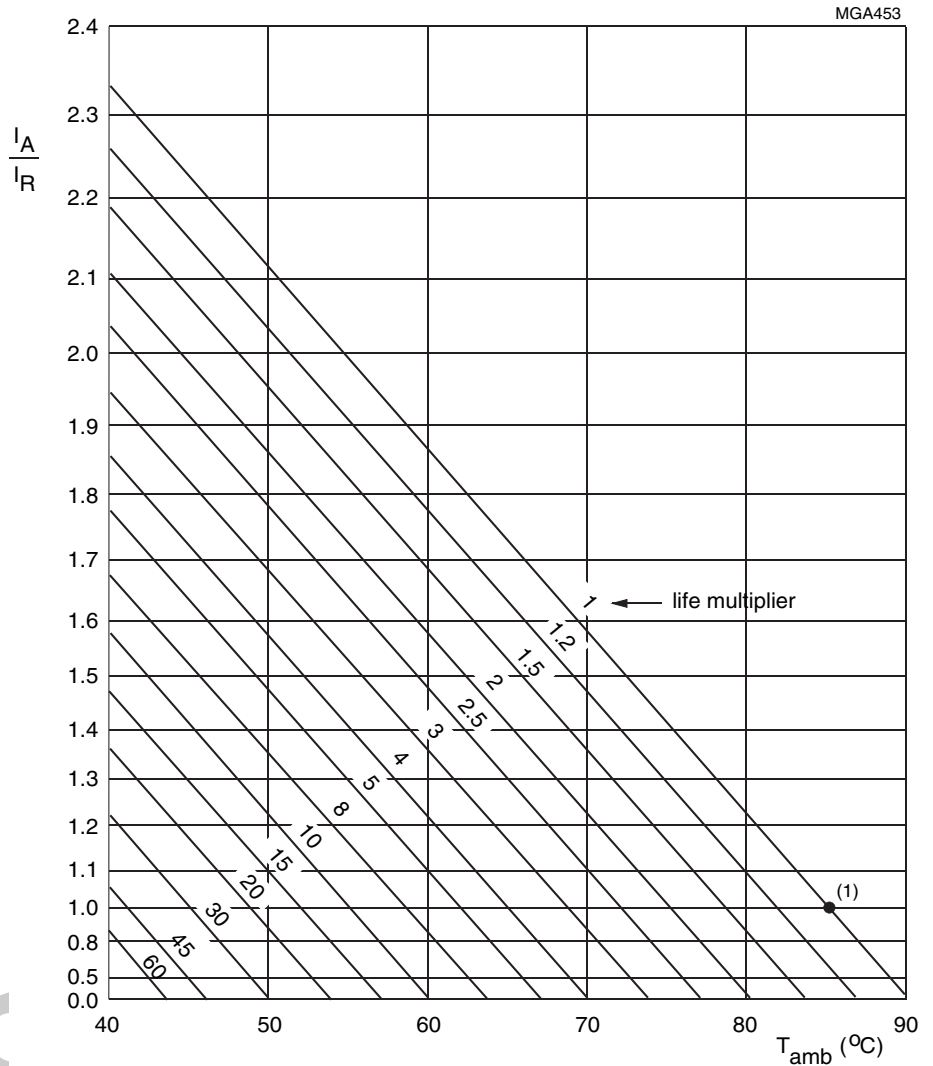

i_A = actual ripple current at 100 Hz and 85 °C.
 i_R = actual ripple current at 100 Hz and 85 °C.
 With an absolute maximum of 50 A at 85 °C.
 (1) Useful life at 85 °C and i_R applied:
 20000 hours (12000 hours for 400 V types).

Fig.25 Multiplier of useful life as a function of ambient temperature and ripple current load.

Table 4

MULTIPLIER OF RIPPLE CURRENT (i_R) AS A FUNCTION OF FREQUENCY	
FREQUENCY (Hz)	i_R MULTIPLIER
50	0.83
100	1.00
200	1.10
400	1.15
1000	1.19
≥2000	1.20



Table 5

TEST PROCEDURES AND REQUIREMENTS			
TEST		PROCEDURE (quick reference)	REQUIREMENTS
NAME OF TEST	REFERENCE		
Endurance	IEC 60384-4/ EN130300 subclause 4.13	$T_{amb} = 85\text{ }^{\circ}\text{C}$; U_R applied; 8000 hours (400 V types: 5000 hours)	$U_R \leq 100\text{ V}$; $\Delta C/C: \pm 15\%$ $U_R > 100\text{ V}$; $\Delta C/C: \pm 10\%$ $\tan \delta \leq 1.3 \times \text{spec. limit}$ $Z \leq 2 \times \text{spec. limit}$ $I_{L5} \leq \text{spec. limit}$
Useful life	CECC 30301 subclause 1.8.1	$T_{amb} = 85\text{ }^{\circ}\text{C}$; U_R and I_R applied; 20000 hours (400 V types: 12000 hours)	$U_R \leq 100\text{ V}$; $\Delta C/C: \pm 45\%$ $U_R > 100\text{ V}$; $\Delta C/C: \pm 30\%$ $\tan \delta \leq 3 \times \text{spec. limit}$ $Z \leq 3 \times \text{spec. limit}$ $I_{L5} \leq \text{spec. limit}$ no short or open circuit, no visible damage total failure percentage: $U_R \leq 100\text{ V}: \leq 1\%$; $U_R > 100\text{ V}: \leq 3\%$
Shelf life (storage at high temperature)	IEC 60384-4/ EN130300 subclause 4.17	$T_{amb} = 85\text{ }^{\circ}\text{C}$; no voltage applied; 500 hours after test: U_R to be applied for 30 minutes, 24 to 48 hours before measurement	$\Delta C/C: \pm 10\%$ $\tan \delta \leq 1.2 \times \text{spec. limit}$ $I_{L5} \leq 2 \times \text{spec. limit}$



Disclaimer

All product specifications and data are subject to change without notice.

Vishay Intertechnology, Inc., its affiliates, agents, and employees, and all persons acting on its or their behalf (collectively, "Vishay"), disclaim any and all liability for any errors, inaccuracies or incompleteness contained herein or in any other disclosure relating to any product.

Vishay disclaims any and all liability arising out of the use or application of any product described herein or of any information provided herein to the maximum extent permitted by law. The product specifications do not expand or otherwise modify Vishay's terms and conditions of purchase, including but not limited to the warranty expressed therein, which apply to these products.

No license, express or implied, by estoppel or otherwise, to any intellectual property rights is granted by this document or by any conduct of Vishay.

The products shown herein are not designed for use in medical, life-saving, or life-sustaining applications unless otherwise expressly indicated. Customers using or selling Vishay products not expressly indicated for use in such applications do so entirely at their own risk and agree to fully indemnify Vishay for any damages arising or resulting from such use or sale. Please contact authorized Vishay personnel to obtain written terms and conditions regarding products designed for such applications.

Product names and markings noted herein may be trademarks of their respective owners.