

6-Channel Ultra Low Dropout LED Driver

FEATURES

- Charge pump modes: 1x, 1.33x, 1.5x, 2x
- Ultra low dropout PowerLite™ Current Regulator*
- Drives up to 6 LEDs at 32mA each
- 1-wire LED current programming
- Power efficiency up to 94%
- Low input noise & ripple in all charge pump modes
- Low current shutdown mode
- Short circuit current limiting
- Thermal shutdown protection
- Available in 3 x 3 x 0.8 mm 16-pin TQFN package

APPLICATION

- Keypad and Display Backlight
- Cellular Phones
- Digital Still Cameras
- PDAs and Smartphones

DESCRIPTION

The LDS8869 is a high efficiency multi-mode fractional charge pump with ultra low dropout voltage that can drive up to six LEDs. Inclusion of a 1.33x fractional charge pump mode and ultra low dropout PowerLite™ Current Regulator (PCR) increases

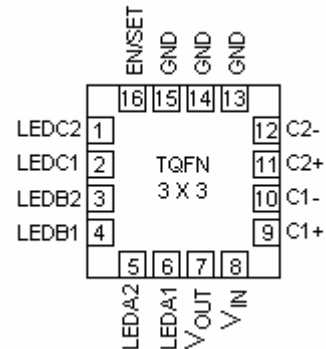

device's efficiency up to 94%. New mode requires no additional external capacitors.

The EN/SET logic input functions as a chip enable and a current setting interface.

The LEDs current is programmable by one wire digital interface from 0.5 to 32mA in 0.5mA steps or from zero to 3.75mA in 0.25mA steps. Every LED bank with two LEDs each may be turned on/off or programmed separately

Low noise input ripple is achieved by operating at a constant switching frequency which allows the use of small external ceramic capacitors. The multi-fractional charge pump supports a wide range of input voltages from 2.7V to 5.5V.

The device is available in in 16-lead TQFN 3 mm x 3 mm package with a max height of 0.8 mm.

TYPICAL APPLICATION CIRCUIT

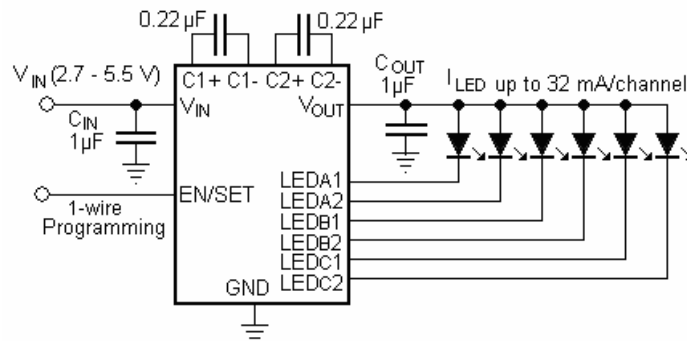

LDS8869

ABSOLUTE MAXIMUM RATINGS

Parameter	Rating	Unit
V _{IN} , LEDx, C1±, C2± voltage	6	V
V _{OUT} voltage	6	V
EN/SET voltage	V _{IN} + 0.7V	V
Storage Temperature Range	-65 to +160	°C
Junction Temperature Range	-40 to +125	°C
Soldering Temperature	300	°C

RECOMMENDED OPERATING CONDITIONS

Parameter	Rating	Unit
V _{IN}	2.7 to 5.5	V
Ambient Temperature Range	-40 to +85	°C

Typical application circuit with external components is shown on page 1.

ELECTRICAL OPERATING CHARACTERISTICS

(Over recommended operating conditions unless specified otherwise) V_{in} = 3.6V, C1 = C2 = 0.22 µF, C_{in} = C_{out} = 1 µF, EN = High, T_{AMB} = 25°C

Name	Conditions	Min	Typ	Max	Units
Quiescent Current	1x mode, no load		1.7	2.5	mA
Shutdown Current	V _{EN} = 0V			1	µA
LED Current Accuracy	1mA ≤ I _{LED} ≤ 31mA	-5	±3	+5	%
LED Channel Matching	(I _{LED} - I _{LEDAVG}) / I _{LEDAVG}	-5	±3	+5	%
Output Resistance (open loop) ¹	1x mode		0.8		Ω
	1.33x mode		3.5		
	1.5x mode		5.5		
	2x mode		6.5		
Charge Pump Frequency	1.33x		0.8		MHz
	1.5x mode and 2x mode		1.1		
Output short circuit Current Limit	V _{OUT} < 0.5V		35		mA
Input Current Limit			450		mA
1x to 1.33x, 1.33x to 1.5x, or 1.5x to 2x Transition Thresholds at any LED pin	I _{LED} = 30 mA		75	130	mV
1.33x to 1x Mode Transition Hysteresis			600		mV
Transition Filter Delay			800		µs
EN/SET Pin	Input Leakage	-1		1	µA
	Logic Level	High	1.3		V
		Low			
Thermal Shutdown			150		°C
Thermal Hysteresis			20		
Under Voltage Lockout (UVLO)			2.2		V
Over Voltage Protection				6.2	V

Note: 1. Sample test only

RECOMMENDED EN/SET TIMING

For $2.5 \leq V_{IN} \leq 5.5V$, over full ambient temperature range -40 to $+85^{\circ}C$.

Symbol	Name	Conditions	Min	Typ	Max	Units
t_{SETUP}	EN/SET setup from shutdown		10		100	μs
t_{LO}	EN/SET program low time		0.2		100	μs
t_{HI}	EN/SET program high time		0.2		100	μs
t_{OFF}	EN/SET low time to shutdown		1.5			ms
$t_{DATADELAY}$	EN/SET Delay to DATA		500			μs
$t_{RESETDELAY}$	EN/SET Delay High to ADDRESS		2			ms

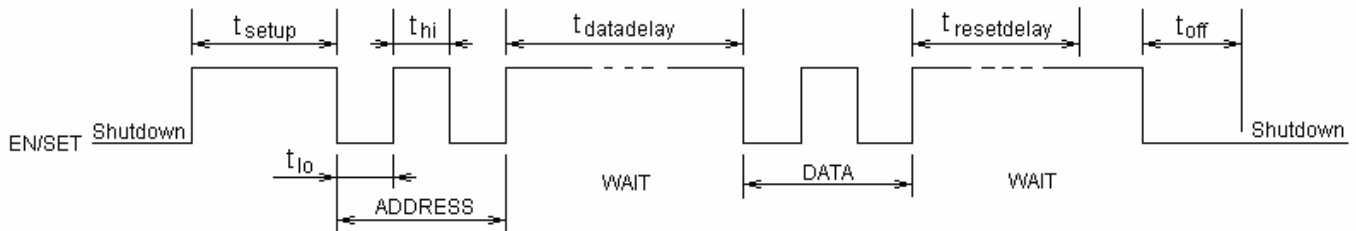

Figure 1. EN/SET One Wire Addressable Timing Diagram

REGISTER CONFIGURATION AND PROGRAMMING

Table 1. Register Address and Data

Register	Address Pulses	Description	Bits	DATA pattern			
				Bit 3	Bit 2	Bit 1	Bit 0
REG1	1	Bank Enable and IMODE	4	IMODE	ENC	ENB	ENA
REG2	2	Global Current Setting*	6	See Table 3 for values			
REG3	3	Bank C Current Setting	6				
REG4	4	Bank B Current Setting	6				
REG5	5	Bank A Current Setting	6				
REG6	6	Return Lockout	1				RTLKO

Note: *) If Global current setting register Reg2 is used, registers Reg3 – Reg5 should be empty, and vice versa If registers Reg3 – Reg5 are used, Reg2 should be empty to prevent data interference.

Table 2. Reg1 Code

Data pulses	Reg1 Bit				Data pulses	Reg1 Bit				Data pulses	Reg1 Bit			
	3	2	1	0		3	2	1	0		3	2	1	0
0	0	0	0	0	6	1	0	1	0	12	0	1	0	0
1	1	1	1	1	7	1	0	0	1	13	0	0	1	1
2	1	1	1	0	8	1	0	0	0	14	0	0	1	0
3	1	1	0	1	9	0	1	1	1	15	0	0	0	1
4	1	1	0	0	10	0	1	1	0	16	0	0	0	0
5	1	0	1	1	11	0	1	0	1					

Note: If bits Bit0 – Bit2 are set to zero, the corresponding LED bank is disabled.

Table 3. REG2-5 Current Setting Registers

Data Pulses	Reg2-5 value (binary)	LED Current, mA, IMODE = 0	LED Current, mA, IMODE = 1
0	000000	0.0	0.5
1	111111	3.75	32
2	111110	3.5	31.5
3	111101	3.25	31.0
4	111100	3	30.5
5	111011	2.75	30
6	111010	2.5	29.5
7	111001	2.25	29
8	111000	2	28.5
9	110111	1.75	28
10	110110	1.5	27.5
11	110101	1.25	27
12	110100	1	26.5
13	110011	0.75	26
14	110010	0.5	25.5
15	110001	0.25	25
16	110000	0.0	24.5
17	101111		24
18	101110		23.5
19	101101		23
20	101100		22.5
21	101011		22
22	101010		21.5
23	101001		21
24	101000		20.5
25	100111		20
26	100110		19.5
27	100101		19
28	100100		18.5
29	100011		18
30	100010		17.5
31	100001		17
32	100000		16.5

Data Pulses	Reg2-5 value (binary)	LED Current, mA, IMODE = 0	LED Current, mA, IMODE = 1
33	011111		16
34	011110		15.5
35	011101		15
36	011100		14.5
37	011011		14
38	011010		13.5
39	011001		13
40	011000		12.5
41	010111		12
42	010110		11.5
43	010101		11
44	010100		10.5
45	010011		10
46	010010		9.5
47	010001		9
48	010000		8.5
49	001111		8
50	001110		7.5
51	001101		7
52	001100		6.6
53	001011		6
54	001010		5.5
55	001001		5
56	001000		4.5
57	000111		4
58	000110		3.5
59	000101		3
60	000100		2.5
61	000011		2
62	000010		1.5
63	000001		1
64	000000		0.5

PROGRAMMING EXAMPLES

Programming 6 LEDs to 32mA

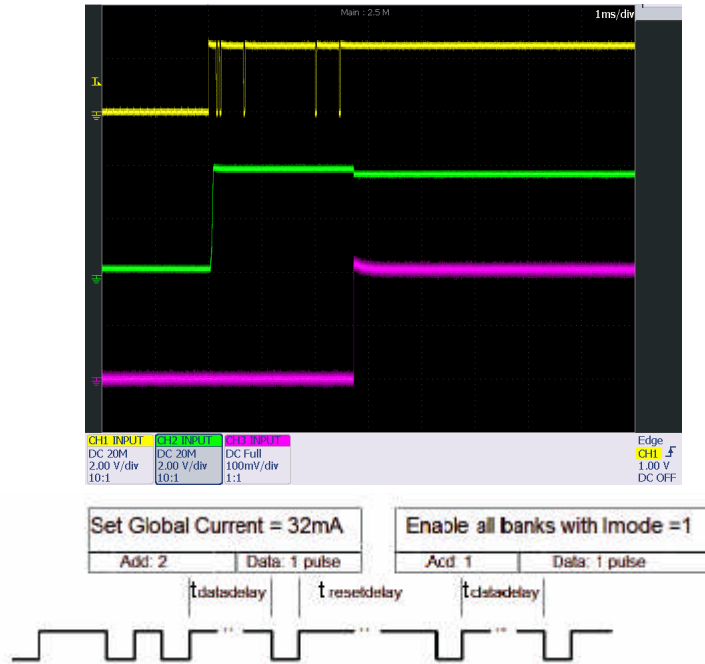

Programming 6 LED to 1mA

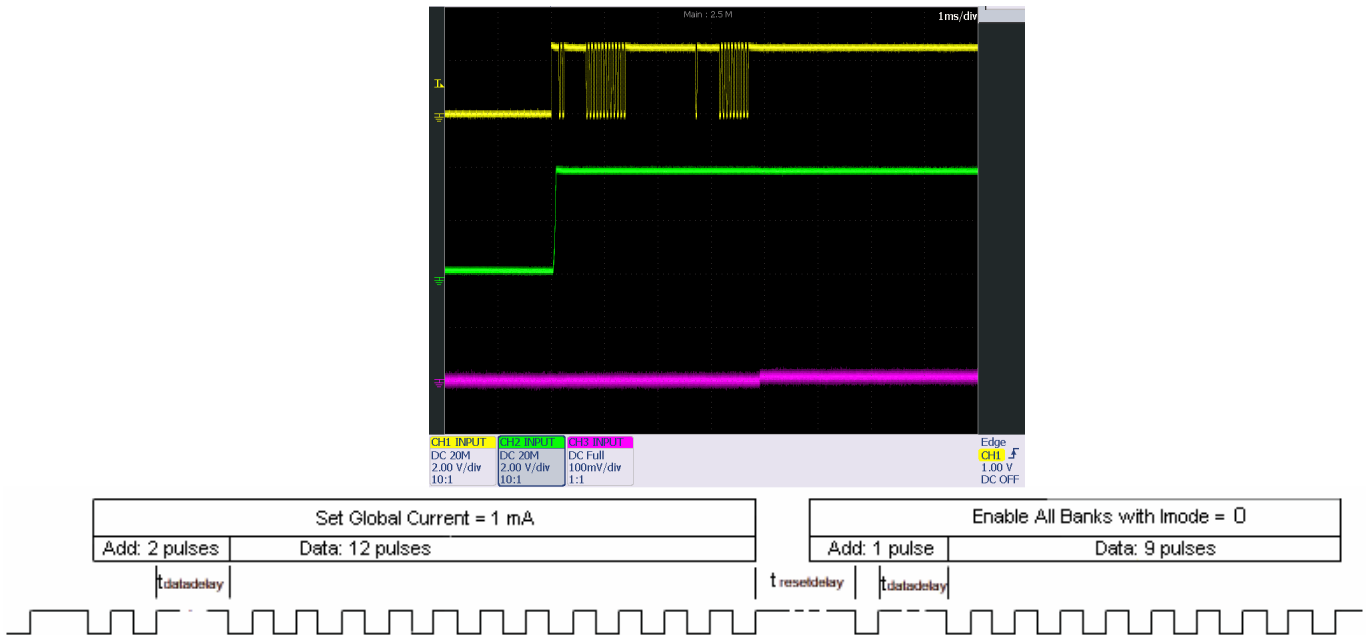

TYPICAL CHARACTERISTICS

$V_{in} = 3.6V$, $I_{OUT} = 120mA$ (6 LEDs at 20mA), $C_1 = C_2 = 0.22 \mu F$, $C_{IN} = C_{OUT} = 1 \mu F$, $T_{AMB} = 25^\circ C$ unless otherwise specified

Efficiency vs. Input Voltage

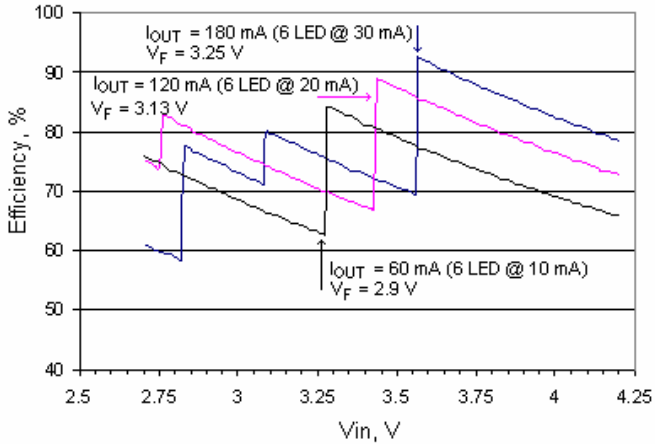

Power-Up in 1x Mode

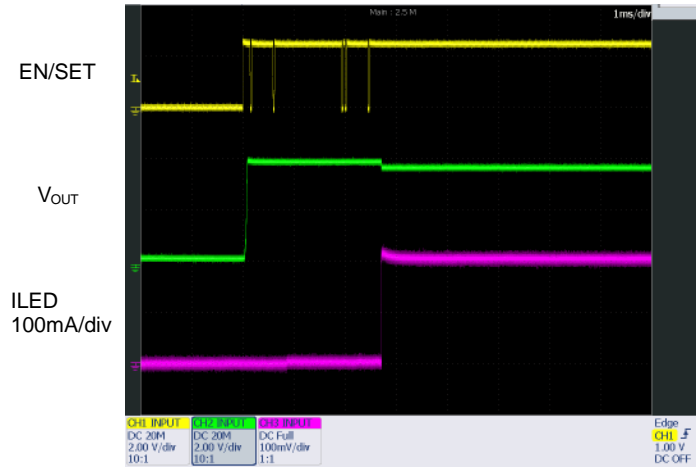

Power-Up in 1.33x Mode

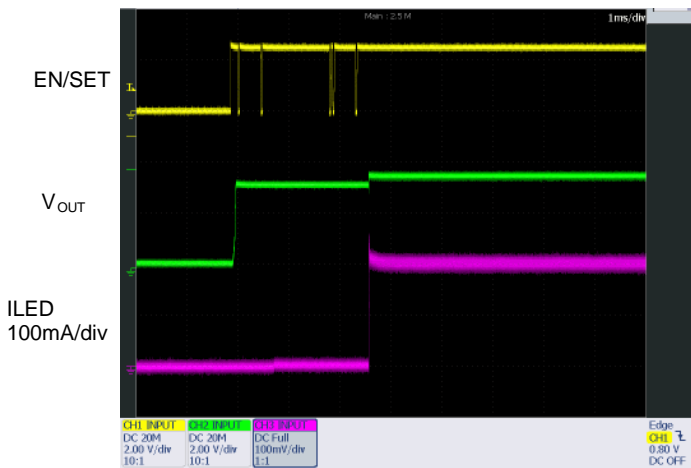

Power-Up in 1.5x Mode

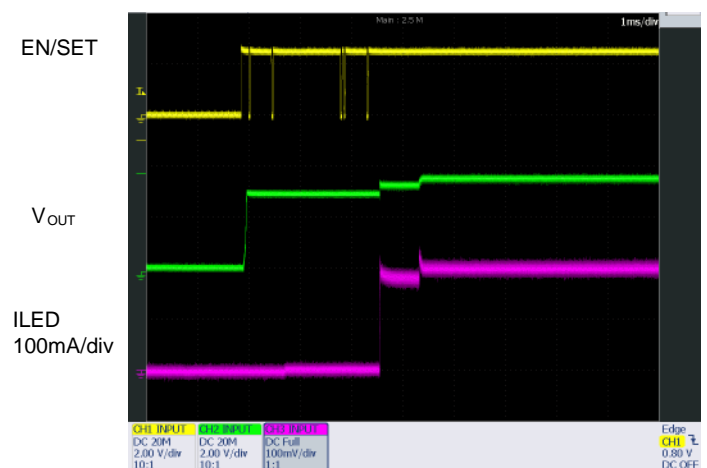

Power-Up in 2x Mode

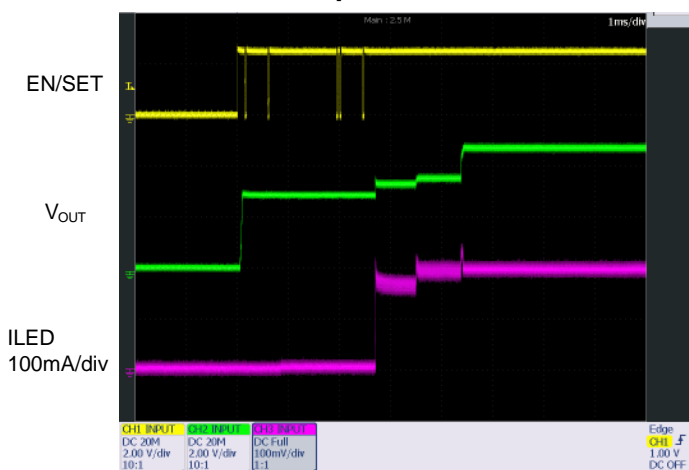

Power-Down Delay (1x Mode)

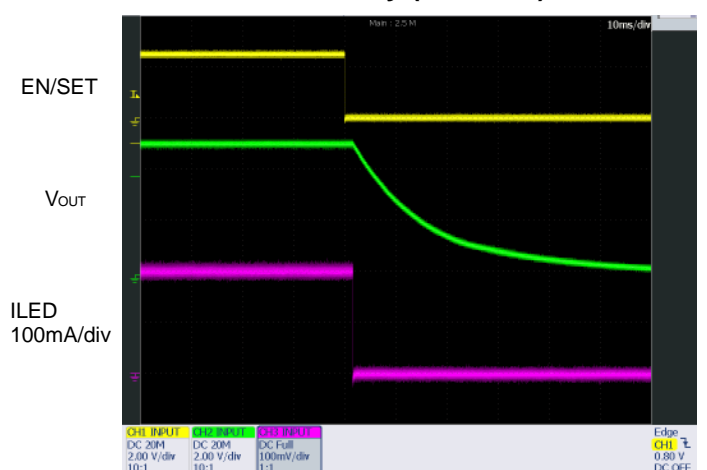

Operating Waveforms in 1x Mode

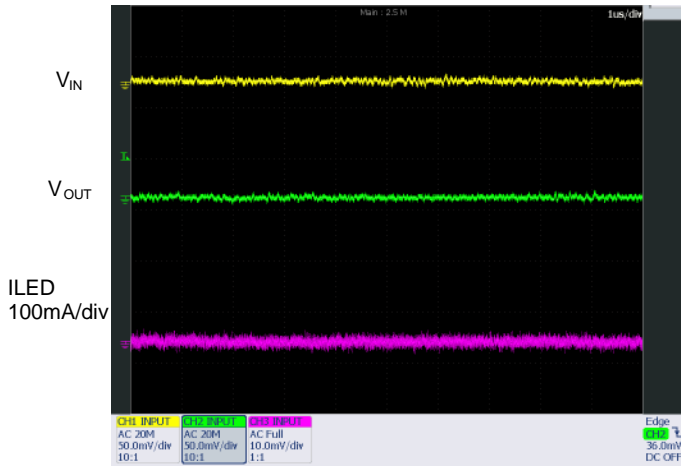

Operating Waveforms in 1.33x Mode

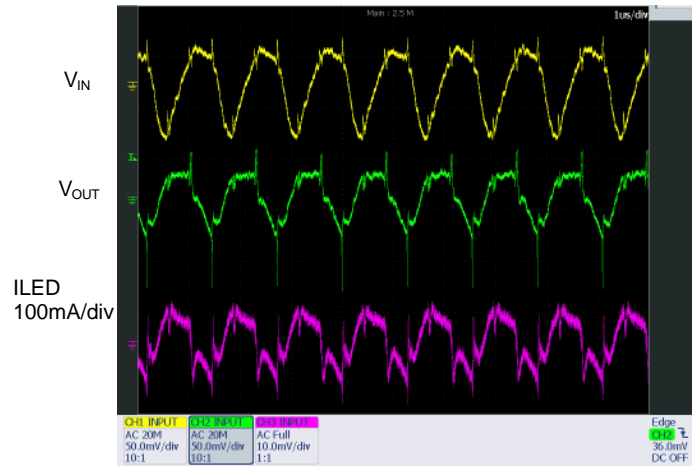

Operating Waveforms in 1.5x Mode

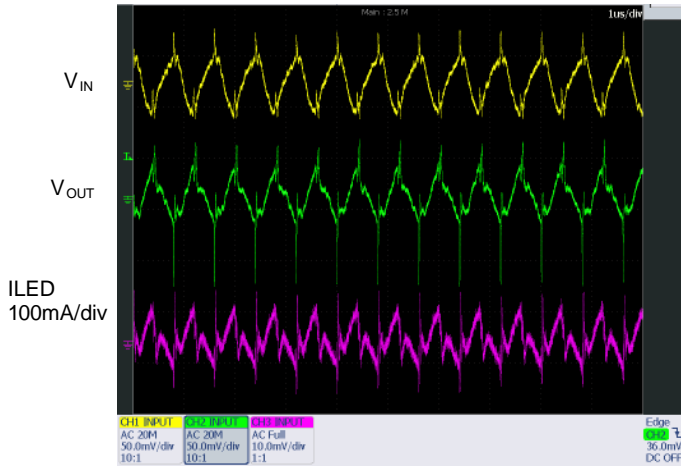

Operating Waveforms in 2x Mode

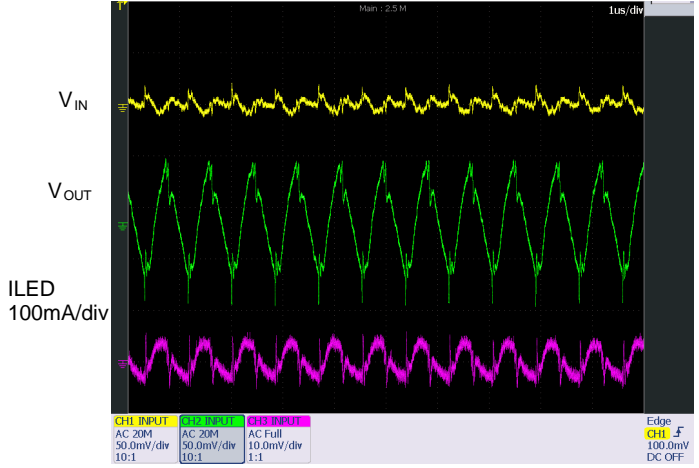

LDS8869

PIN DESCRIPTION

Pin #	Name	Function
1	LEDC2	LEDC2 cathode terminal
2	LEDC1	LEDC1 cathode terminal
3	LEDB2	LEDB2 cathode terminal
4	LEDB1	LEDB1 cathode terminal
5	LEDA2	LEDA2 cathode terminal
6	LEDA1	LEDA1 cathode terminal
7	V _{OUT}	Charge pump output connected to the LED anodes
8	V _{IN}	Charge pump input, connect to battery or supply
9	C1+	Bucket capacitor 1 Positive terminal
10	C1-	Bucket capacitor 1 Negative terminal
11	C2+	Bucket capacitor 2 Positive terminal
12	C2-	Bucket capacitor 2 Negative terminal
13, 14	GND	Ground Reference
15	GND	Ground Reference
16	EN/SET	Device enable (active high) and Dimming Control
TAB	TAB	Connect to GND on the PCB

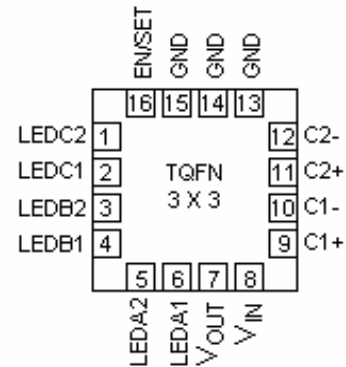

Top view: TQFN 16-lead 3 X 3 mm

PIN FUNCTION

V_{IN} is the supply pin for the charge pump. A small 1 μ F ceramic bypass capacitor is required between the Vin pin and ground near the device. The operating input voltage range is from 2.5V to 5.5V. Whenever the input supply falls below the under-voltage threshold (2.2 V), all the LED channels are disabled and the device enters shutdown mode.

EN/SET is the enable and one wire addressable control logic input for all LED channels. Guaranteed levels of logic high and logic low are set at 1.3V and 0.4V respectively. When EN/SET is initially taken high, the device becomes enabled and all LED currents remain at 0mA. To place the device into zero current mode, the EN/SET pin must be held low for more than 1.5ms.

V_{OUT} is the charge pump output that is connected to the LED anodes. A small 1 μ F ceramic bypass

capacitor is required between the Vout pin and ground near the device.

GND is the ground reference for the charge pump. The pin must be connected to the ground plane on the PCB.

C1+, C1- are connected to each side of the ceramic bucket capacitor C1

C2+, C2- are connected to each side of the ceramic bucket capacitor C2

LEDA1 – LEDC2 provide the internal regulated current source for each of the LED cathodes. These pins enter high-impedance zero current state whenever the device is in shutdown mode.

TAB is the exposed pad underneath the package. For best thermal performance, the tab should be soldered to the PCB and connected to the ground plane

BLOCK DIAGRAM

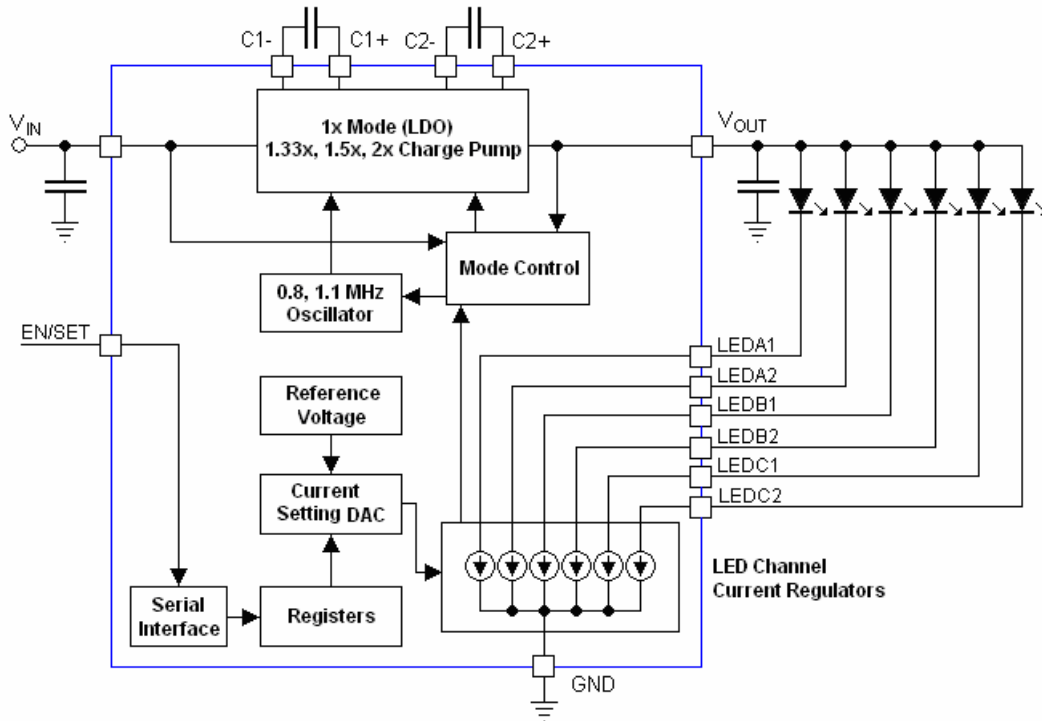

Figure 2. LDS8869 Functional Block Diagram

BASIC OPERATION

At power-up, EN pin should be logic LOW. During power-up device performs internal circuits reset that requires less than 10 μ s. To start device, EN pin should be set logic HIGH at least 10 μ s after V_{IN} applied. Device starts operating at 1x mode at which the V_{OUT} is approximately equal to V_{IN} (less any internal voltage losses). If the output voltage is sufficient to regulate all LED currents, the device remains in 1x operating mode.

The low dropout PowerLite™ Current regulator (PCR) performs well at input voltages up to 75 mV above LED forward voltage V_F significantly increasing driver's efficiency. The LDS8869 monitors voltage drop V_d across PCR at every channel in ON state. If this voltage falls below 75 mV (typical) at any one channel, (channel with LED with highest forward voltage), the Mode Control Block changes charge pump mode to the next multiplication ratio.

$V_d (LEDX1/2) = V_{IN} \times M - V_F - R_{cp} \times I_{out}$, where R_{cp} is a Charge Pump Output Resistance at given mode, I_{out} is sum of all LED currents, and M is a charge pump' multiplication ratio.

If the input voltage is insufficient or falls to a level where V_d ≤ 75 mV, and the regulated currents cannot be maintained, the low dropout PowerLite™ Current

Regulator switches the charge pump into 1.33x mode (after a fixed delay time of about 800 μ s). In 1.33x mode, the charge pump' output voltage is approximately equal to 1.33 times the input supply voltage (less any internal voltage losses).

This sequence repeats at every mode until driver enters the 2x mode.

If the device detects a sufficient input voltage is present to drive all LED currents in 1x mode, it will change automatically back to 1x mode. This only applies for changing back to the 1x mode. The difference between the input voltage when exiting 1x mode and returning to 1x mode is called the 1x mode transition hysteresis (about 600mV).

LED Current Setting

The current in each of the six LED channels is programmed through the 1-wire EN/SET digital control input. By pulsing this signal according to a specific protocol, a set of internal registers can be addressed and written into allowing to configure each bank of LEDs with the desired current. There are six registers: the first five are 4 bits long and the sixth is 1 bit long. The registers are programmed by first

LDS8869

selecting the register address and then programming data into that register.

An internal counter records the number of falling edges to identify the address and data. The address is serially programmed adhering to low and high duration time delays. One down pulse corresponds to register 1 being selected. Two down pulses correspond to register 2 being selected and so on up to register 6. t_{LO} and t_{HI} must be within 200ns to 100µs. Any pulse with less than 200 ns width may be ignored.

Once the final rising edge of the address pulse is programmed, the user must wait at least 500µs before programming the first data pulse. Any falling edge after this minimum delay will be recognised as a first data pulse.

Data in a register is reset once it is selected by the address pulses. If a register is selected but no data is programmed, next pulse sequence will be recognized as data only. Do not send register address only without following data because it may disrupt normal device operation.

Once the final rising edge of the data pulses is programmed, the user must wait at least 1.5ms before programming another address. If programming fails or is interrupted, the user must wait at least 2 ms ($t_{RESETDELAY}$) from the last rising edge before reprogramming can commence.

Upon EN/SET pin goes high the device automatically starts looking for an address. If no falling edge is detected within 100µs, then the user must wait at least 2 ms before trying to program the device again.

The device requires a minimum 10µs delay to ensure the initialization of the internal logic at power-up. After this time delay, EN/SET pin may be set high and the device registers may be programmed adhering to the timing constraints shown in Figure 1.

Register REG1 allows to set the mode and select the pairs of LEDs to be turned on. A low LED current mode exists to allow for very low current operation under 4mA per channel. If IMODE equals 1, the high current range is selected up to 32mA. If IMODE is set to 0, all currents are divided by 8. Each bank of LEDs (A, B or C) can be turned on independently by setting the respective bit ENA, ENB, ENC to 1.

Register REG2 allows to set the same current for all 6 channels. REG3, REG4, REG5 allow to set the current respectively in banks C, B and A. The three banks can be programmed with independent current values.

REG6 contains the return lockout (RTLKO) bit. This stops the charge pump returning to 1x mode. One pulse sets it to 1. Two pulses set RTLKO to 0. When RTLKO is set to 1, the charge pump cannot automatically return to 1x mode when in one of the charge pump modes. The device can however move from 1x to 1.33x, or to 1.5x and 2x if the input voltage is not sufficient to drive the programmed LED currents.

REG6 also triggers a charge pump. This forces the charge pump to start from 1x mode and determine the correct mode it should be in to drive the LEDs most efficiently. If the input voltage has risen or the device has been reprogrammed to other LED values, it is recommended to trigger this reset allowing the charge pump to run in the most efficient mode.

To power-down the device and turn-off all current sources, the EN/SET input should be low for at least 1.5ms (t_{OFF}) or longer. The driver typically powers-down with a delay of about 1ms. All register data are cleared.

Unused LED Channels

For applications with only four or two LEDs, unused LED banks can be disabled via the enable register internally and left to float or connect to V_{OUT} .

For applications requiring 1, 3, or 5 channels, the unused LED pins should be tied to V_{OUT} (see Figure 3). If LED pin voltage is within 1 V of V_{OUT} , then the channel is switched off and a 250 µA test current is placed in the channel to sense when the channel moves below $V_{OUT} - 1.5 V$.

Protection Modes

The LDS8869 has follow protection modes:

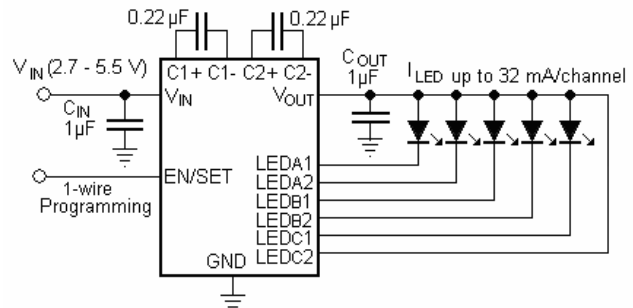

Figure 3. Application circuit with 5 LEDs

1. LED short to V_{OUT} protection

If LED pin is shorted to V_{OUT} , LED burned out becomes as short circuit, or LED pin voltage is within from V_{OUT} to $(V_{OUT} - 1.5V)$ range, LDS8869

recognizes this condition as “LED Short” and disables this channel. If LED pin voltage is less than ($V_{out} - 1.5V$), LDS8869 restores LED current at this particular channel to programmed value.

2. V_{OUT} Over-Voltage Protection

The charge pump’ output voltage V_{OUT} automatically limits at about 6.2 V maximum. This is to prevent the output pin from exceeding its absolute maximum rating.

3. V_{OUT} Short Circuit Protection

If V_{OUT} is shorted to ground before LDS8869 is enabled, input current may increase up to 200 – 300 mA within 20 μs after enable and is limited to 35 – 40 mA after that.

4. Over-Temperature Protection

If the die temperature exceeds +150°C, the driver will enter shutdown mode. The LDS8869 requires restart after die temperature falls below 130°C.

5. Input Voltage Under-Voltage Lockout

If V_{IN} falls below 2.2 V (typical value), LDS8869 enters shutdown mode and all registers data are cleared. Device requires restart when input voltage rises above 2.3 V. To restart device, set EN/SET pin logic low, turn V_{IN} off/on, set EN/SET pin logic high, and program I_{LED} using 1-wire interface.

6. Low V_{IN} or High LED V_F Voltage Detection

If, in 2x mode, V_{IN} is too low to maintain regulated LED current for given LED V_F , or LED becomes an open circuit, or if any LED at active channels is disconnected, LDS8869 starts subsequently changing modes (2x – 1x – 1.33x -1.5x – 2x -...) in an attempt to compensate insufficient voltage. As a result, average current at all other channels that are ON may fall below regulated level.

LED Selection

LEDs with forward voltages (V_F) ranging from 1.6 V to 3.6 V may be used. Charge pumps operate in highest efficiency when V_F voltage is close to V_{IN} voltage multiplied by switching mode, i.e. $V_{IN} \times 1$, $V_{IN} \times 1.33$, and so on. If the power source is a Li-ion battery, LEDs with $V_F = 2.7V - 3.3V$ are recommended to achieve highest efficiency performance and extended operation on a single battery charge.

External Components

The driver requires two external 1 μF ceramic capacitors (C_{IN} and C_{OUT}) and two 0.22 μF ceramic capacitors (C1 and C2) X5R or X7R type. Capacitors C1 and C2 may be increased up to 1 μF to improve

charge pump efficiency by 3%. In all charge pump modes, the input current ripple is very low, and an input bypass capacitor of 1 μF is sufficient.

In 1x mode, the device operates in linear mode and does not introduce switching noise back onto the supply.

Recommended Layout

In charge pump mode, the driver switches internally at a high frequency. It is recommended to minimize trace length to all four capacitors. A ground plane should cover the area under the driver IC as well as the bypass capacitors. Short connection to ground on capacitors C_{IN} and C_{OUT} can be implemented with the use of multiple via. A copper area matching the TQFN exposed pad (TAB) must be connected to the ground plane underneath. The use of multiple via improves the package heat dissipation.

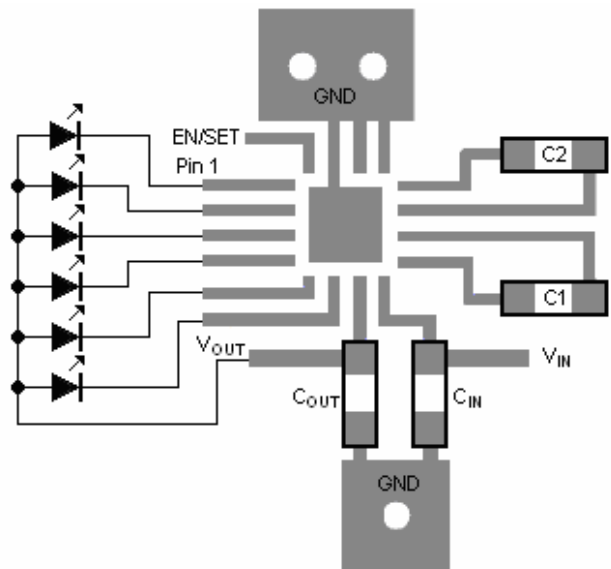
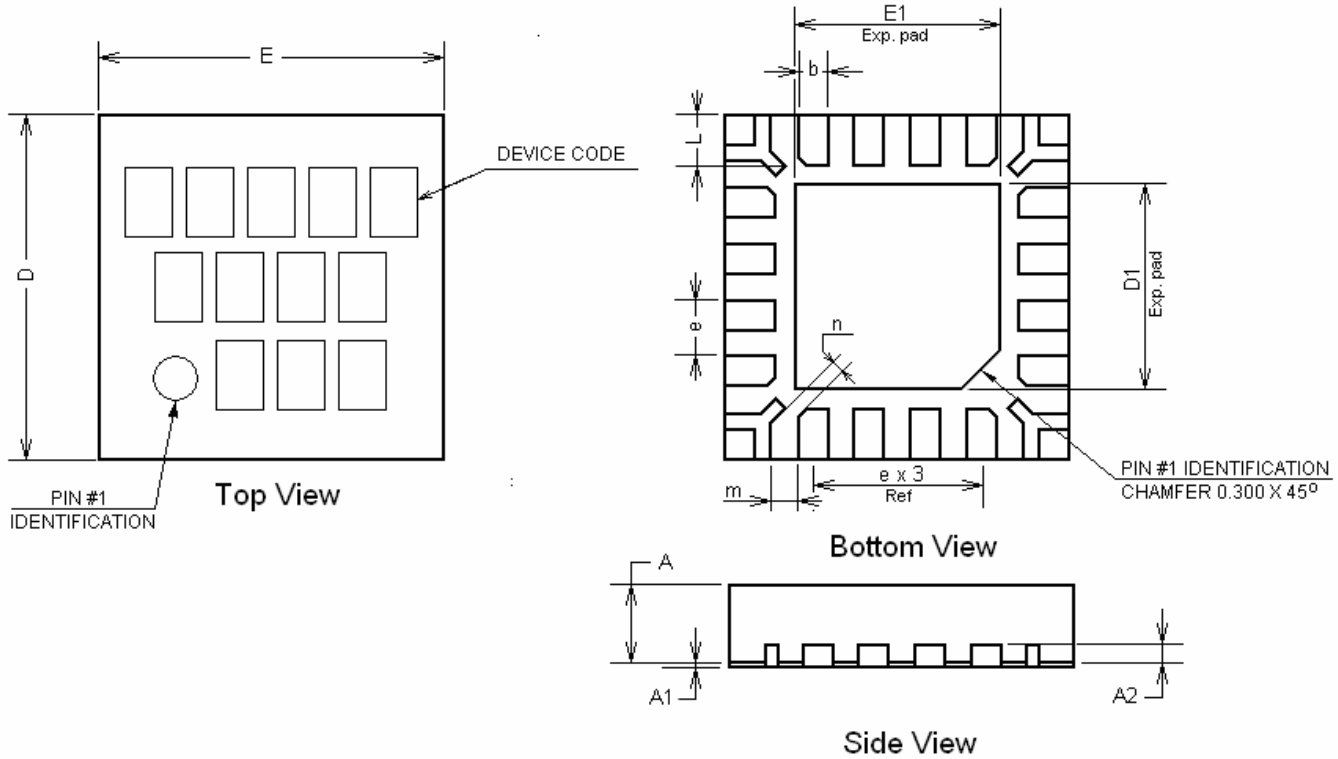

Figure 4. Recommended layout

PACKAGE DRAWING AND DIMENSIONS

16-PIN TQFN (HV3), 3mm x 3mm, 0.5mm PITCH



SYMBOL	MIN	NOM	MAX
A	0.70	0.75	0.80
A1	0.00	0.02	0.05
A2	0.178	0.203	0.228
b	0.20	0.25	0.30
D	2.95	3.00	3.05
D1	1.65	1.70	1.75
E	2.95	3.00	3.05
E1	1.65	1.70	1.75
e		0.50 typ	
L	0.325	0.375	0.425
m		0.150 typ	
n		0.225 typ	

Note:

1. All dimensions are in millimeters
2. Complies with JEDEC Standard MO-220

ORDERING INFORMATION

Part Number	Package	Package Marking
LDS8869 002-T2	TQFN-16 3 x 3mm ⁽¹⁾	8869

Notes:

1. Matte-Tin Plated Finish (RoHS-compliant)
2. Quantity per reel is 2000

EXAMPLE OF ORDERING INFORMATION

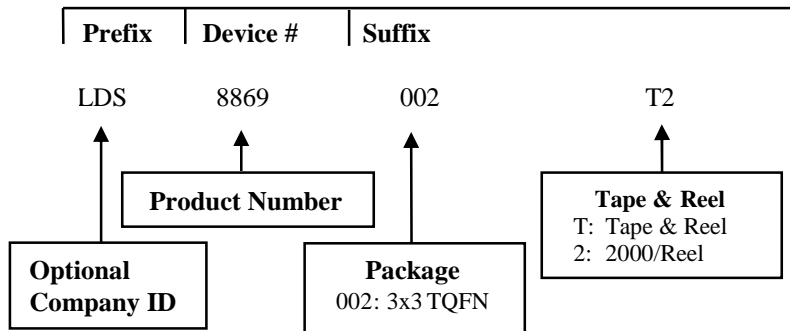

Notes:

- 1) All packages are RoHS-compliant (Lead-free, Halogen-free).
- 2) The standard lead finish is Matte-Tin.
- 3) The device used in the above example is a LDS8869 002-T2 (3x3 TQFN, Tape & Reel).
- 4) For additional package and temperature options, please contact your nearest Leadis Technology Sales office.

Warranty and Use

LEADIS TECHNOLOGY MAKES NO WARRANTY, REPRESENTATION OR GUARANTEE, EXPRESS OR IMPLIED, REGARDING THE SUITABILITY OF ITS PRODUCTS FOR ANY PARTICULAR PURPOSE, NOR THAT THE USE OF ITS PRODUCTS WILL NOT INFRINGE ITS INTELLECTUAL PROPERTY RIGHTS OR THE RIGHTS OF THIRD PARTIES WITH RESPECT TO ANY PARTICULAR USE OR APPLICATION AND SPECIFICALLY DISCLAIMS ANY AND ALL LIABILITY ARISING OUT OF ANY SUCH USE OR APPLICATION, INCLUDING BUT NOT LIMITED TO, CONSEQUENTIAL OR INCIDENTAL DAMAGES.

Leadis Technology products are not designed, intended, or authorized for use as components in systems intended for surgical implant into the body, or other applications intended to support or sustain life, or for any other application in which the failure of the Leadis Technology product could create a situation where personal injury or death may occur.

Leadis Technology reserves the right to make changes to or discontinue any product or service described herein without notice. Products with data sheets labeled "Advance Information" or "Preliminary" and other products described herein may not be in production or offered for sale.

Leadis Technology advises customers to obtain the current version of the relevant product information before placing orders. Circuit diagrams illustrate typical semiconductor applications and may not be complete.



Leadis Technology
800 W. California Ave,
Suite 200
Sunnyvale, CA 94086
Phone: 408.331.8600
Fax: 408.331.8601
<http://www.leadis.com>

Document No: 8869_DS
Revision: 2.1
Issue date: 12/2/2008