

## 4-Channel Ultra Low Dropout No Noise LED Driver

### FEATURES

- Ultra-low dropout PowerLite™ Current Regulator\*
- Drives up to 4 LEDs at 30 mA each
- PWM brightness control
- Power efficiency >95%
- Low input noise & ripple
- Low current shutdown mode
- Load disconnect in shutdown mode
- Short circuit protection
- Thermal shutdown protection
- Available in 3 x 3 x 0.8 mm and 4 x 4 x 0.8 mm 16-pin TQFN packages

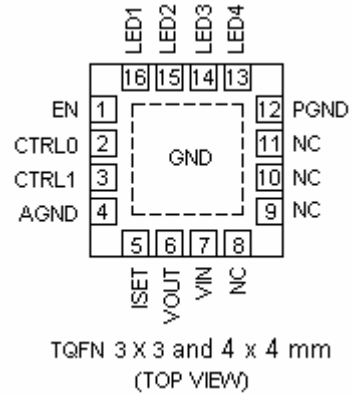

LED current is easily adjustable by an external resistor up to 30 mA per channel.

The CTRL0 and CTRL1 logic inputs function as a LED enable and a PWM mode LED brightness control.

The driver supports a wide range of input voltages from 2.7 V to 5.5 V.

The thermal and short circuit protection guarantee high device reliability.

The device is available in a 16-pin TQFN 3 x 3 mm and 4 x 4 mm packages with a max height of 0.8 mm.

### APPLICATION

- Keypad and Display Backlight
- Cellular Phones
- Digital Still Cameras
- PDAs and Smartphones

### DESCRIPTION

The LDS8845 is a high efficiency ultra-low dropout current regulator that can drive up to four LEDs. The

### TYPICAL APPLICATION CIRCUIT

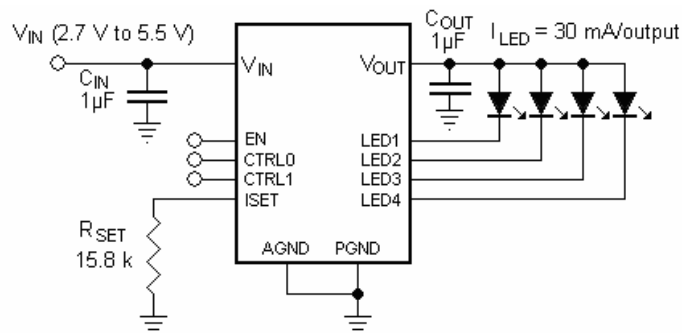

## ABSOLUTE MAXIMUM RATINGS

Parameter	Rating	Unit
V <sub>IN</sub> , LEDx voltage	-0.3 to 6	V
V <sub>OUT</sub> voltage	-0.3 to 6	V
EN, CTRL0, CTRL1 voltage	V <sub>IN</sub> + 0.7V	V
Storage Temperature Range	-65 to +150	°C
Junction Temperature Range	-40 to +125	°C
Soldering Temperature (10s)	300	°C
ESD protection HBM	2	kV

**NOTE:** Stresses listed above may cause permanent damage to the device. Functional operation of the device at these or any other conditions beyond those indicated in the "Recommended Operating Conditions" is not implied. Exposure to absolute maximum rating conditions for extended periods may remain possible to affect device reliability.

## RECOMMENDED OPERATING CONDITIONS

Parameter	Rating	Unit
V <sub>IN</sub>	2.7 to 5.5	V
Ambient Temperature Range	-40 to +85	°C

## ELECTRICAL OPERATING CHARACTERISTICS

(Over recommended operating conditions unless specified otherwise) V<sub>IN</sub> = 3.6V, EN = High, T<sub>AMB</sub> = 25°C

Name	Conditions	Min	Typ	Max	Units	
Quiescent Current	I <sub>LED</sub> = 20mA per channel		1.3	1.5	mA	
Shutdown Current	EN = 0V		0.1	1	µA	
LED Current	R <sub>SET</sub> = 24k		20		mA	
	R <sub>SET</sub> = 96k		5			
LED Current Setting Range	2.7 < V <sub>IN</sub> < 5.5V	2		30	mA	
LED Current Accuracy	To set value	-8	3	+8	%	
LED Channel Matching	(I <sub>LED MAX</sub> - I <sub>LED MIN</sub> ) / (I <sub>LED MAX</sub> + I <sub>LED MIN</sub> )	-5	3	+5	%	
Current Sink Dropout Voltage*			20	30	mV	
Short Circuit Output Current Limit	V <sub>OUT</sub> = 0V		22	25	mA	
EN, CTRL0, CTRL1 pins	Leakage Current	High	Input Voltage = V <sub>IN</sub>		1	µA
		Low	Input Voltage = 0	-1		
	Logic Level Threshold	High		1.3		V
		Low			0.4	
PWM frequency		100		100000	Hz	
PWM duty cycle		1		100	%	
Thermal Shutdown			150		°C	
Thermal Hysteresis			20			
Under Voltage Lockout (UVLO)			2.4		V	

\*) Voltage drop at led pin, at which LED current falls 10% below set value

## CONTROL INPUTS FUNCTION

Control Inputs		Output States			
CTRL1	CTRL0	LED4	LED3	LED2	LED1
0	0	OFF	OFF	ON	ON
0	1	OFF	ON	ON	ON
1	0	ON	ON	ON	ON
1	1	OFF	OFF	OFF	OFF

## TYPICAL CHARACTERISTICS

$V_{IN} = 3.6V$ ,  $I_{OUT} = 104\text{ mA}$  (4 LEDs at 26 mA each),  $C_{IN} = C_{OUT} = 1\text{ }\mu\text{F}$ ,  $V_f = 3.2\text{ V}$ ,  $T_{AMB} = 25\text{ }^\circ\text{C}$

**Power Efficiency vs. Input Voltage**

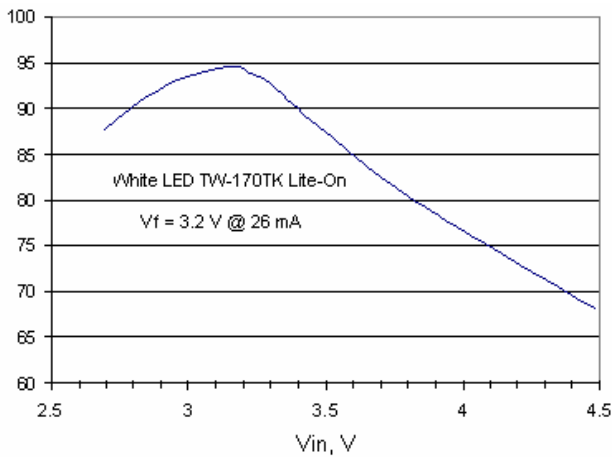

**LED Current vs. Temperature**

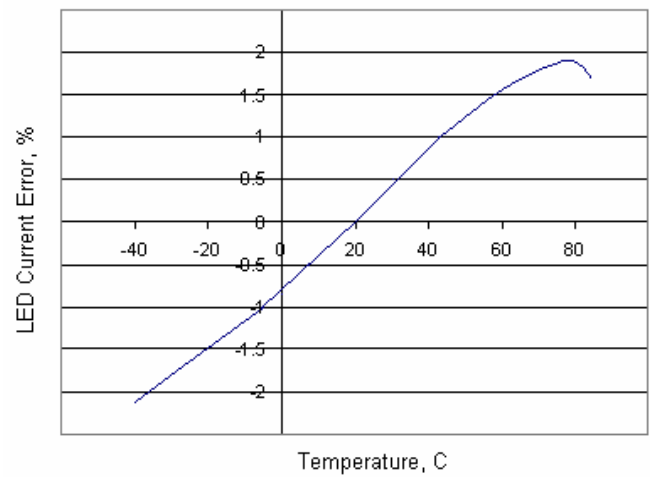

**LED Current vs. Input Voltage**

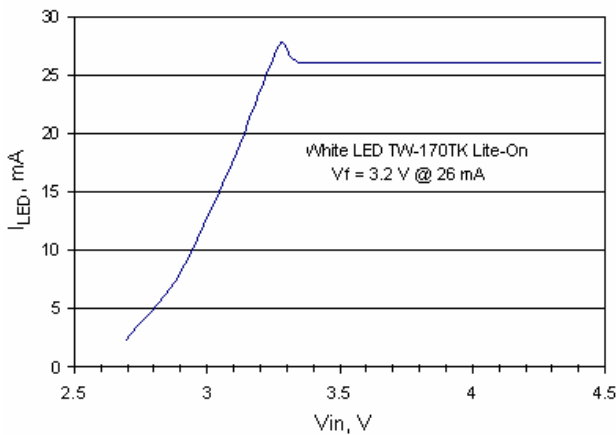

**Power-Up Delay Time**

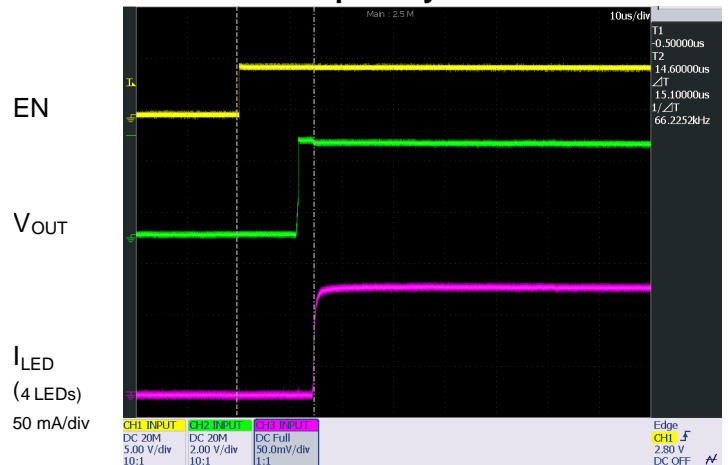

### Power-Down Delay Time

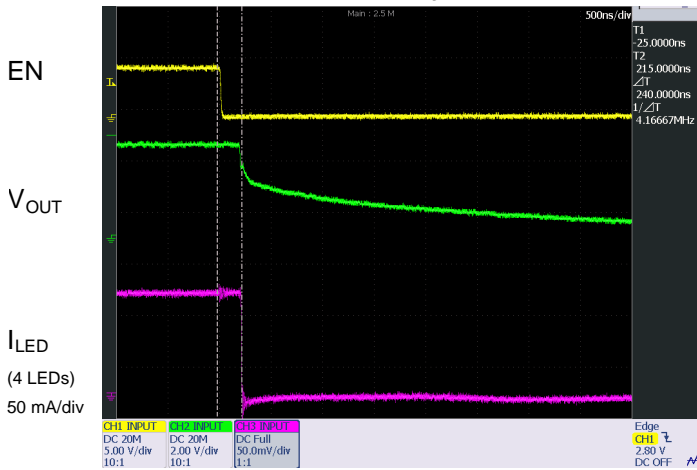

### PWM Mode (1 kHz, 50 Duty Cycle)

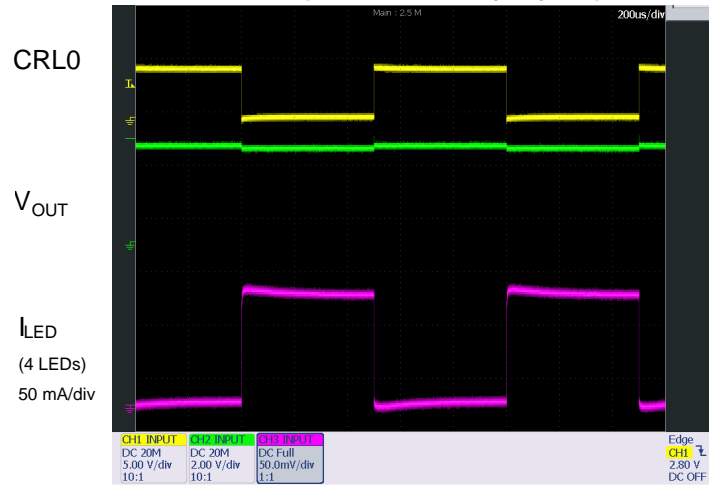

### PWM Mode (10 kHz, 50 Duty Cycle)

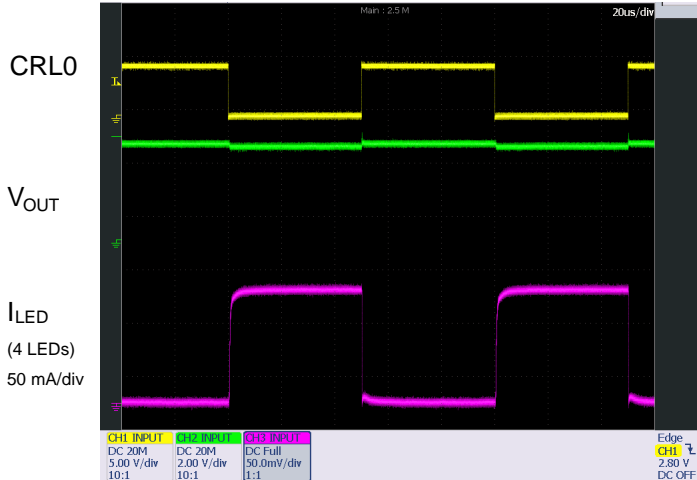

### PWM Mode (50 kHz, 50 Duty Cycle)

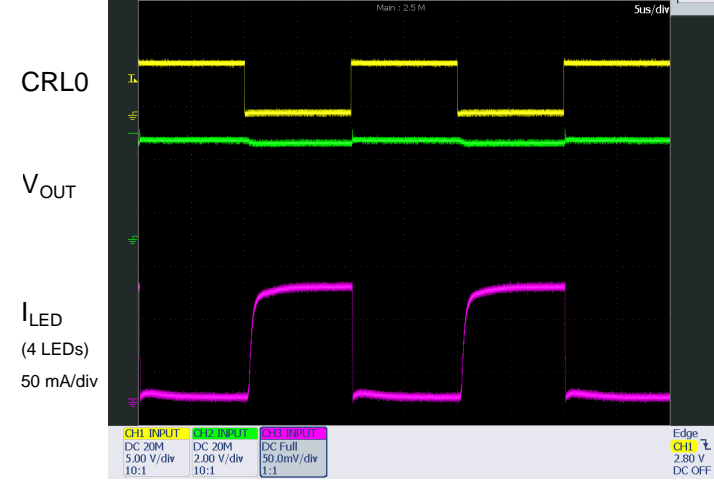

### I<sub>LED</sub> Current vs. Duty Cycle

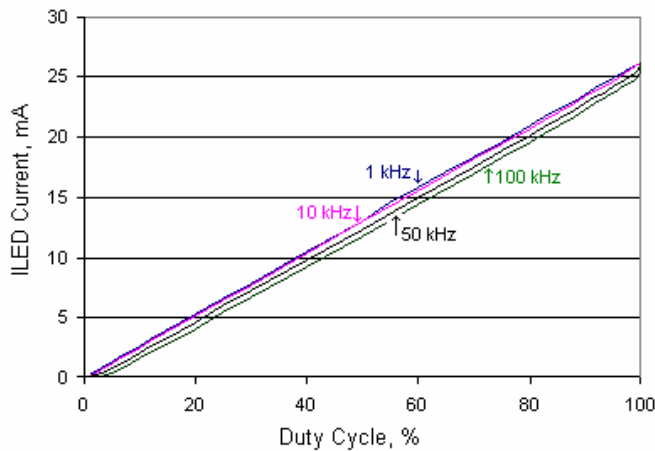

### I<sub>LED</sub> Current Error vs. Duty Cycle

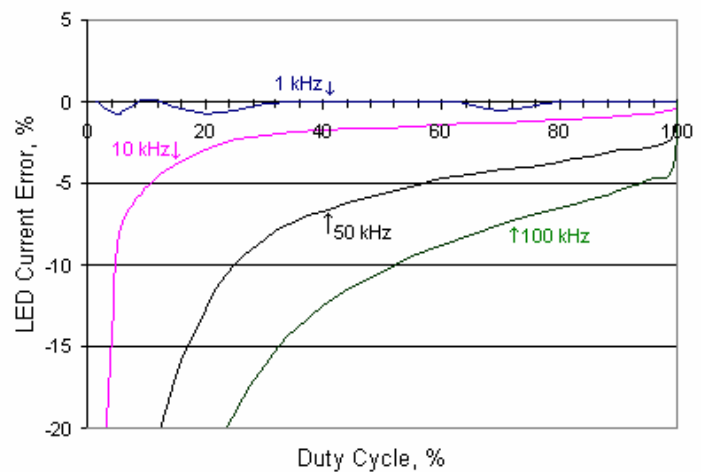

## PIN DESCRIPTION

Pin #	Name	Function
1	EN	Device Enable.
2	CTRL0	Output Control Bit 0 (See Table Control Pin Function)
3	CTRL1	Output Control Bit 1 (See Table Control Pin Function)
4	AGND	Analog ground
5	ISET	LED current setting pin
6	V <sub>OUT</sub>	Output voltage to the LED anodes
7	V <sub>IN</sub>	Input Voltage
8 - 11	NC	No internal connect
12	PGND	Power Ground
13	LED4	LED4 Cathode Terminal
14	LED3	LED3 Cathode Terminal
15	LED2	LED2 Cathode Terminal
16	LED1	LED1 Cathode Terminal
PAD	PAD	Connect to GND on the PCB

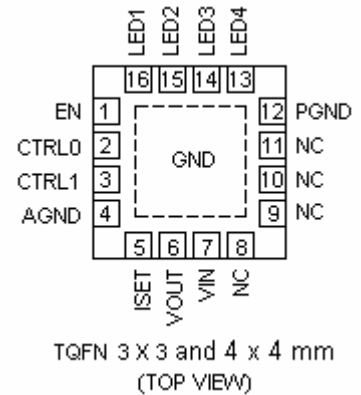

## PIN FUNCTION

**EN** is a Device Enable. This pin is high impedance. There should be a pull down resistor <100k when control signal is floating.

**CTRL0, CTRL1** are Output Control Bits 0/1 (See Table 2) and PWM LED brightness control logic inputs. Guaranteed levels of logic high and logic low are set at 1.3 V and 0.4 V respectively. These pins are high impedance. There should be a pull down resistors <100k when control signal is floating.

**ISET** is a LED current setting pin. Resistor R<sub>SET</sub> connected from this pin to ground controls LED current. Do not short this pin to ground directly.

**V<sub>IN</sub>** is the device supply pin. A small 1 $\mu$ F ceramic bypass capacitor recommended between the V<sub>IN</sub> pin and ground at the device. The operating input voltage range is from 2.7 V to 5.5 V. Whenever the input supply falls below the under-voltage threshold (2.2 V), all the LED channels are disabled, and the device enters shutdown mode.

**V<sub>OUT</sub>** is the driver output. Connect it to the LED anodes. A small 1 $\mu$ F ceramic bypass capacitor recommended between the V<sub>OUT</sub> pin and ground near the device. This pin is at high-impedance state in shutdown mode.

**AGND** is the ground reference for the internal device circuitry. Connect R<sub>SET</sub> to this pin. Teed AGND and PGND pins together on PCB.

**PGND** is the current regulators ground current source. Connect this pin to the ground plane on the PCB and teed to AGND pin as close to the package as possible.

**LED1 – LED4** provide the internal regulated current sink for each of the LED cathodes. These pins enter a high-impedance state when the device is in shutdown mode.

**PAD** is the exposed pad underneath the package. For best thermal performance, the pad should be soldered to the PCB and connected to the ground plane

## BLOCK DIAGRAM

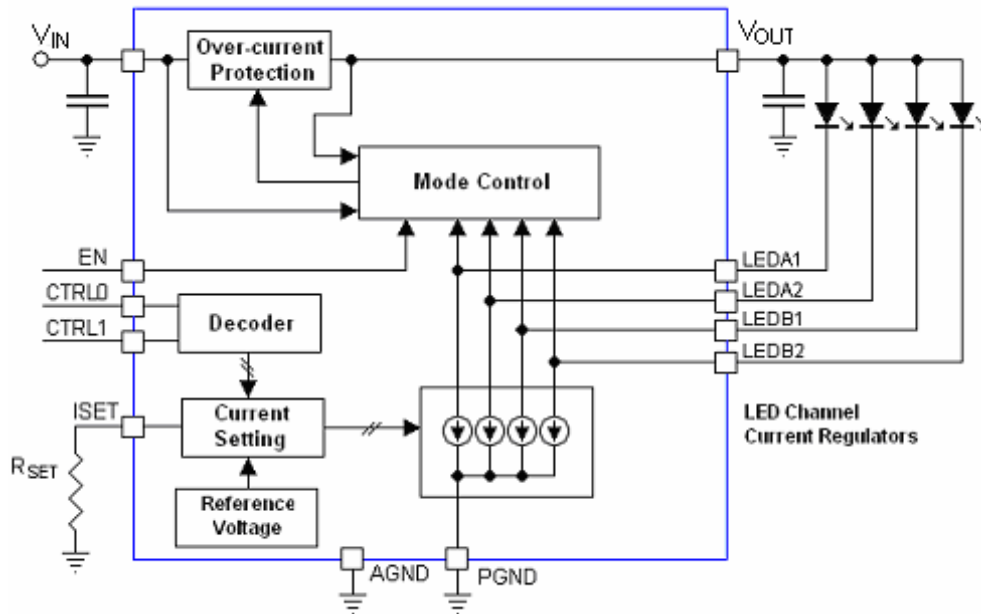

Figure 2. LDS8845 Functional Block Diagram

## BASIC OPERATION

The device starts operating if the EN pin is set logic HIGH and input voltage is higher than under voltage protection lockout threshold.

The low dropout PowerLite™ Current regulator performs well at input voltages up to 50 mV greater than the LED forward voltage significantly increasing the driver's efficiency.

Input pins EN, CTRL0, and CTRL1 may be either logic LOW or HIGH during power-up. However, logic voltage should never exceed input voltage  $V_{IN}$ , and these pins should not be left float.

### LED Current Setting

The desired current value in each of the four LED is set by external resistor  $R_{SET}$  connected between  $I_{SET}$  pin and ground.

The LED current is 400 times greater than the current through  $R_{SET}$  and can be estimated by following equation:

$$I_{LED} = 400 \times \frac{V_{SET}}{R_{SET}}, \text{ where } V_{SET} = 1.2V, \text{ and } R_{SET} \text{ is}$$

its resistance.

$R_{SET}$  value for typical  $I_{LED}$  current is shown at the table below.

$I_{LED}$ , mA	$R_{SET}$ , k $\Omega$	Nearest standard 1% value
5	96	95.3
10	48	47.5
15	32	31.6 or 32.4
20	24	23.7 or 24.3
25	19.2	19.1
30	16	15.8 or 16.2

The average current value may be decreased using PWM signal applied to either CTRL0 or CTRL1 pin. LDS8845 allows modulation frequencies in the range from 100 Hz to 10 kHz with duty cycles from 100% to 1%. Modulation frequencies lower than 100 Hz are not recommended especially at short duty cycles because LED flicker may be visible.

If CTRL1 pin is logic HIGH and PWM signal applies to CTRL0 pin, then all four LEDs are dimming synchronously.

If CTRL0 pin is logic HIGH and PWM signal applies to CTRL1 pin, then LEDs from LED1 to LED3 are dimming, while LED4 is always off.

If PWM signal applies to both CTRL pins tied together, then LED1 and LED2 are dimming, while LED3 and LED4 are off.

## Unused LED Channels

For applications with only two or three LEDs, unused LED can be disabled via the appropriate CTRL pins logic states. For applications requiring 1 LED only, the unused LED pins should be tied to  $V_{OUT}$ . However, we recommend use of all channels connecting them in parallel with accordingly decreased current per channel. If one LED is used only, current per channel should be decreased four times, or this device may drive one LED with maximum current up to 120 mA with all channels connected in parallel and 30 mA current per channel.

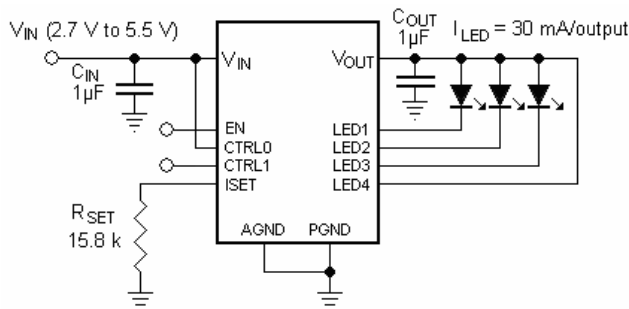

Figure 3. Application circuit with three LEDs

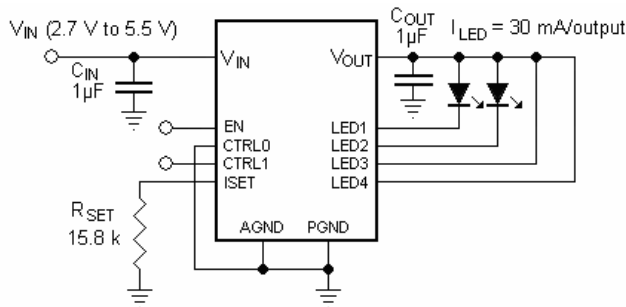

Figure 4. Application circuit with two LEDs

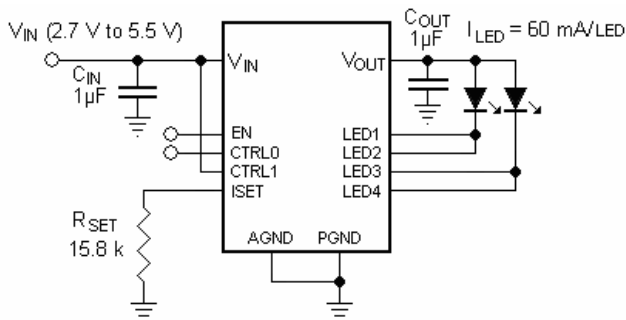

Figure 5. Application circuit with two LEDs

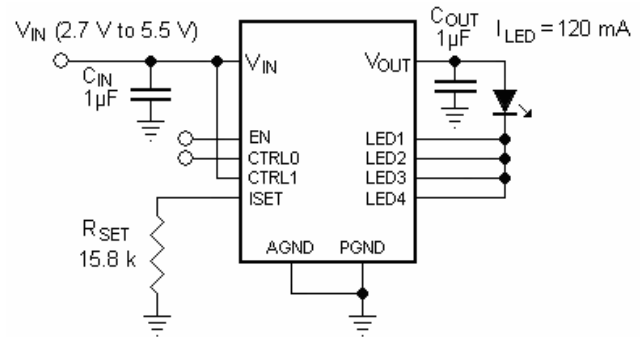

Figure 6. Application circuit with one LED

## Protection Mode

The LDS8845 limits output current if  $V_{OUT}$  pin is shorted to ground either before or after device start. This is to prevent the device from overload in case of short circuit at the output. Device resumes normal operation after short removed.

If the die temperature exceeds  $+150^{\circ}\text{C}$ , the driver will enter thermal protection shutdown mode. When the device temperature drops by about  $20^{\circ}\text{C}$ , the device will resume normal operation.

If the input voltage is below under-voltage protection threshold, device turns into shutdown mode with high impedance state at  $V_{OUT}$  and all LED pins.

## LED Selection

LEDs with forward voltages ( $V_F$ ) ranging from 1.3 V to 4.5 V may be used. The device exhibits the highest efficiency when  $V_F$  voltage is close to  $V_{IN}$ . If the voltage source is a Li-ion battery, we recommend selecting LEDs with  $V_F$  at least 50 mV below minimum expected battery discharging voltage to extend the battery life and achieve highest efficiency.

If the minimum battery discharging voltage is limited at 3 V, recommended  $V_F$  voltage is  $V_F = 3.0 - 0.05 = 2.95$  V

## External Components

The driver requires only one external component – current setting resistor  $R_{SET}$ . However, if device is connected to the voltage source (battery) through long traces, or voltage source has high electrical noise due bad performance of other components connected to this source, we recommend 1µF decoupling capacitors at the  $V_{IN}$  and  $V_{OUT}$  pins located as close to the device as possible.

Power dissipates on  $R_{SET}$  resistor is less than  $100\mu\text{W}$  that allows use of very small surface mount component.

## Recommended Layout

It is recommended to minimize trace length to decoupling capacitors. A ground plane should cover the area under the driver IC as well as the bypass capacitors. Short connection to ground on capacitors  $C_{IN}$  and  $C_{OUT}$  can be implemented with the use of multiple vias. A copper area matching the TQFN exposed pad (PAD) must be connected to the ground plane underneath. The use of multiple via improves the package heat dissipation.

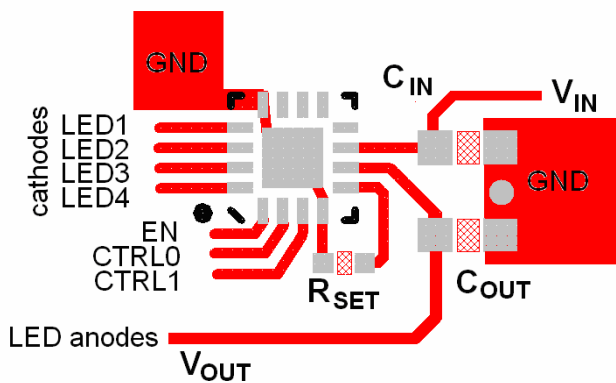
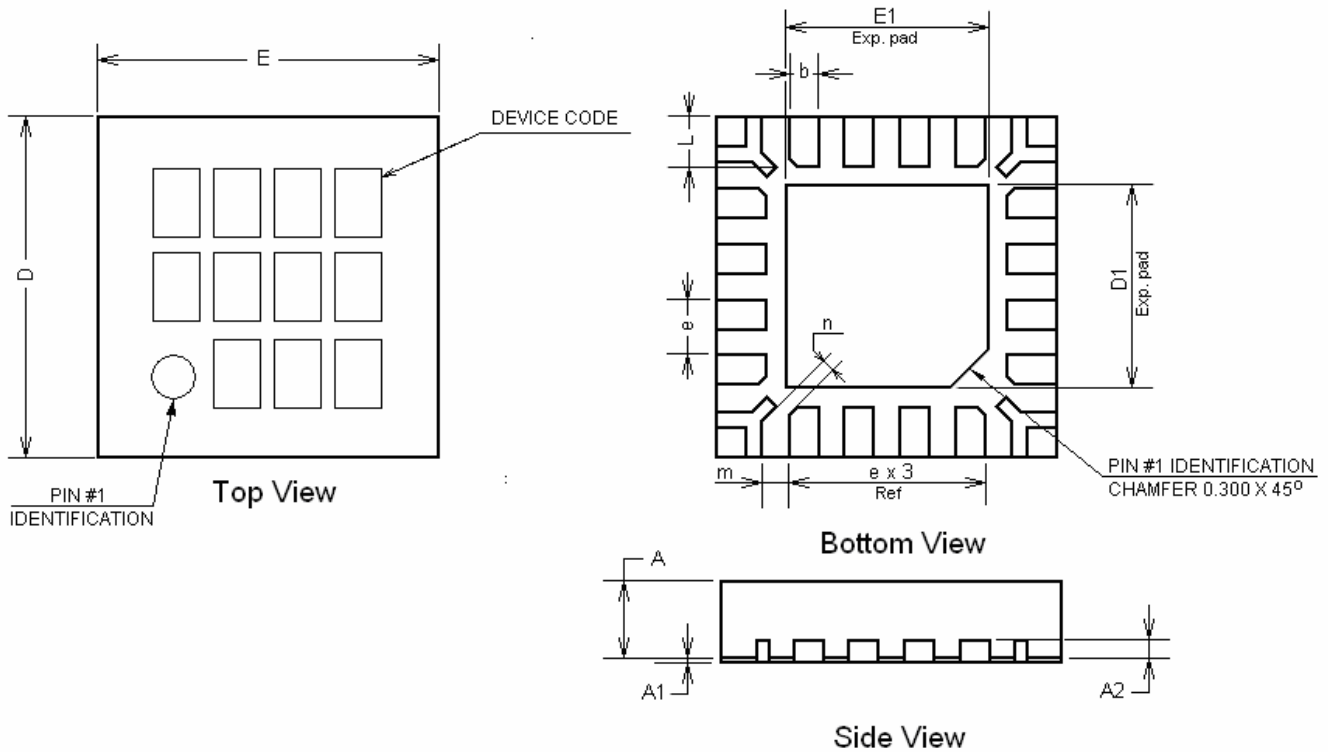

Figure 7. Recommended layout



## PACKAGE DRAWING AND DIMENSIONS

16-PIN TQFN (HV3), 3mm x 3mm, 0.5mm PITCH



SYMBOL	MIN	NOM	MAX
A	0.70	0.75	0.80
A1	0.00	0.02	0.05
A2	0.178	0.203	0.228
b	0.20	0.25	0.30
D	2.95	3.00	3.05
D1	1.65	1.70	1.75
E	2.95	3.00	3.05
E1	1.65	1.70	1.75
e		0.50 typ	
L	0.325	0.375	0.425
m		0.150 typ	
n		0.225 typ	

**Note:**

1. All dimensions are in millimeters
2. Complies with JEDEC Standard MO-220

## 16-PIN TQFN, 4mm x 4mm, 0.65mm PITCH

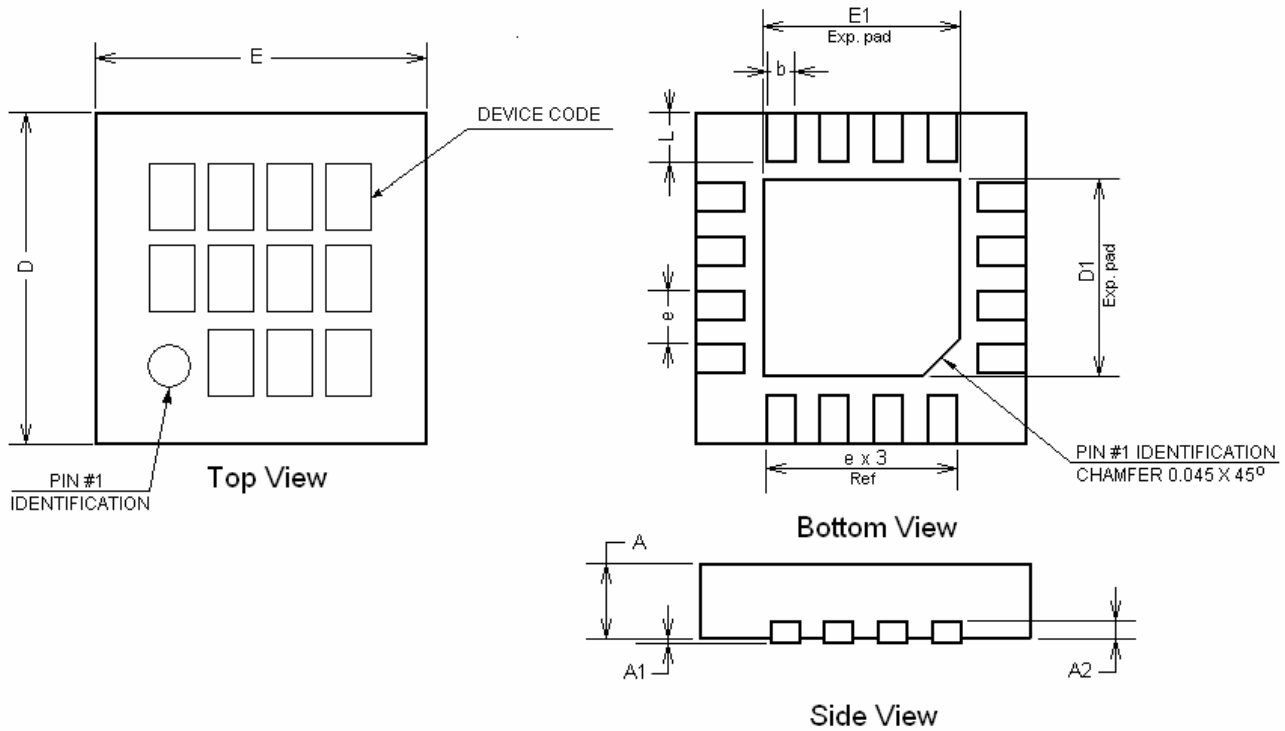

SYMBOL	MIN	NOM	MAX
A	0.70	0.75	0.80
A1	0.00	0.02	0.05
A2	0.178	0.203	0.228
b	0.28	0.33	0.38
D	3.90	4.00	4.10
D1	2.35	2.40	2.45
E	3.90	4.00	4.10
E1	2.35	2.40	2.45
e		0.65 typ	
L	0.55	0.60	0.65

**Note:**

- All dimensions are in millimeters
- Complies with JEDEC Standard MO-220

1.

## ORDERING INFORMATION

Part Number	Package	Package Marking
LDS8845 002 -T2	TQFN-16 3 x 3mm	8845
LDS8845 003 -T2	TQFN-16 4 x 4mm	8845

**Notes:**

1. Matte-Tin Plated Finish (RoHS-compliant)
2. Quantity per reel is 2000

## EXAMPLE OF ORDERING INFORMATION

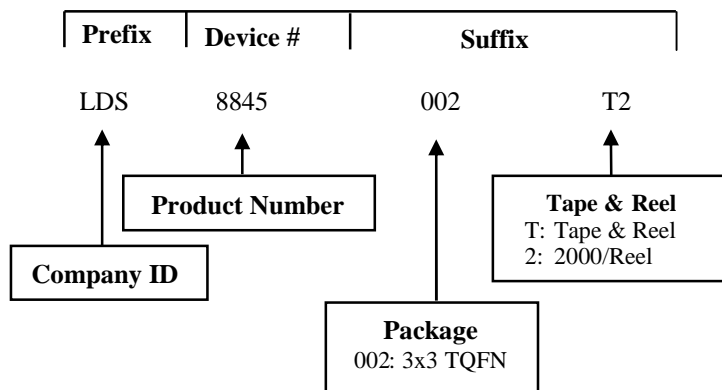

**Notes:**

- 1) All packages are RoHS-compliant (Lead-free, Halogen-free).
- 2) The standard lead finish is Matte-Tin.
- 3) The device used in the above example is a LDS8845 002-T2 (3x3 TQFN, Tape & Reel, 32/25/10.5 mA maximum current per LED bank).
- 4) For additional package and temperature options, please contact your nearest Leadis Technology Sales office.

---

## Warranty and Use

*LEADIS TECHNOLOGY MAKES NO WARRANTY, REPRESENTATION OR GUARANTEE, EXPRESS OR IMPLIED, REGARDING THE SUITABILITY OF ITS PRODUCTS FOR ANY PARTICULAR PURPOSE, NOR THAT THE USE OF ITS PRODUCTS WILL NOT INFRINGE ITS INTELLECTUAL PROPERTY RIGHTS OR THE RIGHTS OF THIRD PARTIES WITH RESPECT TO ANY PARTICULAR USE OR APPLICATION AND SPECIFICALLY DISCLAIMS ANY AND ALL LIABILITY ARISING OUT OF ANY SUCH USE OR APPLICATION, INCLUDING BUT NOT LIMITED TO, CONSEQUENTIAL OR INCIDENTAL DAMAGES.*

Leadis Technology products are not designed, intended, or authorized for use as components in systems intended for surgical implant into the body, or other applications intended to support or sustain life, or for any other application in which the failure of the Leadis Technology product could create a situation where personal injury or death may occur.

Leadis Technology reserves the right to make changes to or discontinue any product or service described herein without notice. Products with data sheets labeled "Advance Information" or "Preliminary" and other products described herein may not be in production or offered for sale.

Leadis Technology advises customers to obtain the current version of the relevant product information before placing orders. Circuit diagrams illustrate typical semiconductor applications and may not be complete.

---



Leadis Technology  
800 W. California Ave,  
Suite 200  
Sunnyvale, CA 94086  
Phone: 408.331.8600  
Fax: 408.331.8601  
<http://www.leadis.com>

Document No: 8845DS  
Revision: 1.5  
Issue date: 9/19/2008