

1. SCOPE

This specification describes the electrical, mechanical and environmental parameters for this battery pack consisting of a Lithium Ion cell 25.9V/ 9600 mAh, with protection safety circuit with gas gauge.

2. Dimensions:

- Thickness = 3.6''
- Width = 2.89''
- Length = 9.15''

3. Weight: 4.75 lb

4. Cell specification: Lithium- Ion Battery

4.1 Nominal voltage: 25.9V

4.2 Capacity: Nominal 9.6Ah at 25°C using:

- Charge profile of 29.4V
- Recommended charge current of 5000mA
- Charging time of 3 hrs or a taper current of 480mA (C/20)
- Discharge profile with a maximum current of 1920mA (C/5) to 17.5V

4.3 Charging the Battery:

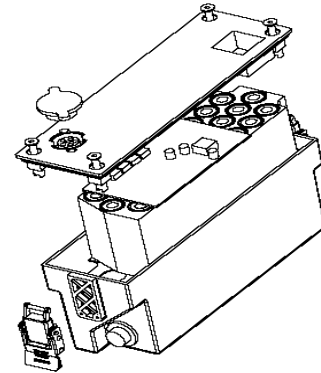

Lithium Ion Charging Characteristics

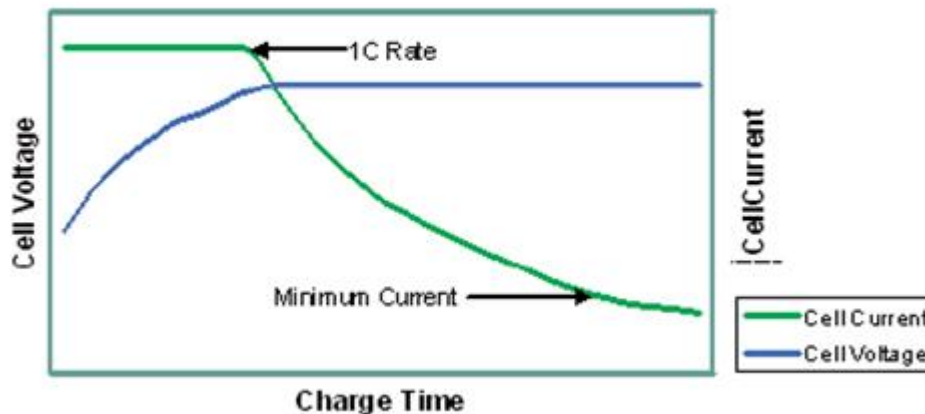

4.3.1 Charging Condition:

- CV of 29.4V max
- CC of 3.0A max.

| | | | |
|---|---|---|---|
| <u>REVISION</u> 00 | <u>ECR/ECN INFORMATION</u> EC No: DATE: | <u>TITLE:</u> 25.9V 9600mAh Li-Ion battery | <u>SHEET No.</u> 1 of 3 |
| <u>DOCUMENT NUMBER:</u> 990373D | | <u>CREATED/REVISED BY:</u> AIE | <u>CHECKED BY:</u> MJS <u>APPROVED BY:</u> MJS |

4.3.2 To charge lithium-ion battery packs please follow the charging instruction stated below:

Charging instructions

- Charge Voltage: Limit the maximum charge voltage to 4.2V times the number of cells connected in series. This charging voltage is noted on the product specification sheet.
- Charge current: Packs should be charged at C rate for lithium-ion cells. C is the nominal capacity of the pack. (Example: for a 2400 mAh cell, charge at 2.4A).
- Pre-charge: If the cells are deeply depleted (less than 2.9V per cell), packs should be charged at 10% of their capacity (Example: for a 2400 mAh cell, charge at 240 mA) until reaching 3.0V per cell when charging can be continued as stated above.
- Charge temperature: Do not charge lithium ion cells at less than 0°C or more than 45°C.
- Reverse polarity: When connecting the cells to a charger, verify proper polarity.
- Charge method: Lithium ion cells should be charged using a constant current/constant voltage (CC/CV) method. Apply the charge current as stipulated above in step 2 until the pack reaches the voltage measured in step 1. Then, hold the voltage constant until the current tapers down to about 5% of nominal capacity (Example: for a 2400 mAh cell, charge until current is 120 mA).

4.4 Discharge condition:

- Cutoff voltage of 21.0V
- Maximum continuous discharge current of 6000 mA.

4.5 Cycle life: 86% of initial minimum capacity after 300 cycles at 0.2C, 25°C

4.6 Temperature:

- Charge 0~45°C
- Discharge -40~60°C
- Storage 20~35°C

4.7 Products shipped have 40% state of charge typical

| | | | |
|---|---|---|--|
| <u>REVISION</u> 00 | <u>ECR/ECN INFORMATION</u> EC No: DATE: | <u>TITLE:</u> 25.9V 9600mAh Li-Ion battery | <u>SHEET No.</u> 2 of 3 |
| <u>DOCUMENT NUMBER:</u> 990373D | | <u>CREATED/REVISED BY:</u> AIE | <u>CHECKED BY:</u> MJS / <u>APPROVED BY:</u> MJS |

5. Protection Safety Circuit

- Main IC controller is Mitsumi MM1414CVBE
- Overcharge cutoff voltage: 4.350v +/-25mv
- Overdischarge cutoff voltage: 2.30v +/- 100mv
- Overcurrent detection will not occur below 16A and will occur above 20A
- Thermistor 10k ,5%
- Gold-Plated Contacts

6. Additional component

- Polyester Label
- Polycarbonate ABS Plastic Tray
- Polycarbonate ABS Plastic Cover
- Nomex, Kapton Tape, PVC Heat Shrink, or similar insulators

7. Storage temperature and Humidity range

- -20~20°C,45-85%RH (within 1year)
- -20~45°C,45-85%RH (within 3 month)
- -20~60°C,45-85%RH (within 1 month)

8. Storage cautions

- Do not store packs in places of high temperature or under direct sunlight
- For long term storage, store packs in 30% charge state.
- Do not store packs in place which may expose them to rain, water or high humidity.

| | | | |
|---|---|---|----------------------------------|
| <u>REVISION</u> 00 | <u>ECR/ECN INFORMATION</u> EC No: DATE: | <u>TITLE:</u> 25.9V 9600mAh Li-Ion battery | <u>SHEET No.</u> 3 of 3 |
| <u>DOCUMENT NUMBER:</u> 990373D | | <u>CREATED/REVISED BY:</u> AIE | <u>CHECKED BY:</u> MJS |
| | | <u>APPROVED BY:</u> MJS | |