



LIGHTING FOREVER

APS-12D-1-02/TR8

Surface - Mount Digital Ambient Light Sensor with Proximity Sensor

Features

Ambient light sensing

- 4 Selectable range: Range 1 = 0.24Lux to 1000Lux
Range 2 = 0.96Lux to 4000Lux
Range 3 = 3.84Lux to 16000Lux
Range 4 = 15.36Lux to 64000Lux
- Human eye type spectral response (IR rejection)
- 12-bit effective resolution
- Provides an output count proportional to ambient light over the full operating range

Proximity sensing

- IR LED driver can adjust current drive from 50mA to 6.25mA
- 12-bit effective resolution
- Storage temperature range from -40 to 100°C
- Operating temperature range from -40°C to 85°C
- Operating voltage range: 2.25V ~ 3.5V
- Size: 2.1mm (L) x 2.0mm (W) x 0.6mm (H)
- RoHS compliant and Pb Free package

Description

APS-12D-1-02/TR8 is a digital-output light sensor, combining two photodiodes and signal processing circuit on a single CMOS integrated circuit to provide light measurements over an effective 12-bit dynamic range with a response similar to that of human eye. The integrating conversion technique employed by the APS-12D-1-02/TR8 effectively eliminates the effect of flicker from AC-powered lamps, increasing the stability of the measurement. Connected with an infrared LED (IRED), the built-in proximity sensor can reveal the closeness of approaching/departing objects. This device is intended primarily for use in applications in which measurement of ambient light and proximity sensing is a must, such as laptop computers, PDAs, camcorders, and GPS systems.

Applications

- Detection of ambient light for controlling the backlighting of TFT LCD display
- Automatic residential and commercial lighting management
- Automatic contrast enhancement for electronic signboard
- Mobile phone, Notebook PC, Net PC, UMPC, GPS... etc.

Surface - Mount Digital Ambient Light Sensor with Proximity Sensor

Package Dimensions

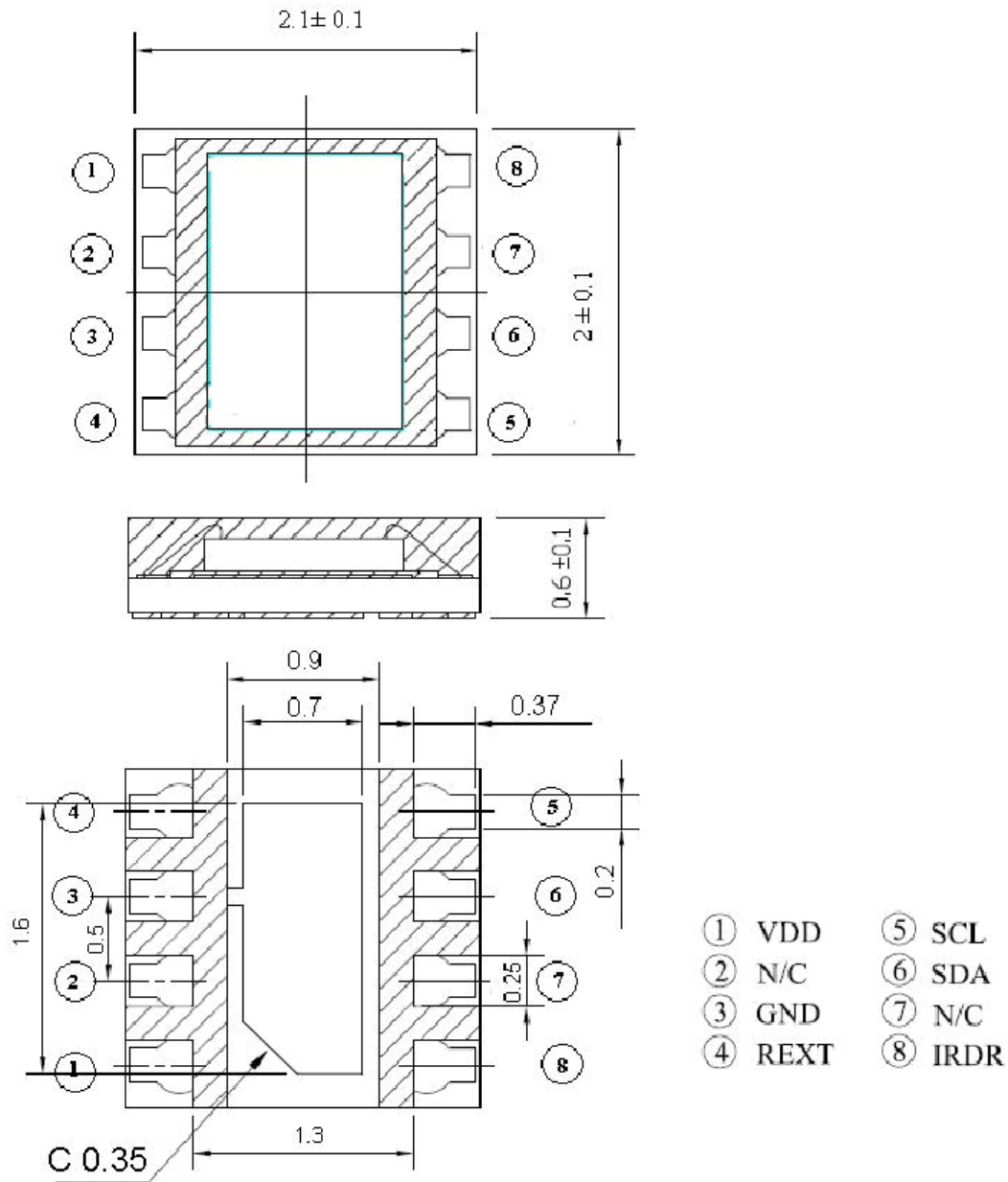

Unit: mm

Tolerances: ± 0.1 mm

Surface - Mount Digital Ambient Light Sensor with Proximity Sensor

PCB Pad Descriptions

PCB Soldering Pad

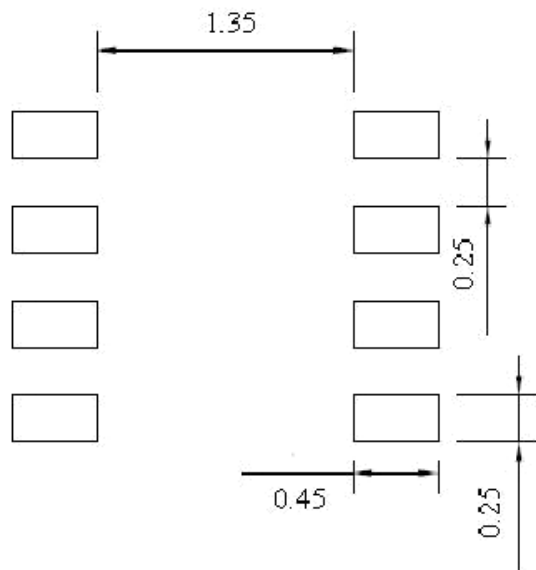

Absolute Maximum Ratings (Ta=25°C)

Parameter	Symbol	Min.	Max.	Unit
Storage temperature	TSTG	-40	100	°C
Operating temperature	TOPR	-40	85	°C
Supply voltage	V _{DD}	-0.3	5.0	V
Digital output voltage	V _o	-0.3	4.0	V
Digital output current	I _o	-10	+10	mA
ESD tolerance, human body model		2	-	KV

Surface - Mount Digital Ambient Light Sensor with Proximity Sensor

Block Diagram

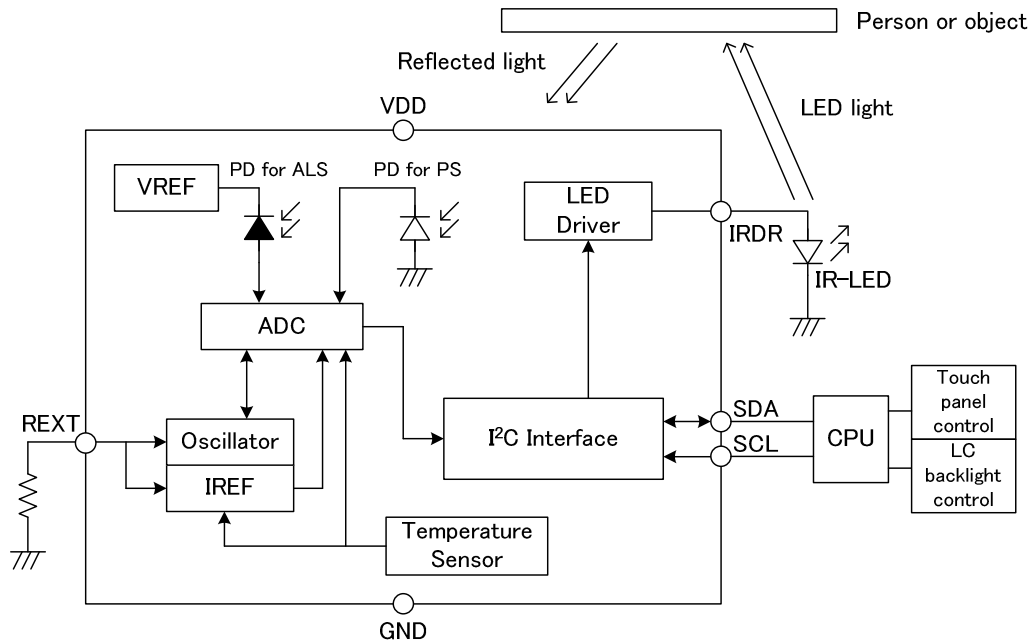

Figure 1. APS-12D-1-02/TR8 Block Diagram

Typical Application Circuit

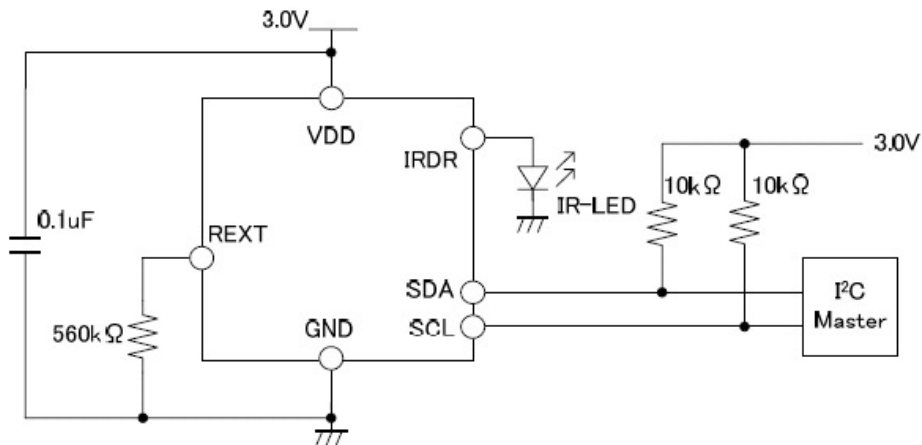

Figure 2. APS-12D-1-02/TR8 Typical Application Circuit



LIGHTING FOREVER

APS-12D-1-02/TR8

Surface - Mount Digital Ambient Light Sensor with Proximity Sensor

Electrical and Optical Characteristics (Ta=25°C , V_{op}=3.0 V)

Parameter	SYB	Test Conditions	Min.	Typ.	Max.	Unit
Operating Voltage	V _{op}		2.25		3.5	V
Supply Current	I _{dd1}	Supply current for ambient light sensing		70	90	μA
	I _{dd2}	Power shut down		0.1	1	μA
Internal Oscillator Frequency	fosc	Rext=560 KΩ	596	665	721	KHz
Reference Voltage	Vref			0.51		V
Dark Output	Data0	E=0 lux	0		3	Counts
Full Scale ADC Code	Data FS				4095	Counts
Prox Output 1 [Note 1.]	Data_IR1	Ee= 25uW/cm2, IR sensing Range 1	938	1250	1563	Counts
Prox Output 2 [Note 1.]	Data_IR2	Ee= 25uW/cm2, IR sensing Range 2		312		Counts
Prox Output 3 [Note 1.]	Data_IR3	Ee= 25uW/cm2, IR sensing Range 3		78		Counts
Prox Output 4 [Note 1.]	Data_IR4	Ee= 25uW/cm2, IR sensing Range 4		19		Counts
Count Output Variation		Ambient light sensing		5		%
light Count Output With LSB of 0.24lux/count [Note2.]	Data 1	E=300lux, Fluorescent light Range1(1k lux)	938	1250	1563	Counts
light Count Output With LSB of 0.96lux/count [Note2.]	Data 2	E=300lux, Fluorescent light Range2(4k lux)		312		Counts
light Count Output With LSB of 3.84lux/count [Note2.]	Data 3	E=300lux, Fluorescent light Range3(16k lux)		78		Counts
light Count Output With LSB of 15.36lux/count [Note2.]	Data 4	E=300lux, Fluorescent light Range4(64k lux)		19		Counts



LIGHTING FOREVER

APS-12D-1-02/TR8

Surface - Mount Digital Ambient Light Sensor with Proximity Sensor

Parameter	SYB	Test Condition	Min.	Typ.	Max.	Unit
IRDR Source Current 1 [Note.3]	IRDRI1	IS<0:0>=0	40	50	60	mA
IRDR Source Current 2 [Note.3]	IRDRI2	IS<0:1>=1		25		mA
IRDR Source Current 3 [Note.3]	IRDRI3	IS<1:0>=2		12.5		mA
IRDR Source Current 4 [Note.3]	IRDRI4	IS<1:1>=3		6.25		mA
IR Drive Pin Output Voltage	V _{IR}	IIRLED=50mA	V _{cc} -0.4		V _{cc}	V
IRDR rise time	t _r			35		ns
IRDR fall time	t _f			10		ns
IR DR output frequency 0	IRDRf0			DC		KHz
IR DR output frequency 3	IRDRf3			40.96		KHz
Data update time	T	12-bit ADC data		52.5		ms
Clock frequency	F ² C				400	KHz
Input voltage L	VIL				0.6	V
Input voltage H	VIH		1.5			V
SDA low level output voltage	VoL	SDA sink 3mA	0		0.4	V
High level input current	IIH		-10		10	μA
Low level input current	IIL		-10		10	μA
Data transfer wait time	tBUF		1.3		10	μs
SCL start hold time	tHD;DAT		0.6			μs
SCL low level hold time	tLow		100			ns
SCL High level hold time	tHigh		0.6			μs
Start condition setup time	Tsu;STA		0.6			μs
SDA data setup time	tHD;DAT		0.6			μs

Note:

1. 850nm IR LED is used in production test.
2. White Fluorescent light (Color Temperature = 6500K) is used as light source. However, White LED is substituted in mass production.
3. See "Register Set" on page 7 & 8.

Surface - Mount Digital Ambient Light Sensor with Proximity Sensor

Register structure

(1) 00h (Command 1) – ALS/PS Operating Mode Select

ST	Slave address								R/W	A	Sub address								A	Command 1								SP
	1	0	0	0	1	0	0	0	0		0	0	0	0	0	0	0	0		0	0	0	0	0	0	0	0	

OP2-OP0 : Operating mode select

OP2	OP1	OP0	Operating mode
0	0	0	Power-down the device
0	0	1	ALS once
0	1	0	Surrounding IR ones
0	1	1	Proximity once
1	0	0	(Reserved)
1	0	1	ALS continuous
1	1	0	Surrounding IR continuous
1	1	1	Proximity continuous

(2) 01h (Command 2) – ALS/PS IRDR & Modulation Frequency & Range Select

ST	Slave address								R/W	A	Sub address								A	Command 1								SP
	1	0	0	0	1	0	0	0	0		0	0	0	0	0	0	1	IS1		IS0	FREQ1	FREQ0	RES1	RES0	RANGE1	RANGE0		

IS1-IS0 : IRDR select

IS1	IS0	IRDR pin source current
0	0	50mA
0	1	25mA
1	0	12.5mA
1	1	6.25mA

FREQ1-FREQ0 : Modulation frequency select

FREQ1	FREQ0	Modulation frequency
0	0	DC
0	1	N/A
1	0	N/A
1	1	40.96kHz



LIGHTING FOREVER

APS-12D-1-02/TR8

Surface - Mount Digital Ambient Light Sensor with Proximity Sensor

RES1-RES0 : Resolution select (12bit only)

RES1	RES0	n-bit ADC
0	0	12
0	1	12
1	0	12
1	1	12

RANGE1-RANGE0 : Range select

RANGE1	RANGE0	FSR@ALS	FSR@IR sensing
0	0	1000	4095
0	1	4000	4095
1	0	16000	4095
1	1	64000	4095

(3) 02h (Data LSB) — ALS/APS Data Read Mode for Least Significant Bit (LSB)

ST	Slave address								R/W	A	Register address								ST	Slave address								R/W	A	Data (LSB)								SP
	1	0	0	0	1	0	0	0			0	0	0	0	0	0	1	0		1	0	0	0	1	0	0	0			D7	D6	D5	D4	D3	D2	D1	D0	
	1	0	0	0	1	0	0	0	0	0	0	0	0	0	0	1	0	1	0	0	0	1	0	0	0	1												

- ※ D0 is LSB for 12-bit resolution
- ※ R/W Format — 0 : Write / 1 : Read

(4) 03h (Data MSB) — ALS/APS Data Read Mode for Most Significant Bit (MSB)

ST	Slave address								R/W	A	Register address								ST	Slave address								R/W	A	Data (MSB)								SP
	1	0	0	0	1	0	0	0			0 <th>0<td>0</td><td>0</td><td>0</td><td>0</td><td>0</td><td>1</td><td>1</td> <td>1</td><td>0</td><td>0</td><td>0</td><td>1</td><td>0</td><td>0</td><td>0</td> <td>1</td> <td>0</td><td>0</td><td>0</td><td>D11</td><td>D10</td><td>D9</td><td>D8</td> </th>	0 <td>0</td> <td>0</td> <td>0</td> <td>0</td> <td>0</td> <td>1</td> <td>1</td> <td>1</td> <td>0</td> <td>0</td> <td>0</td> <td>1</td> <td>0</td> <td>0</td> <td>0</td> <td>1</td> <td>0</td> <td>0</td> <td>0</td> <td>D11</td> <td>D10</td> <td>D9</td> <td>D8</td>	0	0	0	0	0	1		1	1	0	0	0	1	0	0			0	1	0	0	0	D11	D10	D9	
	1	0	0	0	1	0	0	0	0	0	0	0	0	0	0	1	1	1	0	0	0	1	0	0	0	1												

- ※ D11 is MSB for 12-bit resolution
- ※ R/W Format — 0 : Write / 1 : Read

Surface - Mount Digital Ambient Light Sensor with Proximity Sensor

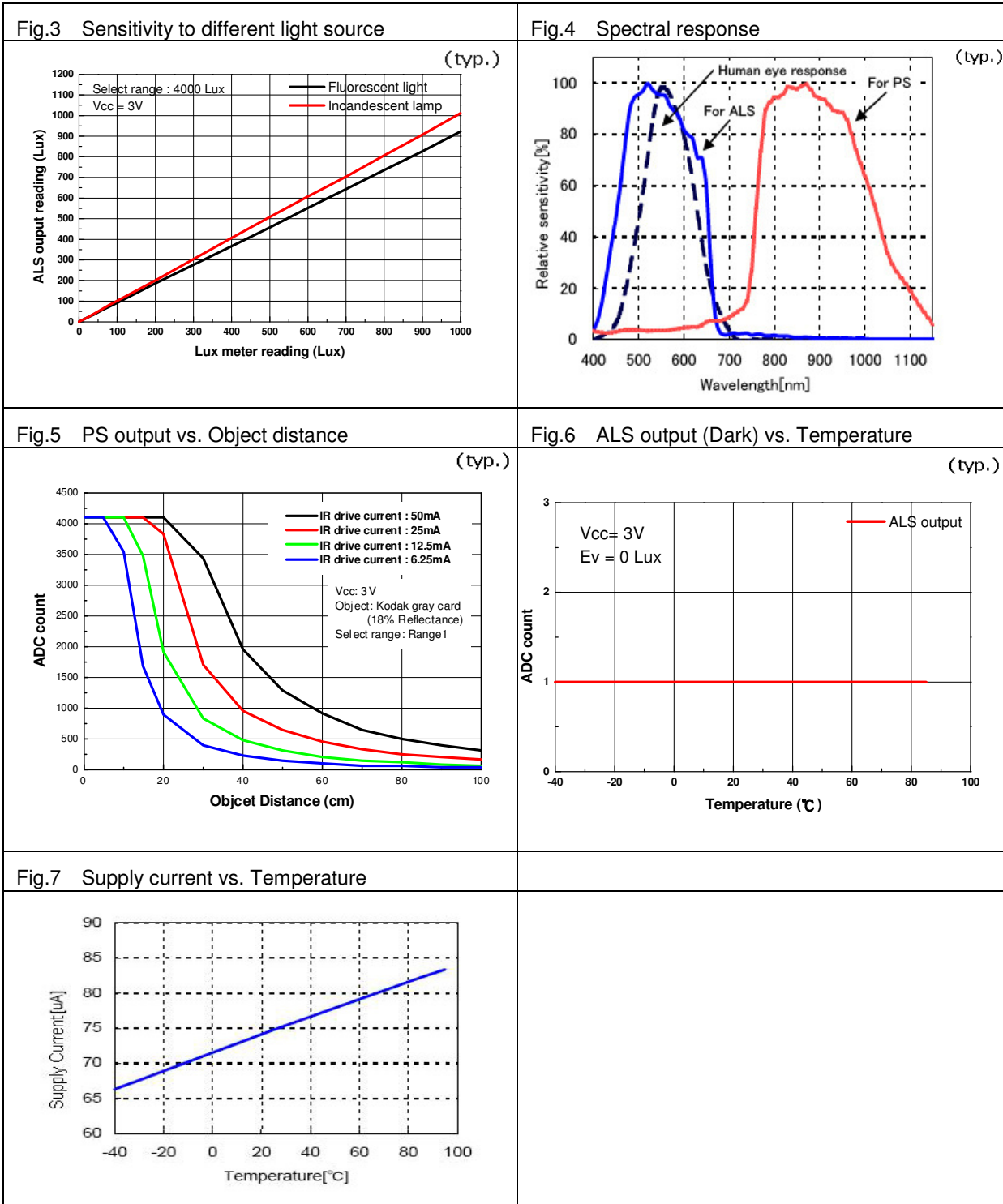

Surface - Mount Digital Ambient Light Sensor with Proximity Sensor

Recommended Solder Profile

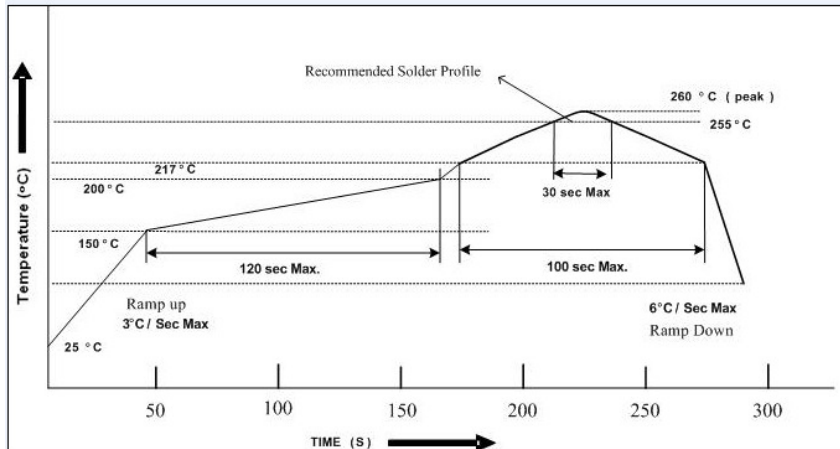

Notice:

1. Reflow soldering should not be done more than two times.
2. When soldering, do not put stress on the devices during heating.
3. After soldering, do not warp the circuit board.

Soldering Iron

Each terminal is to go to the tip of soldering iron temperature less than 350°C for 3 seconds within once in less than the soldering iron capacity 25W. Leave two seconds and more intervals, and do soldering of each terminal. Be careful because the damage of the product is often started at the time of the hand solder.

Repairing

Repair should not be done after the device have been soldered. When repairing is unavoidable, a double-head soldering iron should be used (as below figure). It should be confirmed beforehand whether the characteristics of the device will or will not be damaged by repairing.

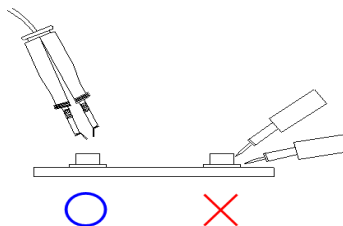



LIGHTING FOREVER

APS-12D-1-02/TR8

Surface - Mount Digital Ambient Light Sensor with Proximity Sensor

Packing Quantity Specification

2000 PCS/ 1 Reel

Label Format

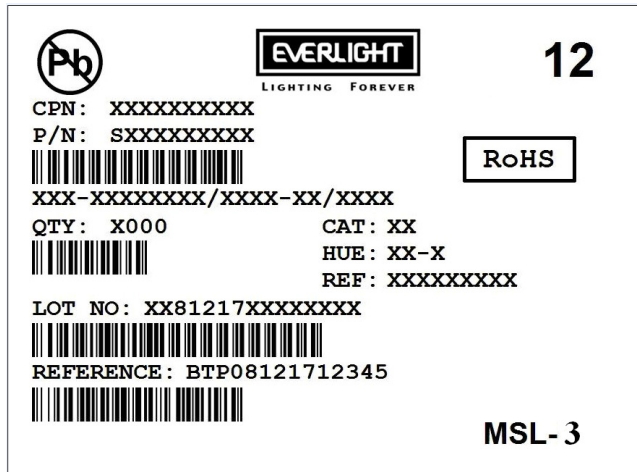

Reel Dimensions

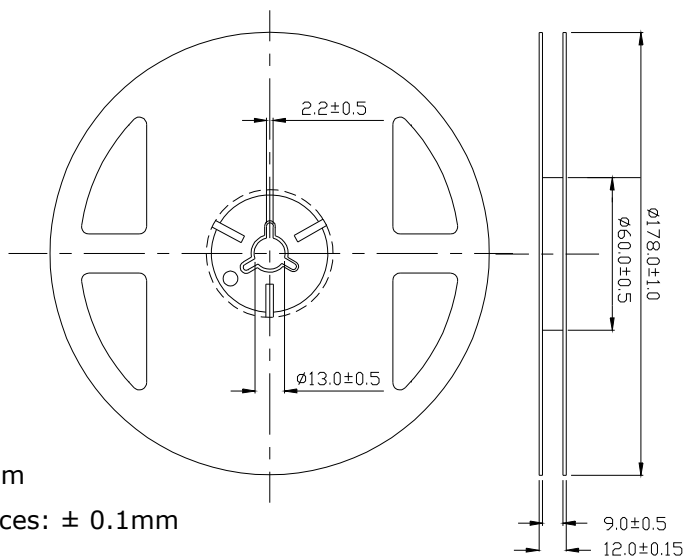

Unit: mm

Tolerances: $\pm 0.1\text{mm}$

Surface - Mount Digital Ambient Light Sensor with Proximity Sensor

Tape Dimensions

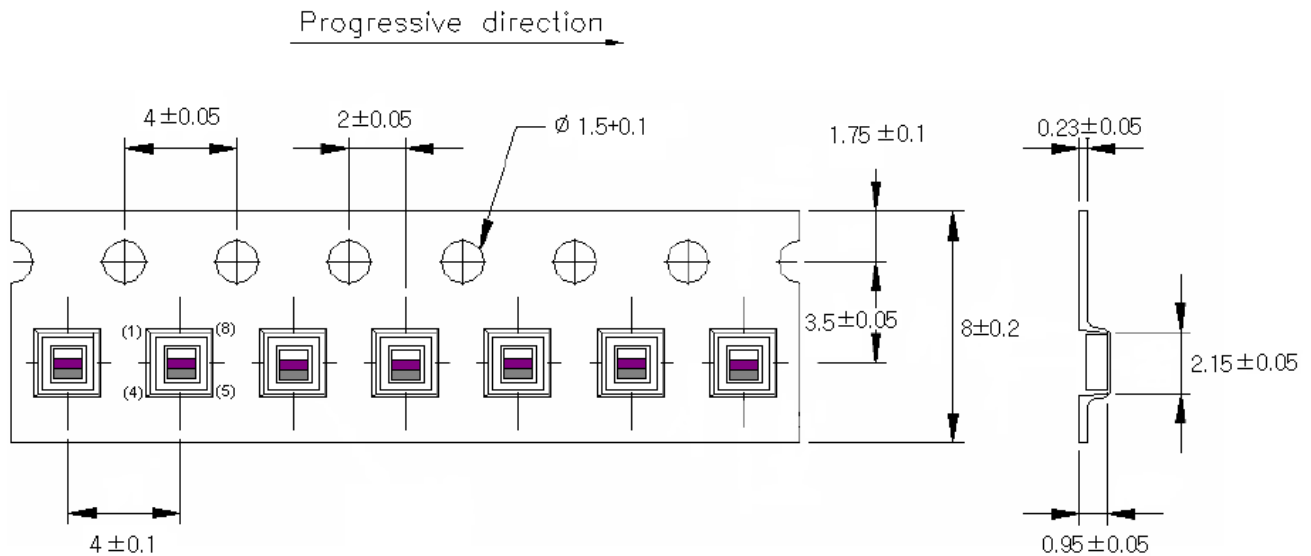

Unit: mm

Tolerances: ± 0.1mm

Note:

1. Above specification may be changed without notice. EVERLIGHT will reserve authority on material change for above specification.
2. When using this product, please observe the absolute maximum ratings and the instructions for using outlined in these specification sheets. EVERLIGHT assumes no responsibility for any damage resulting from use of the product which does not comply with the absolute maximum ratings and the instructions included in these specification sheets.
3. Do not directly touch device.
4. These specification sheets include materials protected under copyright of EVERLIGHT's corporation. Please don't reproduce or cause anyone to reproduce them without EVERLIGHT's consent.