

DATE	REVISIONS	REV
8-5-93	REDRAWN.	A
9-9-94	REVISED INTENSITY SPECIFICATIONS.	B
8-31-95	UPDATED SAFE OPER. SPEC., ADDED TYP TO /E INTEN.	C
3-10-98	E.C.N. #10BRDR. & #10421. & REDRAWN./	D

DRAWING NUMBER SSL-LX100133SRC(/B-/E)	REV D
--	----------

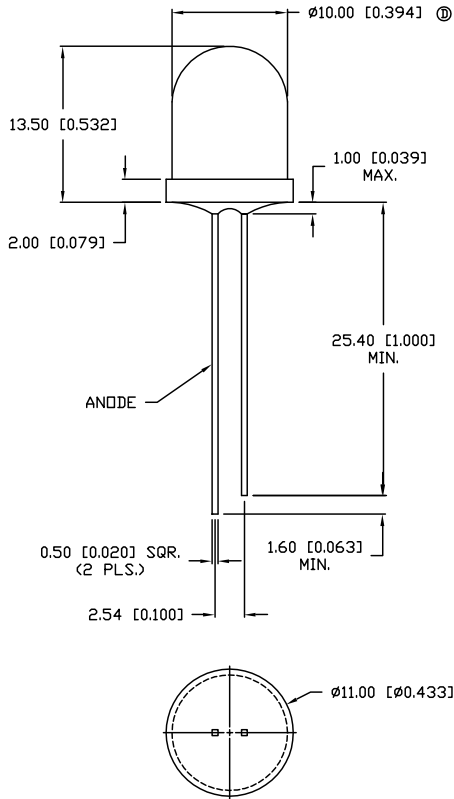

UNLESS OTHERWISE SPECIFIED TOLERANCE IS $\pm 0.25\text{mm}$ ($\pm 0.010''$)

ELECTRO-OPTICAL CHARACTERISTICS $T_A=25^\circ\text{C}$ $I_f=20\text{mA}$

PARAMETER	MIN	TYP	MAX	UNITS	TEST COND
PEAK WAVELENGTH		660 (RED)		nm	
FORWARD VOLTAGE		1.7	2.2	V _f	
REVERSE VOLTAGE	4.0			V _r	$I_r=100\mu\text{A}$
ⓐ AXIAL INTENSITY/B	500	1000		mcd	$I_f=20\text{mA}$
/C	1000	1600		mcd	$I_f=20\text{mA}$
/D	1600	2000		mcd	$I_f=20\text{mA}$
ⓐ /E	2000	2500		mcd	$I_f=20\text{mA}$
VIEWING ANGLE		30		2x theta	
EMITTED COLOR:	RED				
EPOXY LENS FINISH:	WATER CLEAR				

ⓐ LIMITS OF SAFE OPERATION AT 25°C

PARAMETER	MAX	UNITS
PEAK FORWARD CURRENT*	150	mA
STEADY CURRENT	30	mA
POWER DISSIPATION	105	mW
DERATE FROM 25°C	-1.2	mW/°C
OPERATING, STORAGE TEMP.	-40 TO +85	°C
SOLDERING TEMP.	+260	°C
2.0mm FROM BODY		3 SEC. MAX

* $t < 10\mu\text{s}$

RELIABILITY NOTE

OUR MANY YEARS OF EXPERIENCE DATA ACCUMULATION INDICATE THAT SOLDER HEAT IS A MAJOR CAUSE OF EARLY AND FUTURE FAILURE. PLEASE PAY ATTENTION TO YOUR SOLDERING PROCESS.

LUMEX
INCORPORATED

290 E. HELLEN ROAD
PALATINE, ILLINOIS 60067
(847) 359-2790

CONFIDENTIAL INFORMATION
THE INFORMATION CONTAINED IN THIS DOCUMENT IS THE PROPERTY OF LUMEX INCORPORATED. EXCEPT AS SPECIFICALLY AUTHORIZED IN WRITING BY LUMEX INCORPORATED, THE HOLDER OF THIS DOCUMENT SHALL KEEP ALL INFORMATION CONTAINED HEREIN CONFIDENTIAL AND SHALL PROTECT SAME IN WHOLE OR IN PART FROM DISCLOSURE AND DISSEMINATION TO ALL THIRD PARTIES.

DATE: 10-15-91	DWN:	CHK'D:	APPD:
SCALE: N/A			

T-3 1/8mm (T-10) LED, SUPER RED,
WATER CLEAR LENS.

PAGE 1 OF 1	DRAWING NUMBER SSL-LX100133SRC(/B-/E)	REV D
-------------	--	----------