

DATE	REVISIONS	REV
3-2-95	DELETED XRC/4 FROM DWG./	A
5-14-97	E.C.N. #10113./	B
7-9-98	E.C.N. #10BRDR. & REDRAWN./	C

DRAWING NUMBER	REV
SSL-LX100133XRC/1,2,3	C

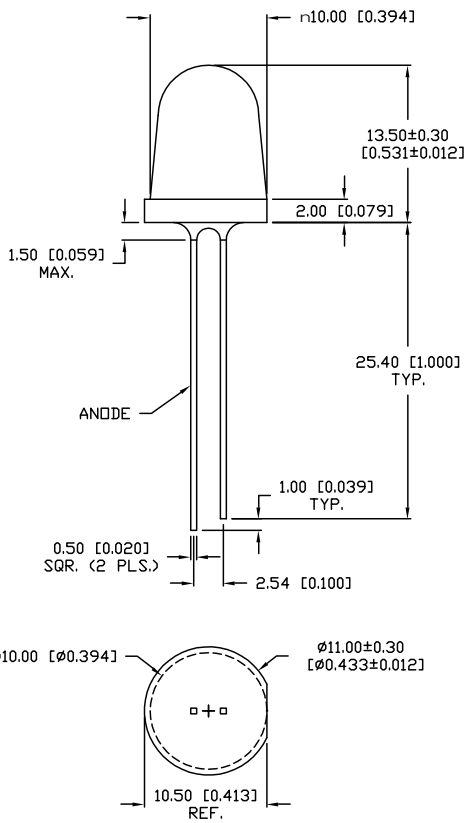

ELECTRO-OPTICAL CHARACTERISTICS  $T_A=25^\circ\text{C}$   $I_f=20\text{mA}$

PARAMETER	MIN	TYP	MAX	UNITS	TEST COND
PEAK WAVELENGTH		660 (RED)		nm	
FORWARD VOLTAGE		1.7	2.4	$V_f$	
REVERSE VOLTAGE	4.0			$V_r$	$I_r = 10 \mu\text{A}$
AXIAL INTENSITY					
SSL-LX100133XRC/1	630	1000		mcd	$I_f = 20\text{mA}$
SSL-LX100133XRC/2	1100	2000		mcd	$I_f = 20\text{mA}$
SSL-LX100133XRC/3	2100	3000		mcd	$I_f = 20\text{mA}$
VIEWING ANGLE		8		$2 \times \theta$	
EMITTED COLOR:	SUPER RED				
EPOXY LENS FINISH:	WATER CLEAR				

LIMITS OF SAFE OPERATION AT  $25^\circ\text{C}$

PARAMETER	MAX	UNITS
PEAK FORWARD CURRENT*	200	mA
STEADY CURRENT	40	mA
POWER DISSIPATION	110	mW
DERATE FROM $25^\circ\text{C}$	-1.2	$\text{mW}/^\circ\text{C}$
OPERATING, STORAGE TEMP.	-40 TO +85	$^\circ\text{C}$
SOLDERING TEMP.	+260	$^\circ\text{C}$
2.0mm FROM BODY		3 SEC. MAX

\*  $t < 10 \mu\text{s}$ ,  $*f = 1\text{KHz}$

RELIABILITY NOTE

OUR MANY YEARS OF EXPERIENCE DATA ACCUMULATION INDICATE THAT SOLDER HEAT IS A MAJOR CAUSE OF EARLY AND FUTURE FAILURE. PLEASE PAY ATTENTION TO YOUR SOLDERING PROCESS.

**LUMEX**  
INCORPORATED

290 E. HELLEN ROAD  
PALATINE, ILLINOIS 60067  
(847) 359-2790

CONFIDENTIAL INFORMATION  
THE INFORMATION CONTAINED IN THIS DOCUMENT IS THE PROPERTY OF LUMEX INCORPORATED. EXCEPT AS SPECIFICALLY AUTHORIZED IN WRITING BY LUMEX INCORPORATED, THE HOLDER OF THIS DOCUMENT SHALL KEEP ALL INFORMATION CONTAINED HEREIN CONFIDENTIAL AND SHALL PROTECT SAME IN WHOLE OR IN PART FROM DISCLOSURE AND DISSEMINATION TO ALL THIRD PARTIES.

DATE: 2-17-94	DWN:	CHK'D:	APPD:
SCALE: N/A			

T-10mm (T-3 1/8) LED, SUPER BRIGHT RED,  
WATER CLEAR LENS, THREE INTENSITY GRADES.

PAGE 1 OF 1	DRAWING NUMBER	REV
	SSL-LX100133XRC/1,2,3	C

UNLESS OTHERWISE SPECIFIED TOLERANCE IS  $\pm 0.25\text{mm}$  ( $\pm 0.010"$ )

MS/BC