

DATE	REVISIONS	REV
3-10-98	E.C.N. #10BRDR. & #10421. & REDRAWN./	A

DRAWING NUMBER	REV
SSL-LX100133SBD/A	A

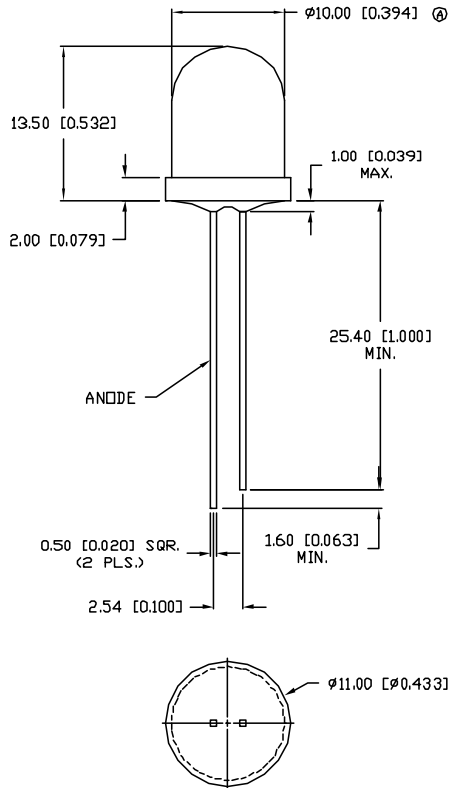

ELECTRO-OPTICAL CHARACTERISTICS $T_A = 25^\circ\text{C}$ $I_f = 20\text{mA}$

PARAMETER	MIN	TYP	MAX	UNITS	TEST COND
PEAK WAVELENGTH		430 (BLUE)		nm	
FORWARD VOLTAGE		4.5	5.5	V_f	
REVERSE VOLTAGE	5.0			V_r	$I_f = 100\mu\text{A}$
AXIAL INTENSITY		25		mcd	$I_f = 20\text{mA}$
VIEWING ANGLE		60		2x theta	
EMITTED COLOR:	BLUE				
EPOXY LENS FINISH:	BLUE DIFFUSED				

LIMITS OF SAFE OPERATION AT 25°C

PARAMETER	MAX	UNITS
PEAK FORWARD CURRENT*	200	mA
STEADY CURRENT	30	mA
POWER DISSIPATION	105	mW
DERATE FROM 25°C	-2.25	mW/ $^\circ\text{C}$
OPERATING, STORAGE TEMP.	-40 TO +85	$^\circ\text{C}$
SOLDERING TEMP.	+260	$^\circ\text{C}$
2.0mm FROM BODY		3 SEC. MAX

* $t < 10\mu\text{s}$

RELIABILITY NOTE

OUR MANY YEARS OF EXPERIENCE DATA ACCUMULATION INDICATE THAT SOLDER HEAT IS A MAJOR CAUSE OF EARLY AND FUTURE FAILURE. PLEASE PAY ATTENTION TO YOUR SOLDERING PROCESS.

LUMEX
INCORPORATED

290 E. HELLEN ROAD
PALATINE, ILLINOIS 60067
(847) 359-2790

CONFIDENTIAL INFORMATION
THE INFORMATION CONTAINED IN THIS DOCUMENT IS THE PROPERTY OF LUMEX INCORPORATED. EXCEPT AS SPECIFICALLY AUTHORIZED IN WRITING BY LUMEX INCORPORATED, THE HOLDER OF THIS DOCUMENT SHALL KEEP ALL INFORMATION CONTAINED HEREIN CONFIDENTIAL AND SHALL PROTECT SAME IN WHOLE OR IN PART FROM DISCLOSURE AND DISSEMINATION TO ALL THIRD PARTIES.

DATE: 10-15-96	DWN:	CHK'D:	APPD:
SCALE: N/A			

T-3 1/8mm (T-10) LED, SUPER BLUE,
BLUE DIFFUSED LENS.

PAGE 1 OF 1	DRAWING NUMBER SSL-LX100133SBD/A	REV A
-------------	-------------------------------------	----------

UNLESS OTHERWISE SPECIFIED TOLERANCE IS $\pm 0.25\text{mm}$ ($\pm 0.010''$)

DU