

UNCONTROLLED DOCUMENT

PART NUMBER
SSL-LX2573HGW-ED

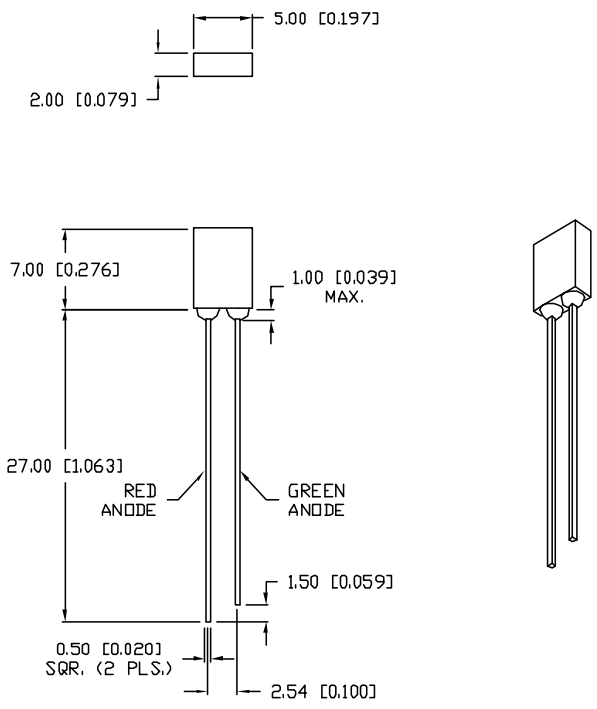

ELECTRO-OPTICAL CHARACTERISTICS $T_A=25^{\circ}\text{C}$ $I_f=20\text{mA}$

PARAMETER	MIN	TYP	MAX	UNITS	TEST COND
PEAK WAVELENGTH		700 (RED)		nm	
		565 (GREEN)		nm	
FORWARD VOLTAGE (R/G)		2.0/2.2	2.5/2.6	V_f	
REVERSE VOLTAGE	5.0			V_r	$I_f=100\mu\text{A}$
AXIAL INTENSITY (R/G)		0.6/7		mcd	$I_f=20\text{mA}$
VIEWING ANGLE		175		2x theta	
EMITTED COLOR:	RED/GREEN				
EPOXY LENS FINISH:	MILKY WHITE				

LIMITS OF SAFE OPERATION AT 25°C

PARAMETER	COLORS	MAX	UNITS
PEAK FORWARD CURRENT*		150	mA
STEADY CURRENT		25	mA
POWER DISSIPATION	(R/G)	120/105	mW
DERATE FROM 25°C		-1.2	mW/ $^{\circ}\text{C}$
OPERATING, STORAGE TEMP.		-40 TO +85	$^{\circ}\text{C}$
SOLDERING TEMP.		+260	$^{\circ}\text{C}$
2.0mm FROM BODY			3 SEC. MAX

* $t < 10\mu\text{s}$

UNCONTROLLED DOCUMENT

*UNLESS OTHERWISE SPECIFIED TOLERANCES PER DECIMAL PRECISION ARE: X=#1 (± 0.039), XX=#0.5 (± 0.020), XXX=#0.25 (± 0.010), XXXX=#0.127 (± 0.005). LEAD SIZE= ± 0.05 (± 0.002), LEAD LENGTH= ± 0.75 (± 0.030). MIN= +DECIMAL PRECISION -0.00 MAX.= +0.00 -DECIMAL PRECISION

REV.	PART NUMBER SSL-LX2573HGW-ED	CONFIDENTIAL INFORMATION THE INFORMATION CONTAINED IN THIS DOCUMENT IS THE PROPERTY OF LUMEX INC. EXCEPT AS SPECIFICALLY AUTHORIZED IN WRITING BY LUMEX INC., THE HOLDER OF THIS DOCUMENT SHALL KEEP ALL INFORMATION CONTAINED HEREIN CONFIDENTIAL AND SHALL PROTECT SAME IN WHOLE OR IN PART FROM DISCLOSURE AND DISSEMINATION TO ALL THIRD PARTIES.	LUMEX INCORPORATED	290 E. HELLEN ROAD PALATINE, ILLINOIS 60067 PHONE: (847) 359-2790 WEB: http://www.lumex.com
2mm x 5mm 700nm RED/565nm GREEN BICOLOR LED, MILKY WHITE EXTRA DIFFUSED LENS.		RELIABILITY NOTE OUR MANY YEARS OF EXPERIENCE DATA ACCUMULATION INDICATE THAT SOLDER HEAT IS A MAJOR CAUSE OF EARLY AND FUTURE FAILURE. PLEASE PAY ATTENTION TO YOUR SOLDERING PROCESS.	DRAWN BY: KS/BC	CHECKED BY:
			APPROVED BY:	DATE: 12.29.00
				PAGE: 1 OF 1
				SCALE: N/A