

**HIGH EFFICIENCY RED HLMP-6600/20  
YELLOW HLMP-6700/20  
HIGH EFFICIENCY GREEN HLMP-6800/20**

**PACKAGE DIMENSIONS**

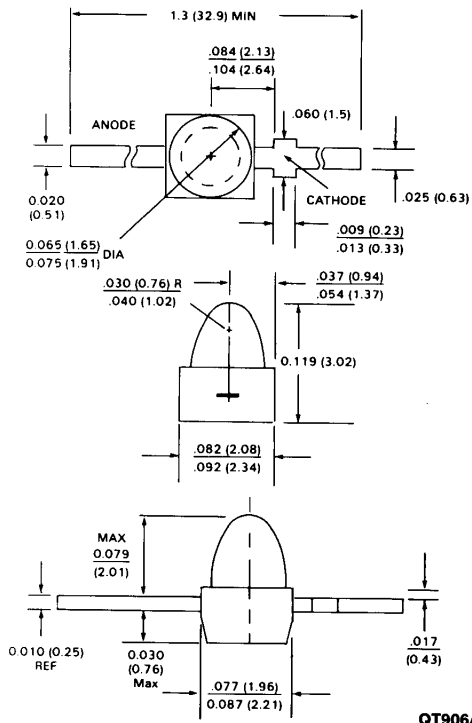

- NOTES:  
1. ALL DIMENSIONS IN INCHES (mm)  
2. TOLERANCE ARE ±.010 INCH UNLESS OTHERWISE SPECIFIED

**DESCRIPTION**

These T-3/4 square based LEDs contain an integral resistor which is in series with the emitter chip. This construction allows for the operation in circuits with 5V supply voltage; without the use of an external resistor. Color tinted, diffused epoxy packages are used for these lamps.

**FEATURES**

- Integral current limiting resistor.
- TTL compatible
- Wide viewing angle
- Solid-state reliability
- SMT lead formings and T&R available

**ABSOLUTE MAXIMUM RATING** (T<sub>A</sub> = 25°C unless otherwise specified)

PARAMETER	RED	YELLOW	GREEN	UNITS
Power dissipation	135	85	135	mW
DC forward voltage	6	6	6	V
Lead soldering time at	3	3	3	Sec
Surface mount reflow soldering				
Convective IR at 235°C				90 Seconds
Vapour phase at 213°C				3 Minutes
Operating temperature range				-40°C to 85°C
Storage temperature range				-55°C to 100°C

**TYPICAL THERMAL CHARACTERISTICS**

Thermal resistance $\theta_{JA}$	120°C/W
----------------------------------	---------

<b>ELECTRO-OPTICAL CHARACTERISTICS</b> ( $T_A = 25^\circ\text{C}$ Unless Otherwise Specified)					
PARAMETER	MIN.	TYP.	MAX.	UNITS	TEST CONDITIONS
Forward current - $I_f$					
HLMP-6600/6700/6800		9.6	13.0	mA	$V_f = 5\text{ V}$
HLMP-6620/6720/6820		3.5	5.0	mA	$V_f = 5\text{ V}$
Reverse voltage - $V_R$	5	30		V	$I_R = 100\mu\text{A}$
Viewing angle - $2\theta$		90		Degree	
Luminous intensity - $I_v$					
HLMP-6600/6700/6800	1.3	5.0		mcd	$V_f = 5\text{ V}$
HLMP-6620/6720/6820	0.8	2.0		mcd	$V_f = 5\text{ V}$
Peak wavelength					
HLMP-6600/20		635		nm	
HLMP-6700/20		583		nm	
HLMP-6800/20		565		nm	
Dominant wavelength					
HLMP-6600/20		626		nm	
HLMP-6700/20		585		nm	
HLMP-6800/20		569		nm	
Spectral line half-width					
HLMP-6600/20		40		nm	
HLMP-6700/20		36		nm	
HLMP-6800/20		28		nm	
Capacitance - C					
HLMP-6600/20		11		pF	$V_f = , F = 1\text{ MHz}$
HLMP-6700/20		15		pF	$V_f = , F = 1\text{ MHz}$
HLMP-6800/20		18		pF	$V_f = , F = 1\text{ MHz}$

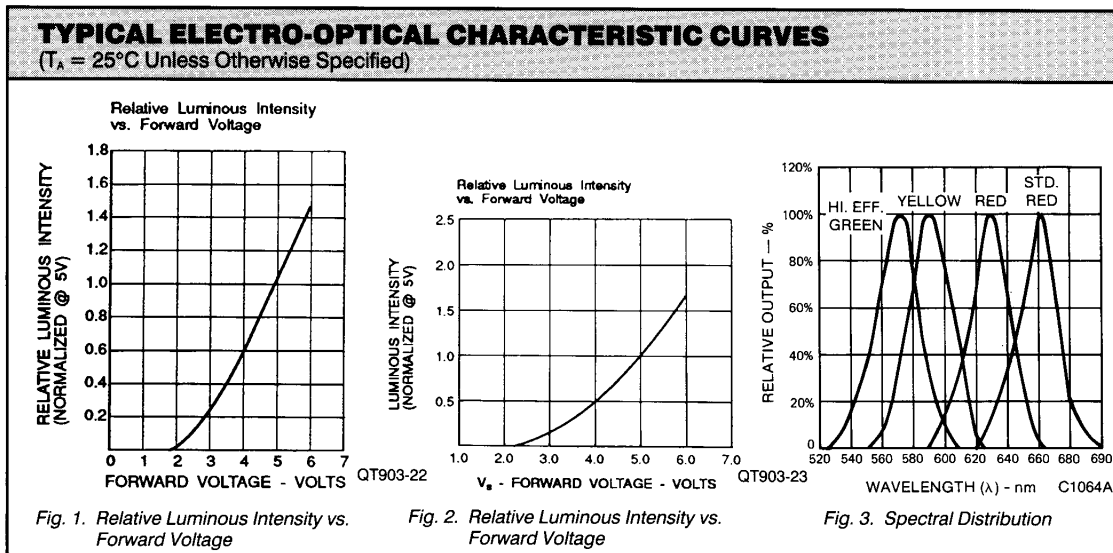

**DISCLAIMER**

FAIRCHILD SEMICONDUCTOR RESERVES THE RIGHT TO MAKE CHANGES WITHOUT FURTHER NOTICE TO ANY PRODUCTS HEREIN TO IMPROVE RELIABILITY, FUNCTION OR DESIGN. FAIRCHILD DOES NOT ASSUME ANY LIABILITY ARISING OUT OF THE APPLICATION OR USE OF ANY PRODUCT OR CIRCUIT DESCRIBED HEREIN; NEITHER DOES IT CONVEY ANY LICENSE UNDER ITS PATENT RIGHTS, NOR THE RIGHTS OF OTHERS.

**LIFE SUPPORT POLICY**

FAIRCHILD'S PRODUCTS ARE NOT AUTHORIZED FOR USE AS CRITICAL COMPONENTS IN LIFE SUPPORT DEVICES OR SYSTEMS WITHOUT THE EXPRESS WRITTEN APPROVAL OF THE PRESIDENT OF FAIRCHILD SEMICONDUCTOR CORPORATION. As used herein:

1. Life support devices or systems are devices or systems which, (a) are intended for surgical implant into the body, or (b) support or sustain life, and (c) whose failure to perform when properly used in accordance with instructions for use provided in the labeling, can be reasonably expected to result in a significant injury of the user.
2. A critical component in any component of a life support device or system whose failure to perform can be reasonably expected to cause the failure of the life support device or system, or to affect its safety or effectiveness.