

REV.	DESCRIPTION	DATE	APPROVED
A	Engineering Update w/o Changes	03/10/04	M. C.
B	Polarity Update	09/11/06	M. C.

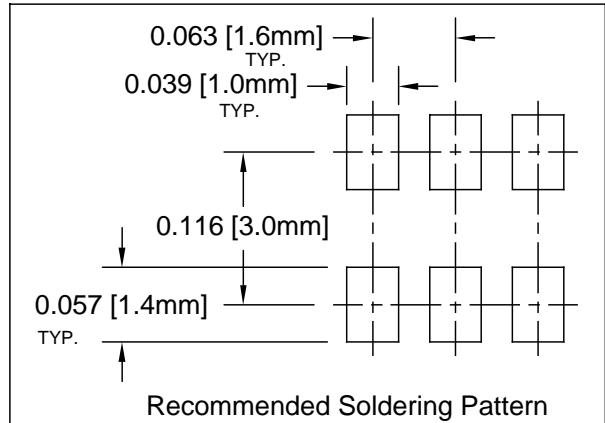
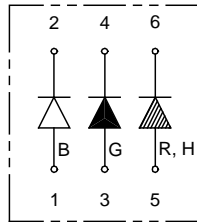
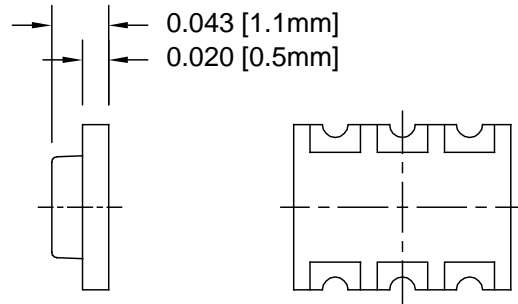
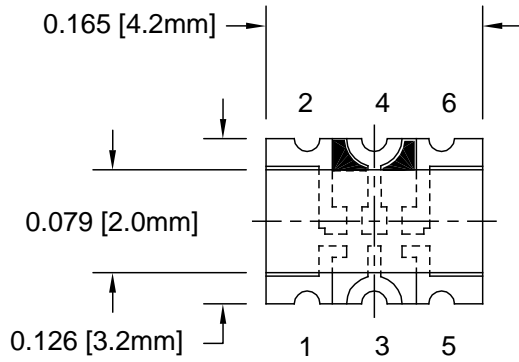

### ABSOLUTE MAXIMUM RATINGS (Ta=25 °C)

REVERSE VOLTAGE	_____	5V
REVERSE CURRENT	_____	100uA
OPERATING TEMPERATURE RANGE	_____	-25° C - 85° C
STORAGE TEMPERATURE	_____	-30° C - 100° C
LEAD SOLDERING TEMPERATURE(1/16" FROM BODY)	_____	260° C FOR 5 SECONDS

STANDARD TOLERANCE (UNLESS OTHERWISE SPECIFIED)		BIVAR®	
DECIMALS	ANGULAR	4 THOMAS, IRVINE, CA. 92618 TEL: (949) 951-8808 FAX: (949) 951-3974	
.X ± .1	X° ± 1°	TITLE:	SURFACE MOUNT LED, TRI-COLOR
.XX ± .02		PART NO:	SM1317XXXX
.XXX ± .010		DESIGNED:	David Green
		DATE:	03/10/04
		CHECKED:	T. Yin
		DATE:	03/10/04
		CAGE CODE:	32559
		SHEET #	1 OF 3
		CAD GENERATED DOCUMENT. DO NOT MEASURE DRAWING.	

REV.	DESCRIPTION	DATE	APPROVED
	SEE SHEET#1.		

LED Part No.	Chip			Lens Appearance	Absolute Max. Ratings				Electro-Optical Data @ 20ma			Viewing Angle 2 $\theta$ 1/2 (Deg)
	Material	Peak Wave Length $\lambda_p$ (nm)	Emitted Color		$\Delta\lambda$ (nm)	Pd (mW)	If (mA)	Peak If(mA)	Vf (V)		Iv (mcd)	
									TYP	MAX	TYP	
SM1317RGB	GaAlAs	656	Red	WHITE DIFFUSED	24	100	30	150	1.8	2.3	20	120
	GaP	566	Green		31	100	30	150	2.2	2.6	17	
	GaN/SiC	430	Blue		60	100	30	150	4.0	4.5	8	
SM1317HGB	AlGaInP	620	Orange	WHITE DIFFUSED	17	100	30	150	2.0	2.5	75	120
	InGaN/SiC	505	Green		37	100	30	150	3.3	4.0	120	
	GaN	465	Blue		33	100	30	150	3.3	3.8	38	
SM1317SRGB	GaAlAs	654	S. Red	WHITE DIFFUSED	23	100	30	150	2.0	2.5	45	120
	InGaN/SiC	525	S. Green		40	100	30	150	3.2	3.6	120	
	GaN	460	S. Blue		36	100	30	150	3.4	4.0	52	

STANDARD TOLERANCE (UNLESS OTHERWISE SPECIFIED) $\pm 10\%$ ALL VALUES		ANGULAR X° $\pm 5^\circ$		 <b>BIVAR</b> <sup>®</sup> 4 THOMAS, IRVINE, CA. 92618 TEL: (949) 951-8808 FAX: (949) 951-3974	
DESIGNED: <b>David Green</b>		DATE: <b>03/10/04</b>		TITLE: SURFACE MOUNT LED, TRI-COLOR PART NO: <b>SM1317XXXX</b> REVISION: <b>B</b>	
CHECKED: <b>T. Yin</b>		DATE: <b>03/10/04</b>		CAGE CODE : <b>32559</b> SHEET # <b>2 OF 3</b> CAD GENERATED DOCUMENT. DO NOT MEASURE DRAWING.	

REV.	DESCRIPTION	DATE	APPROVED
	SEE SHEET#1.		

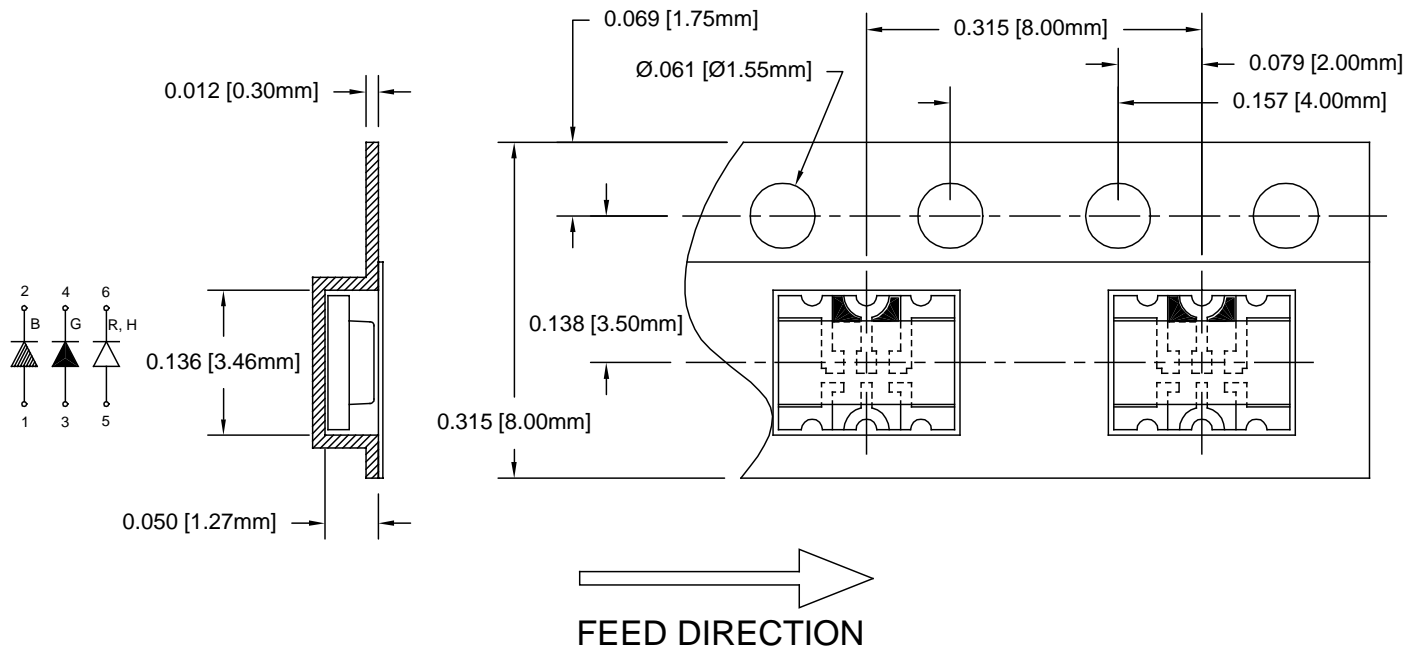

2. UNLESS OTHERWISE SPECIFIED,  
PACKAGING TO COMPLY WITH EIA-481-B  
1. 2000 pcs PER REEL

STANDARD TOLERANCE (UNLESS OTHERWISE SPECIFIED)		BIVAR®	
DECIMALS	ANGULAR	4 THOMAS, IRVINE, CA. 92618 TEL: (949) 951-8808 FAX: (949) 951-3974	
.X ± .1	X° ± 1°	TITLE: SURFACE MOUNT LED, TRI-COLOR	
.XX ± .02		DESIGNED: David Green	DATE: 03/10/04
.XXX ± .010		CHECKED: T. Yin	DATE: 03/10/04
		PART NO: SM1317XXXX	REVISION: B
		CAGE CODE: 32559	SHEET # 3 OF 3
CAD GENERATED DOCUMENT. DO NOT MEASURE DRAWING.			