

Advanced Power TOPLED Plus – Details on Properties, Handling and Mounting

Application Note

Abstract

This application note provides information about the "Advanced Power TOPLED Plus" (APT Plus) LED from OSRAM Opto Semiconductors.

A basic overview of the construction, handling and optical characteristics of the LED is presented. In addition, processing information and a sample application are provided.

Advanced Power TOPLED Plus

The Advanced Power TOPLED Plus ("APT Plus") is the further development of the standard Advanced Power TOPLED. With its robust housing, it features optimized (~15% brighter) light coupling, wide radiation characteristics and efficient heat dissipation.

With its high light output up to 90 lm/W and low power consumption, it can be used convincingly in all applications in which intense light is required, but little room or installation space is available.

The APT Plus is therefore predestined for homogeneous area lighting or the pronounced emphasis of edges and lines such as those used in architectural and sales illumination.

Its characteristics make it suitable for use in the following application areas of illumination technology:

Backlighting

- Direct-view LCD backlighting
- Light guide LCD backlighting



Industry and signs

- Large-pixel video walls
- Variable-message signs (VMS)
- Fridge lighting
- Vending machine

Solid state lighting

- Indoor and outdoor lighting
- Freezer case lighting
- Architectural lighting
- Commercial and residential illumination
- Area backlighting and light titles
- Marker lights (e.g. steps, exit routes, etc.)
- Channel letters

Features and construction

As with the majority of mid-power SMT LEDs available, the construction of the APT Plus consists of a preprocessed plastic housing (pre-mold) with integrated connecting contacts.

In addition to mounting and electrical connection of the LED to the circuit board, the gold-plated (NiAu) leadframe also serves to dissipate the heat that arises during operation.

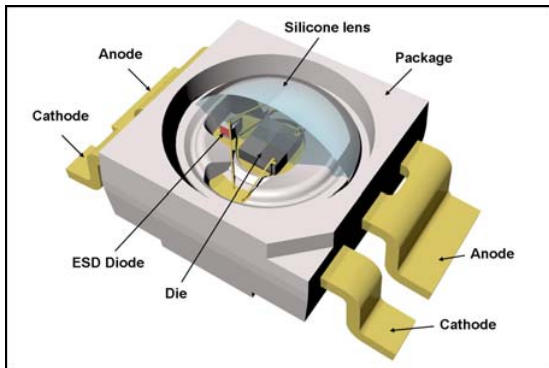

Figure 2: Internal construction of the Advanced Power TOPLED Plus

Within the housing, the semiconductor chip and the ESD diode are mounted to the anode side of the leadframe and make contact with the cathode side by means of wire bonding.

For the Advanced Power TOPLED Plus, this results in a typical thermal resistance of 40 K/W and ESD protection up to 2 KV according to JESD22A-114D.

As the centerpiece and actual lightsource of the Advanced Power TOPLED Plus, highly efficient semiconductor chips of the latest thin film technology are used.

The APT Plus is available in red, green and blue as well as the white colors of Ultra White and Warm White (Table 1).

LED Type	Color	Wavelength
LR G5AP	Red	623 nm
LT G5AP	True Green	527 nm
LD G5AP	Deep Blue	457 nm
LUW G5GP	Ultra White	5700K - 6500K*
LCW G5GP	Warm White	2700K - 4500K*

*Color temperature

Table 1: The different variants of the Advanced Power TOPLED Plus

In contrast to the standard Advanced Power TOPLED, the silicone encapsulant of the APT Plus is formed into a lens.

The silicone casted lens serves as a cost-efficient device to optimize efficiency, by allowing most of the generated light to directly leave the LED.

As opposed to a more expensive precision molded lens, the casted lens is not intended to serve as a high precision optical element, due to its inherently larger lens shape variations.

In many applications such as backlighting and general illumination where narrow spots are not required, the casted lens shape tolerances will not have any noticeable influence.

Figure 3 shows the radiation characteristics of the APT Plus.

Through the combination of a lower installation height (only 2.25 mm), adapted radiation characteristics and exceptional light output, the APT Plus permits the implementation of flat designs based on direct-view backlighting.

When used for display backlighting, the APT Plus, structured as RGB backlighting, achieves a color gamut of more than 120% of the NTSC Standard, allowing truly brilliant images to be displayed.

With these excellent characteristics, the APT Plus offers an optimal ratio of brightness in the application to system density with a minimal number of LEDs, for flat backlighting as well as illumination solutions.

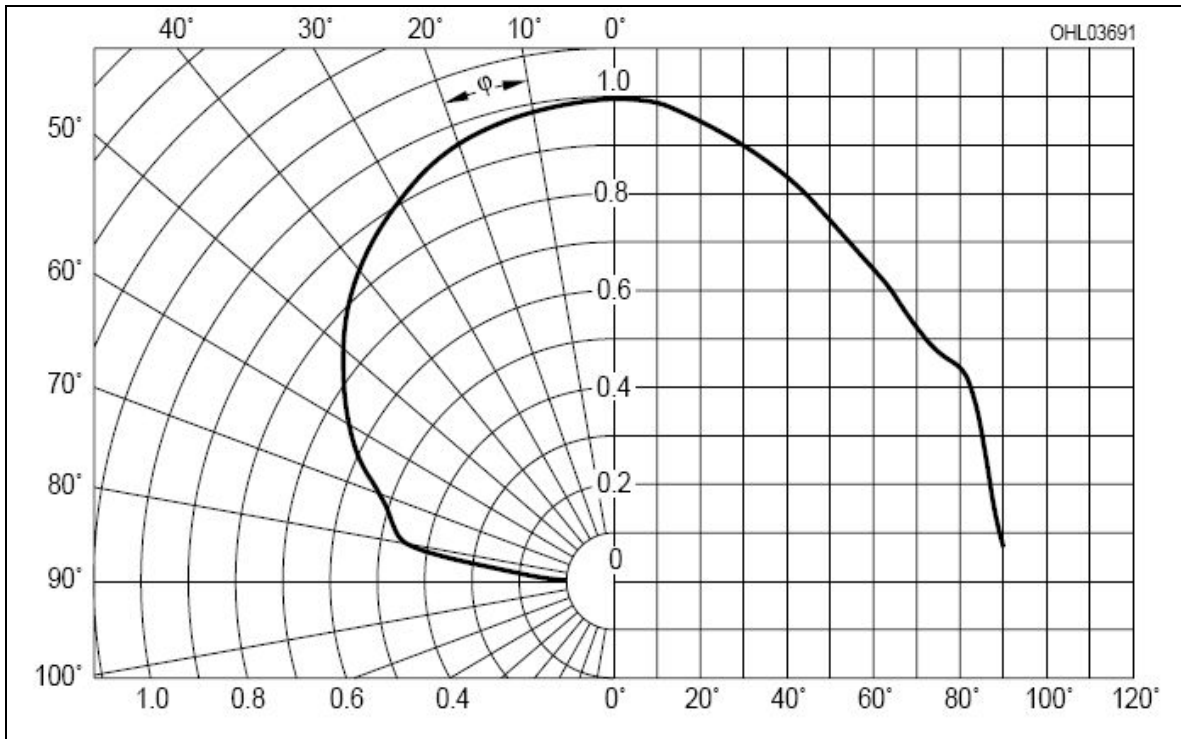

Figure 3: Radiation characteristics of the Advanced Power TOPLED Plus

Beyond that, the Advanced Power TOPLED Plus fulfills the current RoHS guidelines (European Union & China), and therefore contains no lead or other hazardous substances.

Handling

Accessory to general guidelines for the handling of LEDs, additional care should be taken that mechanical stresses (e.g. sheering forces) to the elastic silicone encapsulation must be reduced or eliminated to the greatest extent possible (see also application note "Handling of Silicone Resin LEDs").

In general, all types of sharp objects (e.g. forceps, fingernails, etc.) should be avoided in order to prevent stress to or penetration of the encapsulation, since this can lead to spontaneous failure of the LED (damage to the wire).

For manual assembly and placement – in the production of prototypes, for example – the use of so-called vacuum tweezers is recommended.

By means of individually exchangeable soft rubber suction tips, the effective mechanical stress on the LED is minimized (Figure 4).

The vacuum stylus functions such that by pressing on the button, a vacuum is created, similar to vacuum tweezers, with which the component (e.g. the LED) can be lifted.



Figure 4: Examples of vacuum styluses

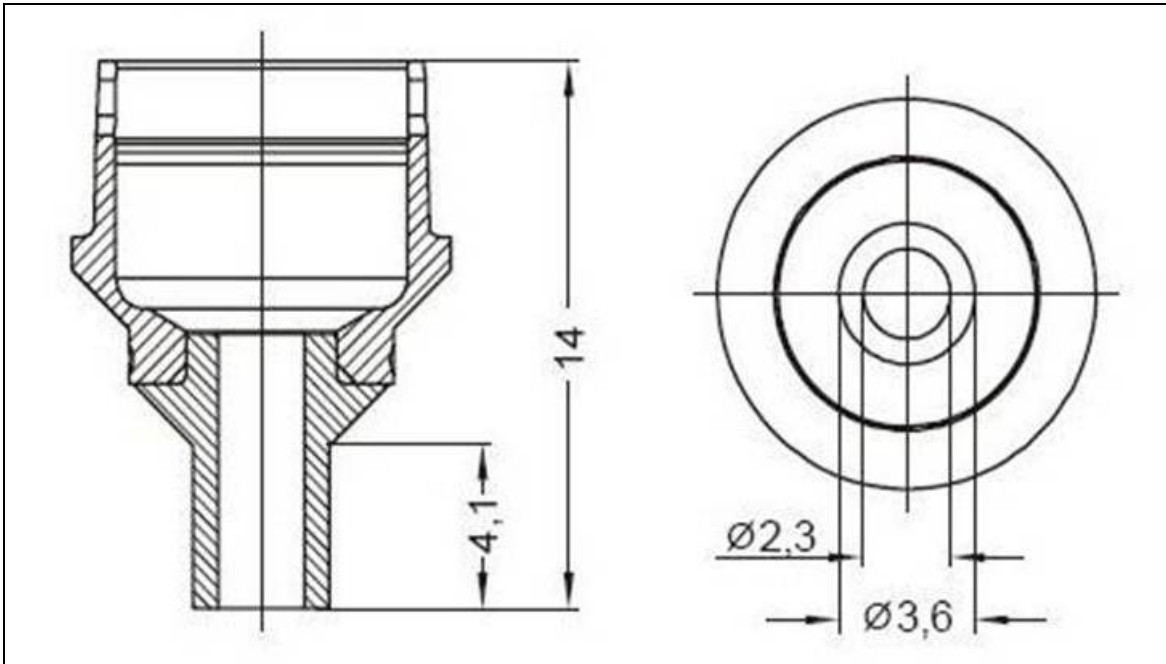

Figure 5: Recommended design of the Pick & Place Tool for the APT Plus

By releasing the pressure on the button, the vacuum is removed and the component can be placed at the desired position.

When processing by means of automated placement machines, care should be taken that an appropriate pick and place tool is used and that the process parameters conform to the package characteristics.

Figure 5 shows the recommended design for the pick and place tool for damage-free processing of the Advanced Power TOPLED Plus.

Cleaning of the APT Plus should only be performed with isopropyl alcohol (see also application note "Cleaning of LEDs"). Other cleansers or ultrasonic cleaning can lead to failure of the LED.

Processing

The Advanced Power TOPLED Plus is generally supplied in tape and reel format. Each reel only contains a single brightness group and a single wavelength or color group. That is, from the brightness groups within the family, one tape contains only one of the groups.

The APT Plus is generally compatible with existing industrial SMT processing methods, so that all customary populating techniques can be used for assembly.

For mounting the component, a standard reflow soldering process is recommended, in which a typical lead-free SnAgCu metal alloy solder is used.

Figure 6 shows the solder requirements and temperature curve for lead-free soldering of the APT Plus.

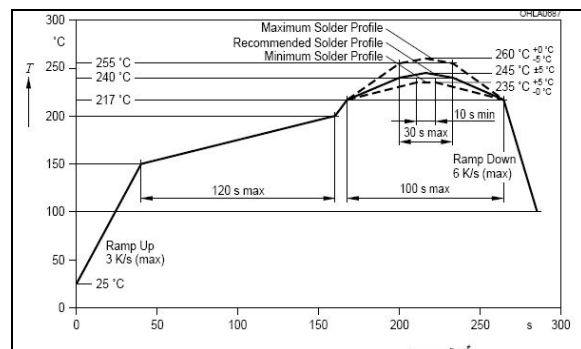

Figure 6: IR reflow soldering profile for lead-free soldering of the APT Plus

The LED should be prepared according to JEDEC Level 4.

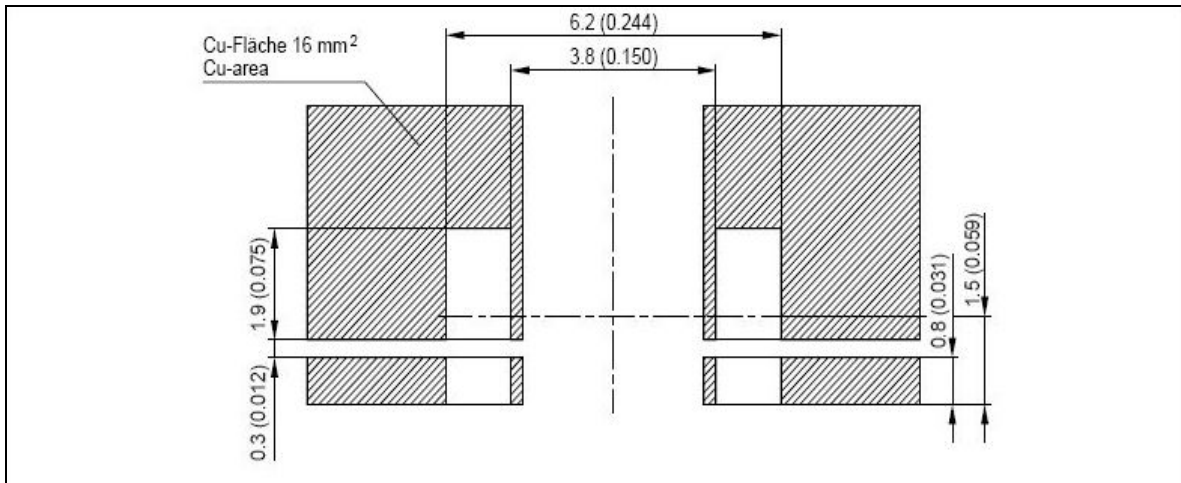





Figure 7: Recommended solder pad for the Advanced Power TOPLED Plus

For optimal mounting of the Advanced Power TOPLED Plus on the circuit board and in order to guarantee the performance of the LED, it is advantageous to use the recommended solder pad (Figure 7) in most cases.

Depending on the total input power, the APT Plus can be mounted on various PCB materials such as

-  FR4
-  FlexPCB / Flex on aluminum/copper
-  Metal core PCB (IMS-PCB)

Due to the high efficiency of the LED, the use of an additional heat sink can be avoided in many applications, since the heat is dissipated via the contacts and the circuit board.

Application example

The possible use of the APT Plus in different lighting environments will be demonstrated by means of the following example.

Figure 8 shows an LED light, 350 mm in length, in which 30 APT Plus LEDs (LCW G5GP with 18 lm @100 mA) with a color temperature of 3000 K are used as the lightsource.

With a total power of around 12 Watts including control circuitry, the LED module provides a luminous flux of 540 lm for the illumination. The LED module itself is mounted to an aluminum rail, which also serves to dissipate heat.

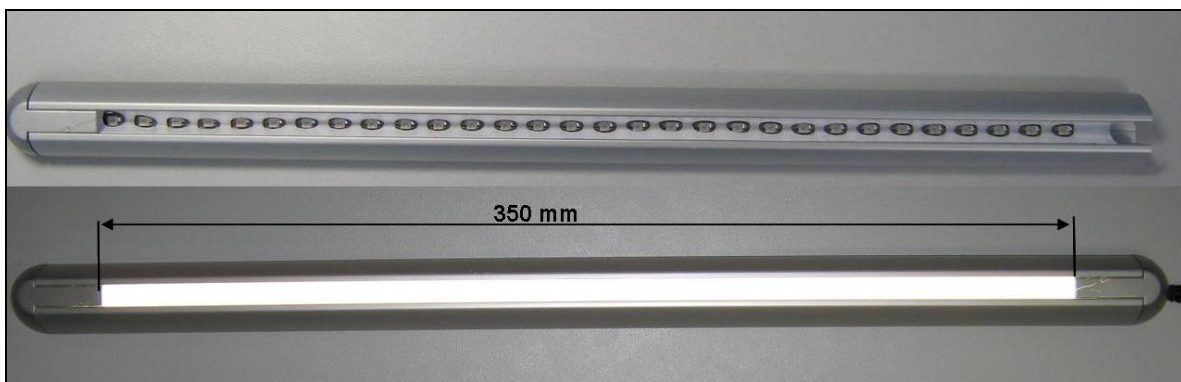

Figure 8: LED Lamp with APT Plus

If one compares the data for the LED module with a correspondingly sized T2 lamp (e.g. FM 13 W/730 lm, 71.5 lm/W), at first glance, it appears that the T2 lamp has better values than the LED module, particularly with regard to luminous flux and efficiency.

In practice, however, it can be seen that the LED variant, constructed as a narrow light, possesses considerably higher system efficiency than the light with the CCFL lamp (Figure 9).

With the CCFL lamp, only a small portion of the total available light can be used, due to self-shadowing by the CCFL and design-related issues. For a CCFL with an optical efficiency value of 72 m/W, this means that a real efficiency value of only 43 lm/W can be used in the system.

With the LED light nearly 100% of the luminous flux can be used, due to the unidirectional radiation of light, in which the system efficiency is equal to the LED

efficiency. At higher color temperatures, the superiority of the LED with respect to the CCFL is even more apparent (e.g. APT Plus LUW G5GP 85 lm/W @100 mA and 6500 K).

In addition, the LED light has further decisive advantages in comparison to the CCFL variant for its use in illumination. As a rule, warm white LEDs have a higher color reproduction index (Ra = 80) than CCFL lamps (Ra = 70-78), whereby the different colors are better reproduced or more easily distinguished.

In addition to this visual advantage, LEDs also have other advantages in comparison to CCFL lamps, due to their packaging technology (e.g. vibration and shock resistance, scalability, temperature range of -40°C to +85°C, etc.) and/or the physical characteristics of the semiconductor technology (e.g. instant light on and off (< 100 ns), unlimited dimming, etc.).

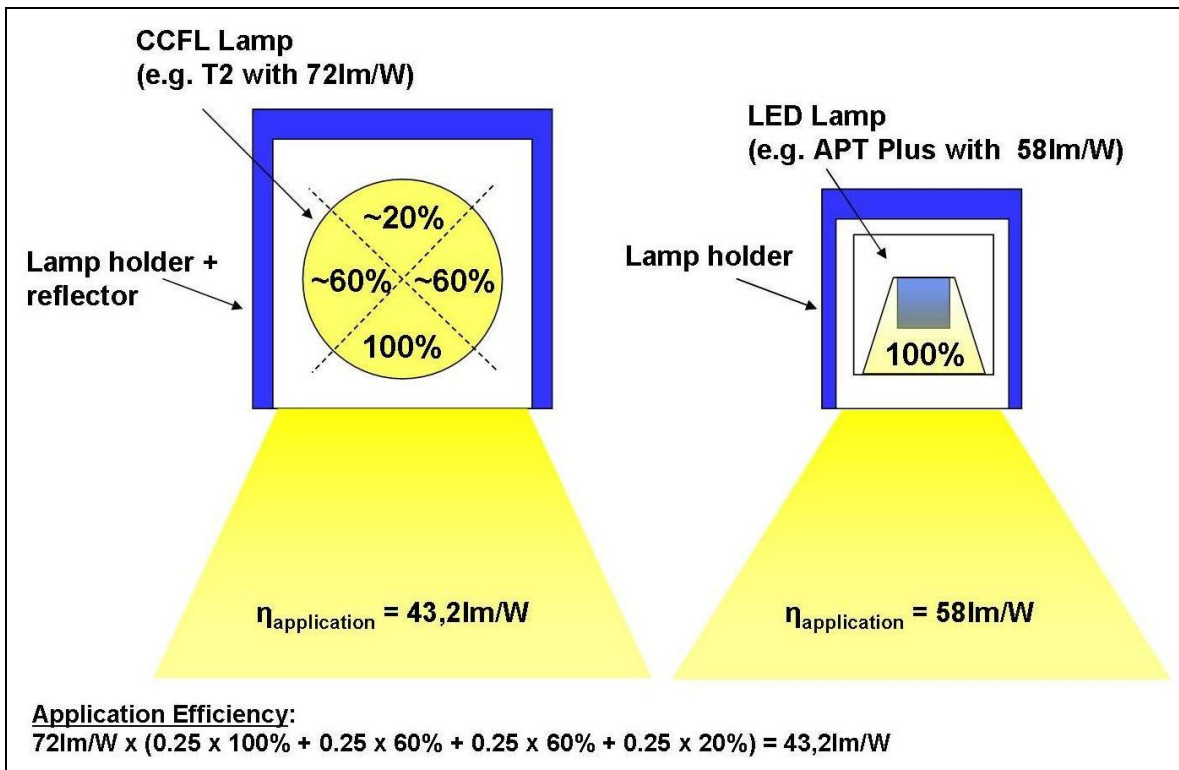

Figure 8: Comparison of the system efficiency of CCFL lamp vs. LED lamp

Summary

Specially designed and engineered to meet today's backlighting and illumination needs, the Advanced Power TOPLED Plus packs outstanding brightness into a mid-power package making it the perfect light source for thin applications that require bright, homogeneous lighting.

Therefore the LED fitted with a newly developed lens is ideal for absolutely uniform backlighting of liquid crystal displays (LCDs) as well as diffused surfaces.

Its advantages and strengths are also convincing for illumination of facades or building contours as well as in the area of sales such as in refrigerated display counters.

In general, the APT Plus can be used without expensive thermal management in spite of a specified input power of up to 0.5 Watts, since the heat which arises can be efficiently dissipated by means of the contacts and the circuit board.

With its optimized light coupling, excellent thermal design and improved lifetime, the Advanced Power TOPLED Plus LED is exceptionally well equipped and is suitable for use in the multifaceted domain of general illumination.

It permits the creation of lighting solutions which essentially know no limitations with respect to design and flexibility, and until now, could not be realized with conventional luminants.

Appendix



Don't forget: LED Light for you is your place to be whenever you are looking for information or worldwide partners for your LED Lighting project.

www.ledlightforyou.com

Author: Andreas Stich

About Osram Opto Semiconductors

Osram Opto Semiconductors GmbH, Regensburg, is a wholly owned subsidiary of Osram GmbH, one of the world's three largest lamp manufacturers, and offers its customers a range of solutions based on semiconductor technology for lighting, sensor and visualisation applications. The company operates facilities in Regensburg (Germany), San José (USA) and Penang (Malaysia). Further information is available at www.osram-os.com.

All information contained in this document has been checked with the greatest care. OSRAM Opto Semiconductors GmbH can however, not be made liable for any damage that occurs in connection with the use of these contents.