



## Technical Data Sheet

# Luminosity White Color LED

**47-23UWD/TR8**

### Features

- Super luminosity white LED.
- Built in 3 LED chips.
- Wide viewing angle.
- Soldering methods: Reflow soldering.
- High performance.
- Package in 12mm tape on 7" diameter reel.
- Pb-free.
- RoHS refer to SMD B TYPE SGS report
- The product itself will remain within RoHS compliant version.

### Descriptions

- The 47-23 SMD LED is much smaller than lead frame type components, thus enable smaller board size, higher packing density, reduced storage space and finally smaller equipment to be obtained.
- Besides, lightweight makes them ideal for miniature applications. etc.

### Applications

- Amusement equipment.
- Information boards.
- Flashlight for digital camera of cellular phone.
- Lighting for small size device.

### Device Selection Guide

Chip		Lens Color
Material	Emitted Color	
InGaN	White	Yellow diffused

**Package Outline Dimensions**

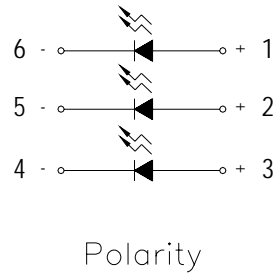
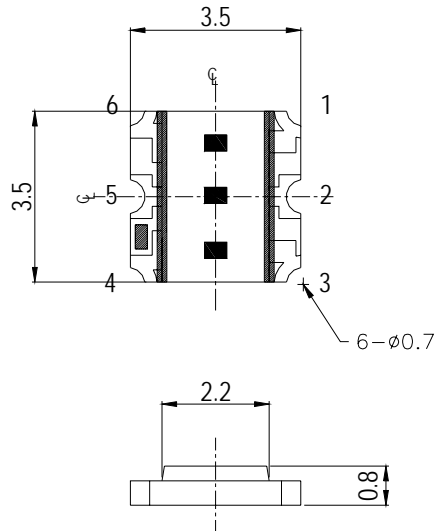

For Reflow Soldering(Propose)

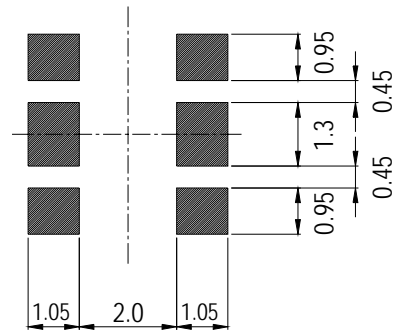
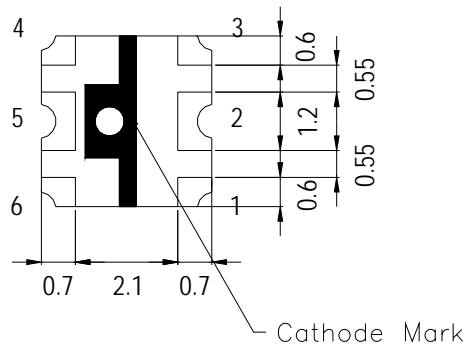

**Note:** The tolerance unless mentioned is  $\pm 0.1\text{mm}$ , unit is mm

**Absolute Maximum Ratings (Ta=25°C)**

Parameter	Symbol	Rating	Unit
Reverse Voltage	V <sub>R</sub>	5	V
Operating Temperature	Topr	-40 ~ +85	°C
Storage Temperature	Tstg	-40 ~ +90	°C
Soldering Temperature	Tsol	260 (for 5 second)	°C
Power Dissipation	Pd	74	mW
Forward Current	I <sub>F</sub>	25	mA
Peak Forward Current (Duty 1/10 @ 1KHz)	I <sub>FP</sub>	100	mA

\*. The value is based on the 1-die performance.

**Electro-Optical Characteristics (Ta=25°C)**

Parameter	Symbol	Min.	Typ.	Max.	Unit	Condition
Luminous Intensity*1	I <sub>v</sub>	1500	2000	-----	mcd	I <sub>F</sub> =20mA*2
Viewing Angle*1	2θ <sub>1/2</sub>	-----	130	-----	deg	
Forward Voltage*2	V <sub>F</sub>	2.7	-----	3.7	V	
Reverse Current*2	I <sub>R</sub>	-----	-----	50	μA	V <sub>R</sub> =5V*2

\*1 When three LED dies are operated simultaneously.

\*2 For each die.

Note:

1. The products are sensitive to static electricity and care must be fully taken when handling products.
2. We only guarantee the ESD <1000V after customer to process.

**Color Ranks**

	Rank A0			
x	0.280	0.264	0.283	0.296
y	0.248	0.267	0.305	0.276

	Rank B3			
x	0.287	0.283	0.304	0.307
y	0.295	0.305	0.330	0.315

	Rank B4			
x	0.307	0.304	0.330	0.330
y	0.315	0.330	0.360	0.339

	Rank B5			
x	0.296	0.287	0.307	0.311
y	0.276	0.295	0.315	0.294

	Rank B6			
x	0.311	0.307	0.330	0.330
y	0.294	0.315	0.339	0.318

	Rank C0			
x	0.330	0.330	0.361	0.356
y	0.318	0.360	0.385	0.351

\*The C.I.E. 1931 chromaticity diagram ( Tolerance  $\pm 0.01$ ).

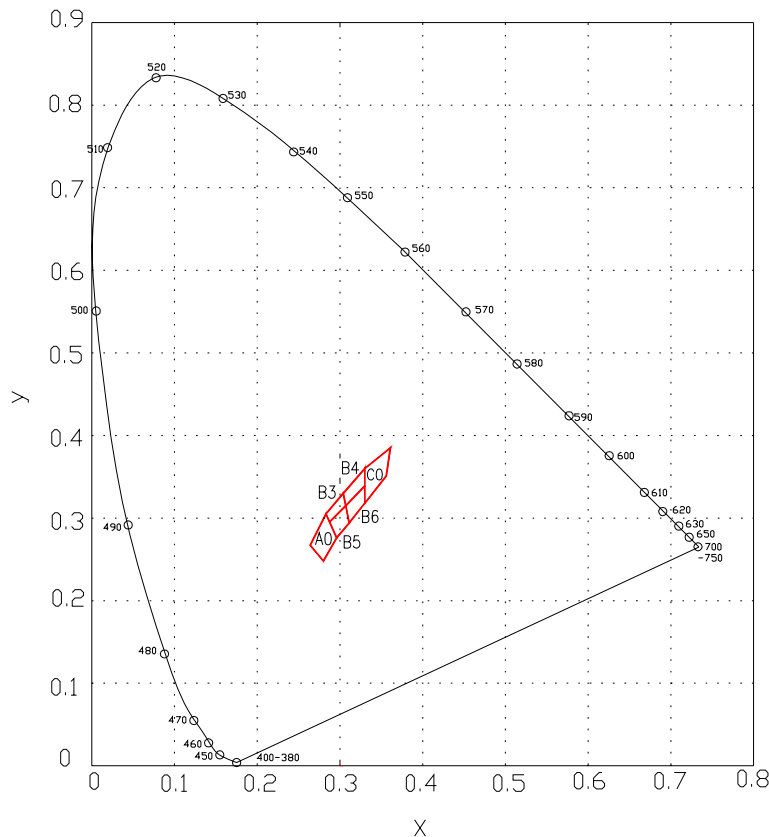
**CIE Chromaticity Diagram**

**Typical Electro-Optical Characteristics Curves**

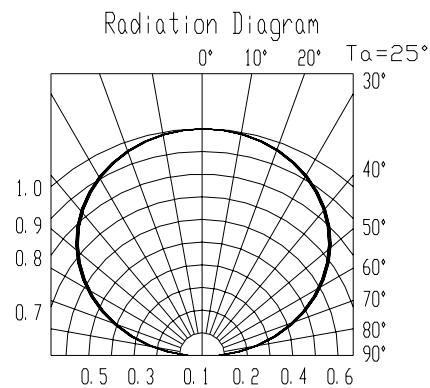
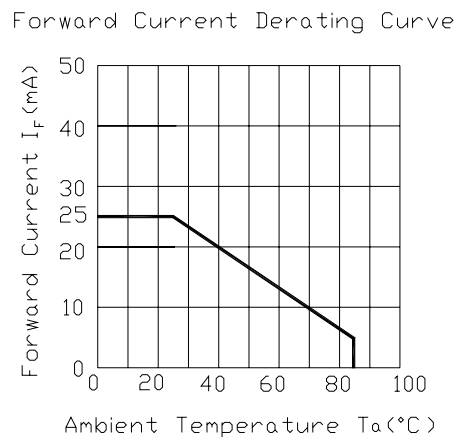
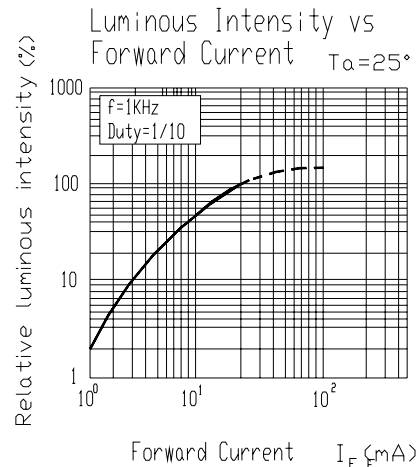
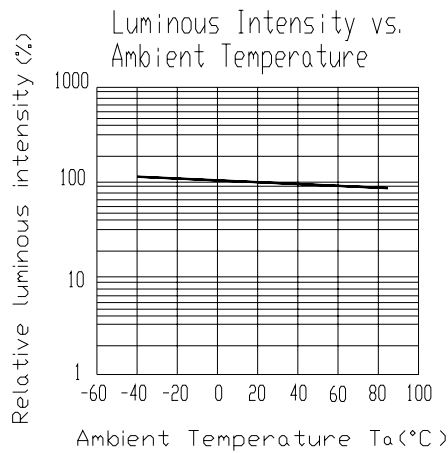
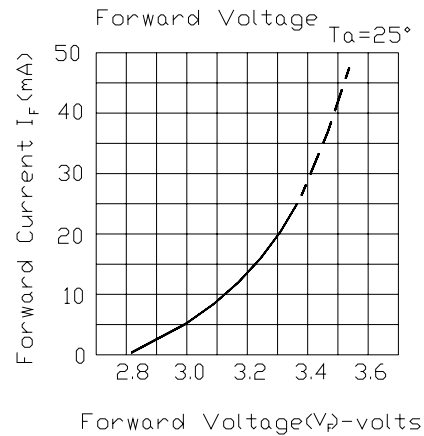
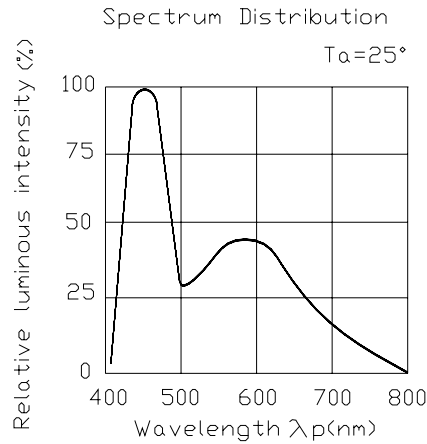

**Label explanation**

**CAT: Luminous Intensity Rank**

**HUE: Chromaticity Coordinates**

**REF: Forward Voltage Rank**

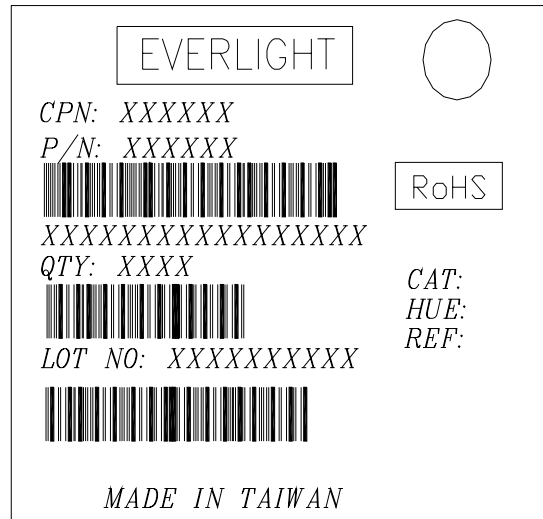

**Reel Dimensions**

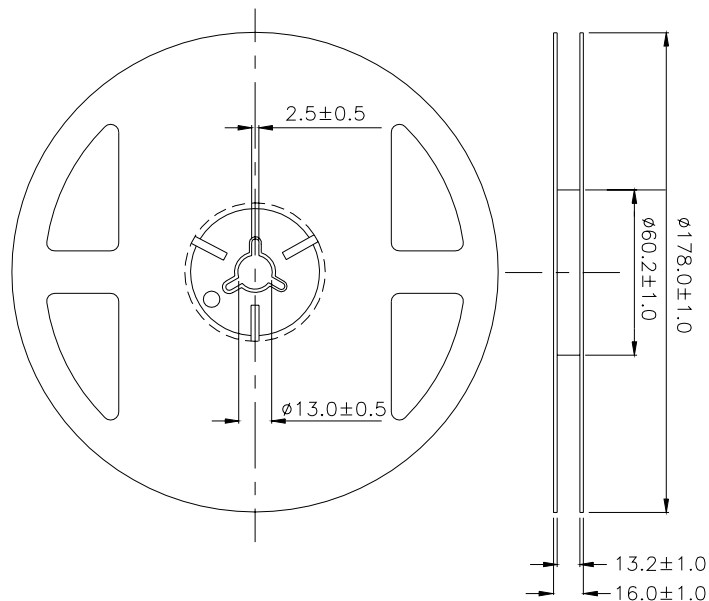

**Note:** The tolerance unless mentioned is  $\pm 0.1$ mm ,unit is mm

**Carrier Tape Dimensions: Taping Quantity: 1000 pcs**

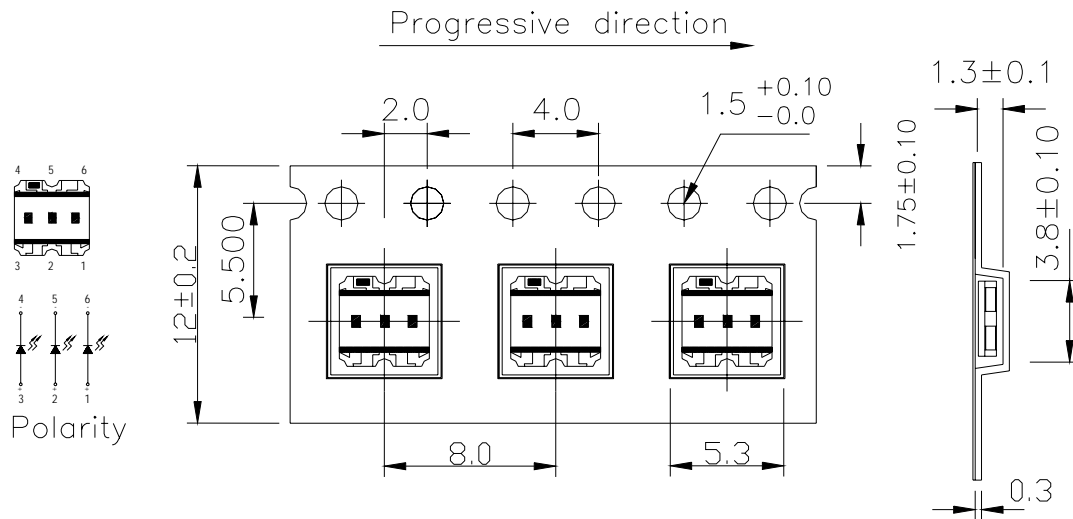

**Note:** The tolerance unless mentioned is  $\pm 0.1$ mm ,unit is mm

**Moisture Resistant Packaging**

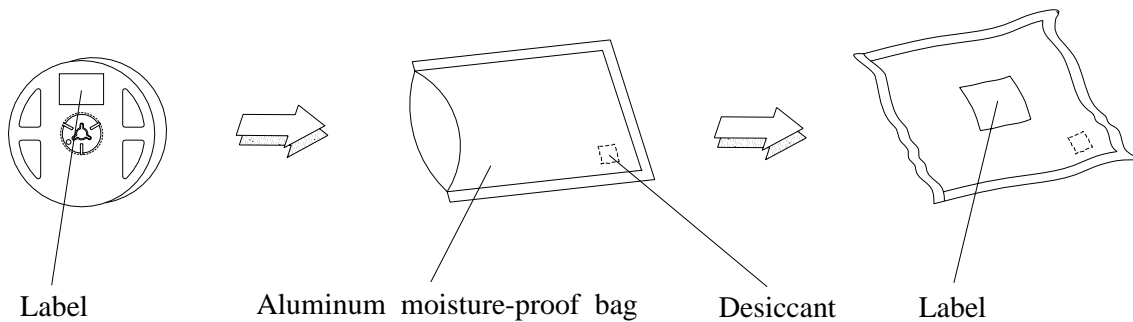

**Reliability Test Items And Conditions**

The reliability of products shall be satisfied with items listed below.

Confidence level : 90%

LTPD : 10%

No.	Items	Test Condition	Test Hours/Cycles	Sample Size	Ac/Re
1	Reflow Soldering	Temp. : 260°C±5°C Min. 5sec.	6 Min.	22 PCS.	0/1
2	Temperature Cycle	H : +100°C 15min ∫ 5 min L : -40°C 15min	300 Cycles	22 PCS.	0/1
3	Thermal Shock	H : +100°C 5min ∫ 10 sec L : -10°C 5min	300 Cycles	22 PCS.	0/1
4	High Temperature Storage	Temp. : 100°C	1000 Hrs.	22 PCS.	0/1
5	Low Temperature Storage	Temp. : -40°C	1000 Hrs.	22 PCS.	0/1
6	DC Operating Life	I <sub>F</sub> = 20 mA	1000 Hrs.	22 PCS.	0/1
7	High Temperature / High Humidity	85°C / 85%RH	1000 Hrs.	22 PCS.	0/1



## Precautions For Use

### 1. Over-current-proof

Customer must apply resistors for protection , otherwise slight voltage shift will cause big current change ( Burn out will happen ).

### 2. Storage

2.1 Do not open moisture proof bag before the products are ready to use.

2.2 Before opening the package, the LEDs should be kept at 30°C or less and 90%RH or less.

2.3 The LEDs should be used within a year.

2.4 After opening the package, the LEDs should be kept at 30°C or less and 70%RH or less.

2.5 The LEDs should be used within 168 hours (7 days) after opening the package.

2.6 If the moisture absorbent material (silica gel) has faded away or the LEDs have exceeded the storage time, baking treatment should be performed using the following conditions.

Baking treatment : 60±5°C for 24 hours.

### 3. Soldering Condition

#### 3.1 Pb-free solder temperature profile

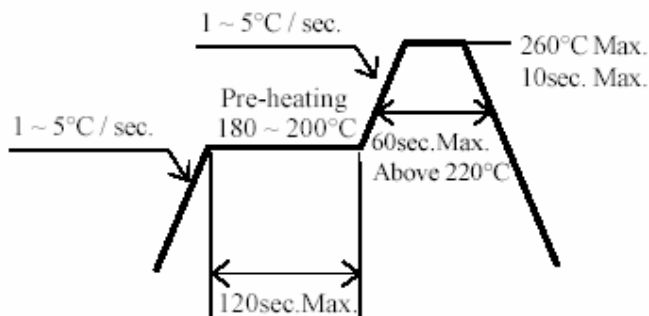

3.2 Reflow soldering should not be done more than two times.

3.3 When soldering, do not put stress on the LEDs during heating.

3.4 After soldering, do not warp the circuit board.

#### 4.Soldering Iron

Each terminal is to go to the tip of soldering iron temperature less than 350°C for 3 seconds within once in less than the soldering iron capacity 25W. Leave two seconds and more intervals, and do soldering of each terminal. Be careful because the damage of the product is often started at the time of the hand solder.

#### 5.Repairing

Repair should not be done after the LEDs have been soldered. When repairing is unavoidable, a double-head soldering iron should be used (as below figure). It should be confirmed beforehand whether the characteristics of the LEDs will or will not be damaged by repairing.

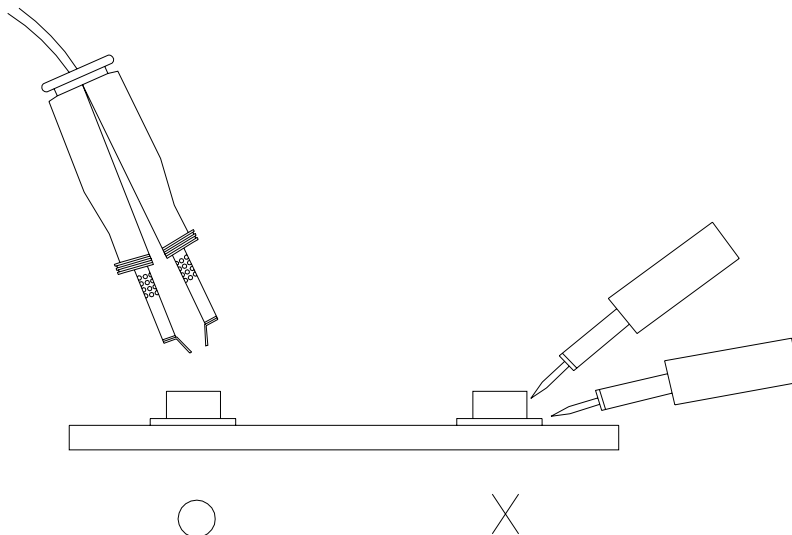

**EVERLIGHT ELECTRONICS CO., LTD.**

Office: No 25, Lane 76, Sec 3, Chung Yang Rd,  
Tucheng, Taipei 236, Taiwan, R.O.C

Tel: 886-2-2267-2000, 2267-9936

Fax: 886-2267-6244, 2267-6189, 2267-6306

<http://www.everlight.com>