



ELECTRONICS, INC.
 44 FARRAND STREET
 BLOOMFIELD, NJ 07003
 (973) 748-5089
<http://www.nteinc.com>

NTE3068 thru NTE3071 0.4" Single Digit Numeric Display Seven Segment, RHDP

Description:

The NTE3068 through NTE3071 are 0.4 inch (10.16mm) height single digit displays. The NTE3068 device utilizes LED chips which are made from GaP on a transparent GaP substrate. The NTE3070 and NTE3071 devices utilize chips which are made from GaAsP on a transparent GaP substrate.

Features:

- 0.4 Inch (10.16mm) Digit Height
- Continuous Uniform Segments
- Choice of Two Bright Colors:
 - Super Red NTE3068
 - Orange - NTE3070,
 - Amber - NTE3071
- Low Power Requirement
- Excellent Characters Appearance
- Catagorized for Luminous Intensity
- IC Compatible
- Easy Mounting on PC Board or Socket

Absolute Maximum Ratings: ($T_A = +25^\circ\text{C}$ unless otherwise specified)

Power Dissipation (Per Segment), P_T	
NTE3068, NTE3071	100mW
NTE3070,	75mW
Peak Forward Current (Per Segment, 1/10 Duty Cycle, 0.1ms Pulse Width), I_{Fpeak}	100mA
Continuous Forward Current (Per Segment), I_F	
NTE3068	40mA
NTE3070	25mA
NTE3071	35mA
Derate Linearly	
NTE3068, NTE3071 from 50°C (Per Segment)	0.40mA/ $^\circ\text{C}$
NTE3070, from 25°C (Per Segment)	0.30mA/ $^\circ\text{C}$
Reverse Voltage (Per Segment), V_R	5V
Operating Temperature Range, T_{opr}	
NTE3071	-40° to $+80^\circ\text{C}$
All Other Devices	-25° to $+85^\circ\text{C}$
Storage Temperature Range, T_{stg}	
NTE3071	-40° to $+80^\circ\text{C}$
All Other Devices	-25° to $+85^\circ\text{C}$
Lead Temperatue (During Solder, 1/16" Below Seating Plane, 3sec max), T_L	$+260^\circ\text{C}$

Electrical/Optical Characteristics: ($T_A = +25^\circ\text{C}$ unless otherwise specified)

Parameter	Symbol	Test Conditions	Min	Typ	Max	Unit
Average Luminous Intensity NTE3068	I_V	$I_F = 20\text{mA}$	-	10.5	14	md
NTE3071			6	8	10	
NTE3070		$I_F = 10\text{mA}$	850	2200	-	μcd
Peak Emission Wavelength NTE3068	λ_P	$I_F = 20\text{mA}$	655	660	665	nm
NTE3070			-	630	-	nm
NTE3071			600	605	610	nm
Spectral Line Half-Width NTE3068	$\Delta\lambda$	$I_F = 20\text{mA}$	19	24	29	nm
NTE3070			-	40	-	nm
NTE3071			35	40	45	nm
Forward Voltage, Any Segment or D.P. NTE3068	V_F	$I_F = 20\text{mA}$	1.6	1.85	2.4	V
NTE3070			-	2.1	2.8	V
NTE3071			1.7	2.1	2.5	V
Reverse Current, Any Segment or D.P.	I_R	$V_R = 5\text{V}$	-	-	100	μA
Luminous Intensity Matching Ratio	I_{V-m}	$I_F = 20\text{mA}$	-	-	2:1	

Pin Connection Diagram

NTE3068, NTE3070

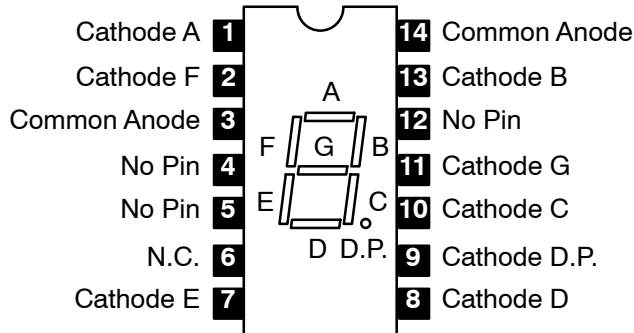

NTE3071

