

UNCONTROLLED DOCUMENT

CAUTION: STATIC SENSITIVE DEVICE  
FOLLOW PROPER E.S.D. HANDLING PROCEDURES  
WHEN WORKING WITH THIS PART.

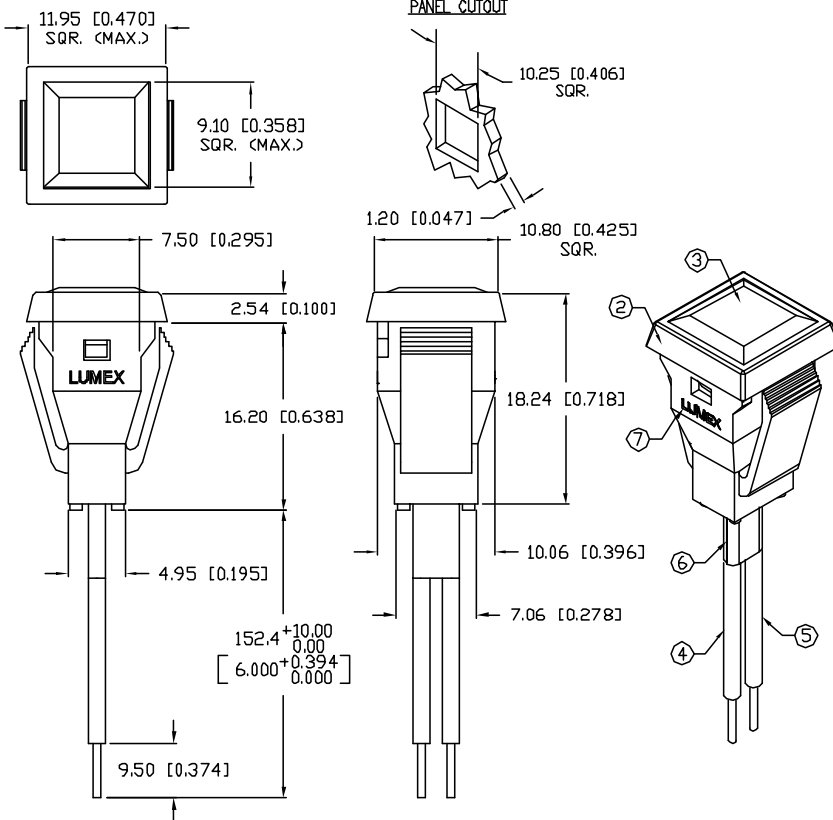

\*UNLESS OTHERWISE SPECIFIED TOLERANCES PER DECIMAL PRECISION ARE: X=±1 (±0.039), XX=±0.5 (±0.020), XXX=±0.25 (±0.010), XXXX=±0.127 (±0.005). LEAD SIZE=±0.05 (±0.002), LEAD LENGTH=±0.75 (±0.030), MIN=+DECIMAL PRECISION -0.00, MAX.=+0.00 -DECIMAL PRECISION

PART NUMBER  
SSI-LXMP5011SBC150

REV.  
A

REV.	E.C.N. NUMBER AND REVISION COMMENTS	DATE
A	E.C.N. #10808. & REDRAWN IN 3D.	11.2.01

ELECTRO-OPTICAL CHARACTERISTICS  $T_A=25^\circ\text{C}$   $I_f=20\text{mA}$

PARAMETER	MIN	TYP	MAX	UNITS	TEST COND
PEAK WAVELENGTH		430		nm	
FORWARD VOLTAGE		4.5	5.5	$V_f$	
REVERSE VOLTAGE	5.0			$V_r$	$I_f=100\mu\text{A}$
AXIAL INTENSITY		15		mcd	$I_f=20\text{mA}$
VIEWING ANGLE		60		2x theta	
EMITTED COLOR:	BLUE				
EPOXY LENS FINISH:	WATER CLEAR				

LIMITS OF SAFE OPERATION AT  $25^\circ\text{C}$

PARAMETER	MAX	UNITS
PEAK FORWARD CURRENT*	200	mA
STEADY CURRENT	30	mA
POWER DISSIPATION	105	mW
DERATE FROM $25^\circ\text{C}$	-2.0	mW/ $^\circ\text{C}$
OPERATING, STORAGE TEMP.	-40 TO +85	$^\circ\text{C}$

\*  $t < 10\mu\text{s}$

NOTES:

- SSL-LX4073SBD/A LED, BLUE. (INSIDE)
- SSH-LXMP5011 HOLDER, BLACK.
- LXP-LXN5011C, WATER CLEAR LENS.
- ANODE LEAD: LXP-WST24RDT0C, 24 AWG STRANDED, TOP OVERCOAT, RED INSULATION, CUT 160mm LONG, STRIP 4mm & 9.5mm.
- CATHODE LEAD: LXP-WST24BLT0C, 24 AWG STRANDED, TOP OVERCOAT, BLACK INSULATION, CUT 160mm LONG, STRIP 4mm & 9.5mm.
- HEAT SHRINK: LXP-HEATSHRINK-4, 1/8" x 1/2". (1 PIECE)
- 'LUMEX' ON FRONT (ANODE SIDE) OF PART.

UNCONTROLLED DOCUMENT

REV. A PART NUMBER SSI-LXMP5011SBC150

12mm SQUARE PANEL INDICATOR WITH LENS,  
430nm BLUE LED, WATER CLEAR LENS, 6" WIRE LEADS.

CONFIDENTIAL INFORMATION  
THE INFORMATION CONTAINED IN THIS DOCUMENT IS THE PROPERTY OF LUMEX INC. EXCEPT AS SPECIFICALLY AUTHORIZED IN WRITING BY LUMEX INC., THE HOLDER OF THIS DOCUMENT SHALL KEEP ALL INFORMATION CONTAINED HEREIN CONFIDENTIAL AND SHALL PROTECT SAME IN WHOLE OR IN PART FROM DISCLOSURE AND DISSEMINATION TO ALL THIRD PARTIES.

RELIABILITY NOTE  
OUR MANY YEARS OF EXPERIENCE DATA ACCUMULATION INDICATE THAT SOLDER HEAT IS A MAJOR CAUSE OF EARLY AND FUTURE FAILURE. PLEASE PAY ATTENTION TO YOUR SOLDERING PROCESS.



290 E. HELEN ROAD  
PALATINE, IL 60067-6976  
PHONE: +1.847.359.2790  
US WEB: www.lumex.com  
TW WEB: www.lumex.com.tw

DRAWN BY: BC	CHECKED BY:	APPROVED BY:	DATE: 7.1.99
			PAGE: 1 OF 1
			SCALE: N/A