

UNCONTROLLED DOCUMENT

PART NUMBER  
SSI-LXH604YD5V-150

REV.

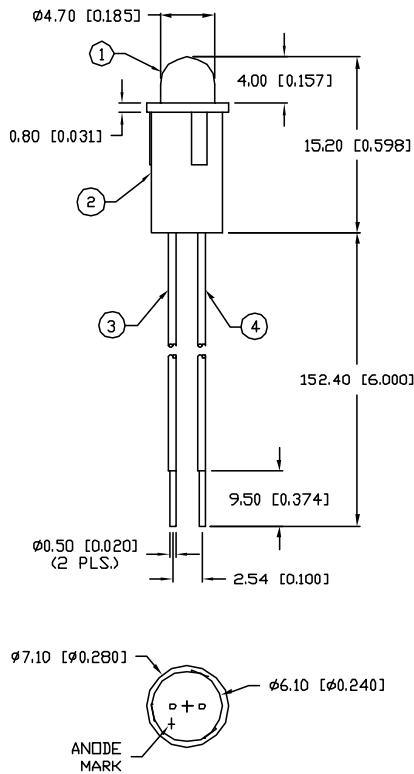

ELECTRO-OPTICAL CHARACTERISTICS  $T_A=25^\circ\text{C}$   $V_f=5\text{ V}$

PARAMETER	MIN	TYP	MAX	UNITS	TEST COND
PEAK WAVELENGTH		585		nm	
FORWARD VOLTAGE		5.0	7.0	$V_f$	
REVERSE VOLTAGE	5.0			$V_r$	$I_f=100\mu\text{A}$
AXIAL INTENSITY		10		mcd	$V_f=5\text{ V}$
VIEWING ANGLE		80		2x theta	
EMITTED COLOR:	YELLOW				
EPOXY LENS FINISH:	YELLOW DIFFUSED				

LIMITS OF SAFE OPERATION AT  $25^\circ\text{C}$

PARAMETER	MAX	UNITS
PEAK FORWARD VOLTAGE	7.0	V
STEADY CURRENT	12	mA
POWER DISSIPATION	105	mW
DERATE FROM $25^\circ\text{C}$	-1.2	mW/ $^\circ\text{C}$
OPERATING, STORAGE TEMP.	-40 TO +85	$^\circ\text{C}$
SOLDERING TEMP.	+260	$^\circ\text{C}$
2.0mm FROM BODY		3 SEC. MAX

NOTES:

1. SSL-LX509FJYD-5V, YELLOW LED.
2. SSH-LXH604 BLACK HOLDER.
3. ANODE LEAD: LXP-WST24RDT0C, RED INSULATED LEAD, 24 AWG. CUT 155mm, STRIP 3mm & 9.5mm.
4. CATHODE LEAD: LXP-WST24BLT0C, BLACK INSULATED LEAD, 24 AWG. CUT 155mm, STRIP 3mm & 9.5mm.
5. STAKE LED IN HOLDER.



UNCONTROLLED DOCUMENT

\*UNLESS OTHERWISE SPECIFIED TOLERANCES PER DECIMAL PRECISION ARE: X=±1 (±0.039), XX=±0.5 (±0.020), XXX=±0.25 (±0.010), XXXX=±0.127 (±0.005). LEAD SIZE=±0.05 (±0.002), LEAD LENGTH=±0.75 (±0.030). MIN=+DECIMAL PRECISION -0.00, MAX.=+0.00 -DECIMAL PRECISION

REV.	PART NUMBER SSI-LXH604YD5V-150	CONFIDENTIAL INFORMATION THE INFORMATION CONTAINED IN THIS DOCUMENT IS THE PROPERTY OF LUMEX INC. EXCEPT AS SPECIFICALLY AUTHORIZED IN WRITING BY LUMEX INC., THE HOLDER OF THIS DOCUMENT SHALL KEEP ALL INFORMATION CONTAINED HEREIN CONFIDENTIAL AND SHALL PROTECT SAME IN WHOLE OR IN PART FROM DISCLOSURE AND DISSEMINATION TO ALL THIRD PARTIES.		290 E. HELEN ROAD PALATINE, IL 60067-6976 PHONE: +1.847.359.2790 US WEB: www.lumex.com TW WEB: www.lumex.com.tw
	T-5mm PANEL INDICATOR, 585nm YELLOW LED, YELLOW DIFFUSED LENS, 5V OPERATION, WITH 6" WIRE LEADS.	RELIABILITY NOTE OUR MANY YEARS OF EXPERIENCE DATA ACCUMULATION INDICATE THAT SOLDER HEAT IS A MAJOR CAUSE OF EARLY AND FUTURE FAILURE. PLEASE PAY ATTENTION TO YOUR SOLDERING PROCESS.	DRAWN BY: JN	CHECKED BY: APPROVED BY: DATE: 03.20.08 PAGE: 1 OF 1 SCALE: N/A