

UNCONTROLLED DOCUMENT

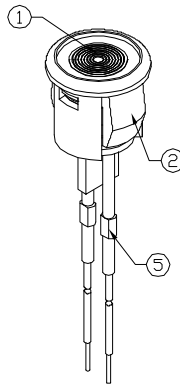
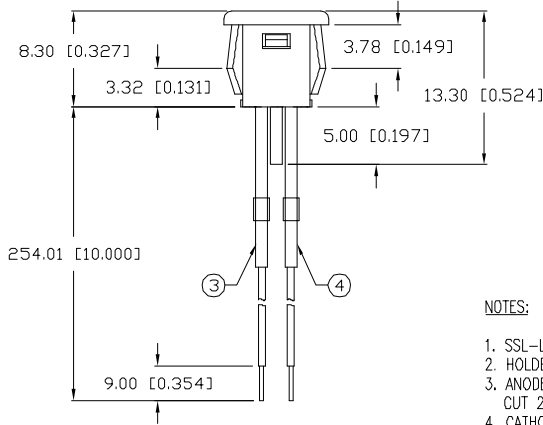
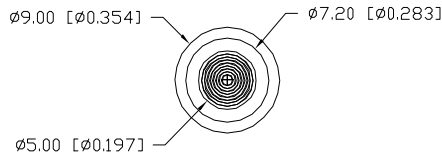

NOTES:

1. SSL-LX433GD LED.
2. HOLDER: LXP-SSI-387BSH, LXP-SSI-387BZL.
3. ANODE LEAD: LXP-WST24RDT0C STRANDED, CUT 234mm, STRIP 4mm & 9mm.
4. CATHODE LEAD: LXP-WST24BLT0C STRANDED, CUT 234mm, STRIP 4mm & 9mm.
5. CRIMP LEADS EXTERNAL TO HOUSING. HEAT SHRINK OVER CRIMP-2 PLS.
6. PANEL HOLE CUT OUT: 5/16" DIAMETER.

*UNLESS OTHERWISE SPECIFIED TOLERANCES PER DECIMAL PRECISION ARE: X=±1 (±0.039), XX=±0.5 (±0.020), XXX=±0.25 (±0.010), XXXX=±0.127 (±0.005). LEAD SIZE=±0.05 (±0.002), LEAD LENGTH=±0.75 (±0.030). MIN= +DECIMAL PRECISION -0.00, MAX= +0.00 -DECIMAL PRECISION

PART NUMBER		REV.
SSI-LXH387GD-255		A
REV.	E.C.N. NUMBER AND REVISION COMMENTS	DATE
A	E.C.N. #10BRDR. & REDRAWN.	8.2.01

ELECTRO-OPTICAL CHARACTERISTICS T _A =25°C I _f =20mA					
PARAMETER	MIN	TYP	MAX	UNITS	TEST COND
PEAK WAVELENGTH		565		nm	
FORWARD VOLTAGE		2.2	2.6	V _f	
REVERSE VOLTAGE	5.0			V _r	I _r =100µA
AXIAL INTENSITY		10		mcd	I _f =20mA
VIEWING ANGLE		120		2x theta	
EMITTED COLOR:	GREEN				
EPOXY LENS FINISH:	GREEN DIFFUSED				

LIMITS OF SAFE OPERATION AT 25°C		
PARAMETER	MAX	UNITS
PEAK FORWARD CURRENT*	150	mA
STEADY CURRENT	25	mA
POWER DISSIPATION	105	mW
DERATE FROM 25°C	-1.2	mW/°C
OPERATING, STORAGE TEMP.	-40 TO +85	°C
SOLDERING TEMP.	+260	°C
2.0mm FROM BODY		3 SEC. MAX

* t<10µS

UNCONTROLLED DOCUMENT

REV. A	PART NUMBER SSI-LXH387GD-255	<p>CONFIDENTIAL INFORMATION</p> <p>THE INFORMATION CONTAINED IN THIS DOCUMENT IS THE PROPERTY OF LUMEX INC. EXCEPT AS SPECIFICALLY AUTHORIZED IN WRITING BY LUMEX INC., THE HOLDER OF THIS DOCUMENT SHALL KEEP ALL INFORMATION CONTAINED HEREIN CONFIDENTIAL AND SHALL PROTECT SAME IN WHOLE OR IN PART FROM DISCLOSURE AND DISSEMINATION TO ALL THIRD PARTIES.</p> <p>RELIABILITY NOTE</p> <p>OUR MANY YEARS OF EXPERIENCE DATA ACCUMULATION INDICATE THAT SOLDER HEAT IS A MAJOR CAUSE OF EARLY AND FUTURE FAILURE. PLEASE PAY ATTENTION TO YOUR SOLDERING PROCESS.</p>	<p>290 E. HELEN ROAD PALATINE, IL 60067-6976 PHONE: +1.847.359.2790 US WEB: www.lumex.com TW WEB: www.lumex.com.tw</p>	<p>DRAWN BY: CT</p> <p>CHECKED BY:</p> <p>APPROVED BY:</p> <p>DATE: 10.27.97 PAGE: 1 OF 1 SCALE: N/A</p>
-----------	---------------------------------	---	--	--

T-5 FRESNEL LENS PANEL INDICATOR,
565nm GREEN LED, GREEN DIFFUSED LENS,
WITH 10" WIRE LEADS.