

REV.	E.C.N. NUMBER AND REVISION COMMENTS	DATE
A	E.C.N. #10BRDR. & REDRAWN.	1.5.99
B	E.C.N. #10702.	1.10.01

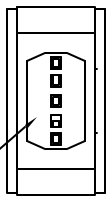
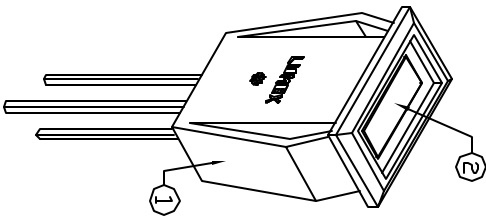
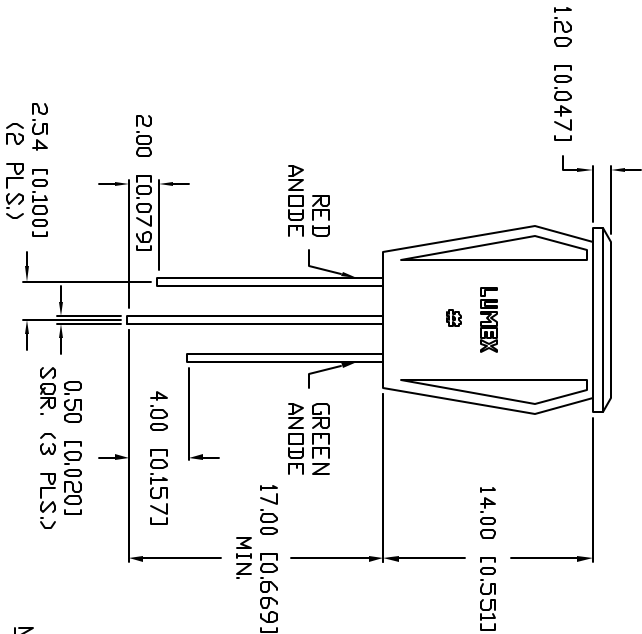
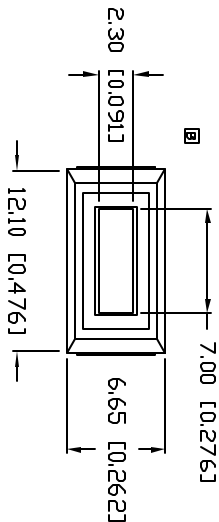

- NOTES:
1. SSH-LXH072 HOLDER, BLACK.
  2. SSI-LX25789HGW LED, RED/GREEN BICOLOR.
  3. SECURE LED TO HOLDER WITH UV ACRYLIC.
  4. PANEL CUT OUT SIZE: 5.3mm x 11.0mm.

ELECTRO-OPTICAL CHARACTERISTICS I<sub>A</sub>=25°C I<sub>F</sub>=20mA

PARAMETER	MIN	TYP	MAX	UNITS	TEST COND
PEAK WAVELENGTH		700 (RED) 565 (GREEN)		nm	
FORWARD VOLTAGE (R/G)		2.0/2.2	2.5/2.6	V <sub>F</sub>	I <sub>F</sub> =100µA
REVERSE VOLTAGE		5.0		V <sub>R</sub>	I <sub>F</sub> =20mA
AXIAL INTENSITY (R/G)		4/9		mcad	
VIEWING ANGLE		110		2x theta	
EMITTED COLOR:		RED/GREEN			
EPOXY LENS FINISH:		MILKY WHITE DIFFUSED			

LIMITS OF SAFE OPERATION AT 25°C

PARAMETER	COLORS	MAX	UNITS
PEAK FORWARD CURRENT*		150	mA
STEADY CURRENT		25	mA
POWER DISSIPATION	(R/G)	120/105	mW
DERATE FROM 25°C		-1.2	mW/°C
OPERATING, STORAGE TEMP.		-40 TO +85	°C
SOLDERING TEMP.		+260	°C
2.0mm FROM BODY			3 SEC. MAX

\* t<10µs

\*UNLESS OTHERWISE SPECIFIED TOLERANCES PER DECIMAL PRECISION ARE: X=#1 (+0.030), X#=#0.5 (+0.020), X#X=#1.25 (+0.010), XXX#=#0.127 (+0.005), LEAD SIZE=#0.08 (+0.002), LEAD LENGTH=#0.75 (+0.030), MIN.=#0.00

PART NUMBER

SSI-LXH072HGW-3LD

2.3mm x 7mm RECTANGULAR PANEL INDICATOR LED, 700nm RED/565nm GREEN BICOLOR LED, 3 LEADED, MILKY WHITE DIFFUSED LENS, COMMON CATHODE.

CONFIDENTIAL INFORMATION

THE INFORMATION CONTAINED IN THIS DOCUMENT IS THE PROPERTY OF LUMEX INC. EXCEPT AS SPECIFICALLY AUTHORIZED IN WRITING BY LUMEX INC., THE HOLDER OF THIS DOCUMENT SHALL KEEP ALL INFORMATION CONTAINED HEREIN CONFIDENTIAL AND SHALL PROTECT SAME IN WHOLE OR IN PART FROM DISCLOSURE AND REPRODUCTION TO ALL THIRD PARTIES.

RELIABILITY NOTE  
OUR MANY YEARS OF EXPERIENCE DATA ACCUMULATION INDICATE THAT SOLDER HEAT IS A MAJOR CAUSE OF EARLY AND FUTURE FAILURE. PLEASE PAY ATTENTION TO YOUR SOLDERING PROCESS.



290 E. HELEN ROAD  
PALATINE, IL 60067-6976  
PHONE: +1.847.359.2790  
US WEB: www.lumex.com  
TW WEB: www.lumex.com.tw

DRAWN BY: CT  
CHECKED BY:  
APPROVED BY:  
DATE: 1.27.97  
PAGE: 1 OF 1  
SCALE: N/A