

UNCONTROLLED DOCUMENT

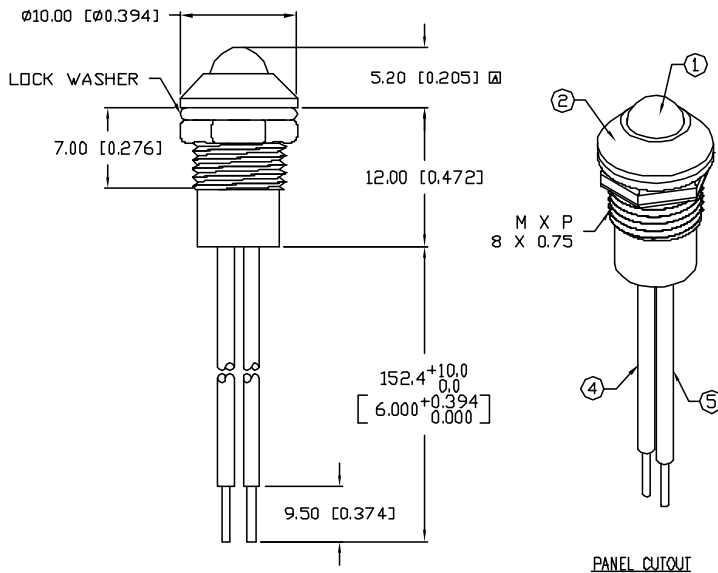

NOTES:

1. SSL-LX5093GD, GREEN LED. TRIM LEADS TO 4mm.
2. SSI-LXR3816, CHROME HOUSING.
3. SSH-LX4815BSG, BUSHING (NOT SHOWN). INSERT AND CRIMP.
4. ANODE LEAD: LXP-WST24RDT0C, 24 AWG., TINNED OVERCOAT, RED INSULATION. CUT 160mm LONG, STRIP BOTH ENDS 3mm & 9.5mm.
5. CATHODE LEAD: LXP-WST24BLT0C, 24 AWG., TINNED OVERCOAT, BLACK INSULATION. CUT 160mm LONG, STRIP BOTH ENDS 3mm & 9.5mm.
6. CRIMP WIRES TO LED LEADS.

*UNLESS OTHERWISE SPECIFIED TOLERANCES PER DECIMAL PRECISION ARE: X=±1 (±0.039), XX=±0.5 (±0.020), XXX=±0.25 (±0.010), XXXX=±0.127 (±0.005). LEAD SIZE=±0.05 (±0.002), LEAD LENGTH=±0.75 (±0.030). MIN.=^{+DECIMAL PRECISION}_{-0.00} MAX.=^{+0.00}_{-DECIMAL PRECISION}

PART NUMBER
SSI-LXR3816GD-150

REV.
A

REV.	E.C.N. NUMBER AND REVISION COMMENTS	DATE
A	E.C.N. #10810. & REDRAWN IN 3D.	11.12.01

ELECTRO-OPTICAL CHARACTERISTICS $T_A=25^{\circ}\text{C}$ $I_f=20\text{mA}$

PARAMETER	MIN	TYP	MAX	UNITS	TEST COND
PEAK WAVELENGTH		565		nm	
FORWARD VOLTAGE		2.2	2.6	V_f	
REVERSE VOLTAGE	5.0			V_r	$I_f=100\mu\text{A}$
AXIAL INTENSITY		30		mcd	$I_f=20\text{mA}$
VIEWING ANGLE		60		2x theta	
EMITTED COLOR:	GREEN				
EPOXY LENS FINISH:	GREEN DIFFUSED				

LIMITS OF SAFE OPERATION AT 25°C

PARAMETER	MAX	UNITS
PEAK FORWARD CURRENT*	150	mA
STEADY CURRENT	25	mA
POWER DISSIPATION	105	mW
DERATE FROM 25°C	-1.2	mW/°C
OPERATING, STORAGE TEMP.	-40 TO +85	°C

* $t < 10\mu\text{s}$

UNCONTROLLED DOCUMENT

REV. A	PART NUMBER SSI-LXR3816GD-150	<p>CONFIDENTIAL INFORMATION THE INFORMATION CONTAINED IN THIS DOCUMENT IS THE PROPERTY OF LUMEX INC. EXCEPT AS SPECIFICALLY AUTHORIZED IN WRITING BY LUMEX INC., THE HOLDER OF THIS DOCUMENT SHALL KEEP ALL INFORMATION CONTAINED HEREIN CONFIDENTIAL AND SHALL PROTECT SAME IN WHOLE OR IN PART FROM DISCLOSURE AND DISSEMINATION TO ALL THIRD PARTIES.</p> <p>RELIABILITY NOTE OUR MANY YEARS OF EXPERIENCE DATA ACCUMULATION INDICATE THAT SOLDER HEAT IS A MAJOR CAUSE OF EARLY AND FUTURE FAILURE. PLEASE PAY ATTENTION TO YOUR SOLDERING PROCESS.</p>	 <p>290 E. HELEN ROAD PALATINE, IL 60067-6976 PHONE: +1.847.359.2790 US WEB: www.lumex.com TW WEB: www.lumex.com.tw</p>	<p>DRAWN BY: BC</p> <p>CHECKED BY:</p> <p>APPROVED BY:</p> <p>DATE: 6.30.99 PAGE: 1 OF 1 SCALE: N/A</p>
-----------	----------------------------------	---	---	---

T-5mm 565nm GREEN LED PANEL INDICATOR,
GREEN DIFFUSED LENS, 6.0" WIRE LEADS.