

UNCONTROLLED DOCUMENT

CAUTION: PRESSURE SENSITIVE ASSEMBLY
AVOID APPLYING PRESSURE TO LED
DURING PANEL ASSEMBLY.

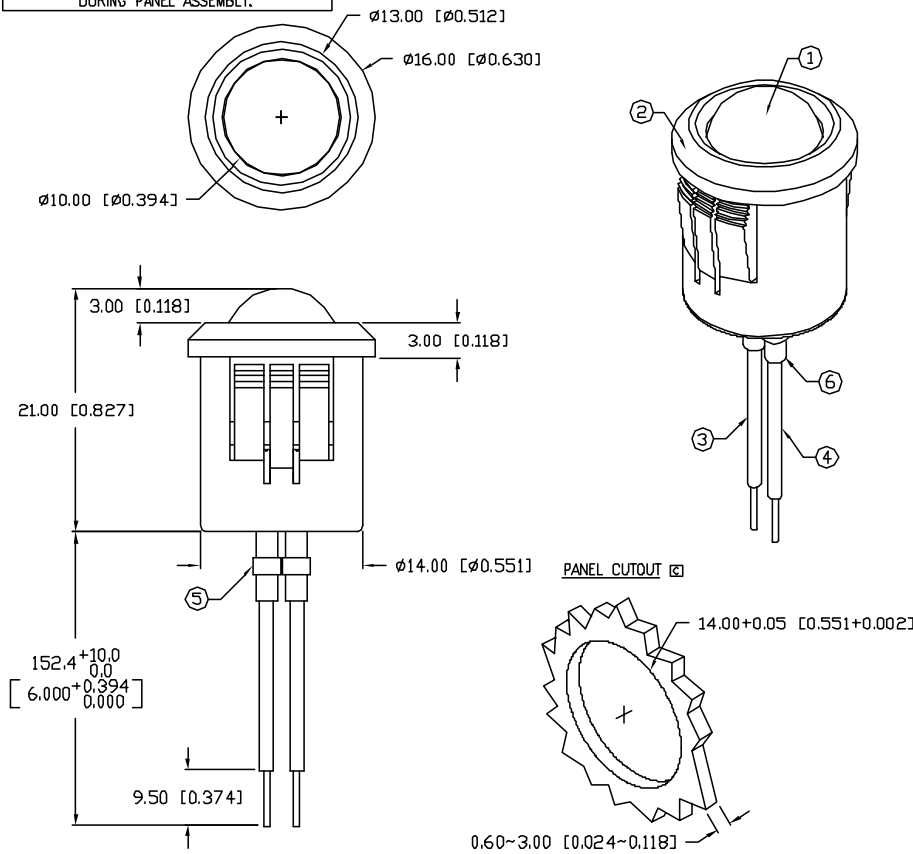

*UNLESS OTHERWISE SPECIFIED TOLERANCES PER DECIMAL PRECISION ARE: X=±1 (±0.039), XX=±0.5 (±0.020), XXX=±0.25 (±0.010), XXXX=±0.127 (±0.005). LEAD SIZE=±0.05 (±0.002), LEAD LENGTH=±0.75 (±0.030), MIN=+DECIMAL PRECISION -0.00, MAX.=+0.00 -DECIMAL PRECISION

PART NUMBER		REV.
SSI-LXH1090BID-150		D
REV.	E.C.N. NUMBER AND REVISION COMMENTS	DATE
A	E.C.N. #10BRDR.	10.9.97
B	E.C.N. #10423.	3.24.98
C	E.C.N. #10539.	9.24.99
D	E.C.N. #10BRDR. & REDRAWN IN 3D.	1.5.02

ELECTRO-OPTICAL CHARACTERISTICS $T_A=25^{\circ}\text{C}$

PARAMETER	MIN	TYP	MAX	UNITS	TEST COND
PEAK WAVELENGTH		635		nm	
FORWARD VOLTAGE	3.0	9-12	13.0	V_f	
BLINKING FREQUENCY:		1.5		Hz	$V_f=9.0, I_f=70\text{mA}$
		2.5		Hz	$V_f=3.0, I_f=6\text{mA}$
AXIAL INTENSITY		50		mcd	$V_f=9.0$
VIEWING ANGLE		60		2x theta	
EMITTED COLOR:	RED				
EPOXY LENS FINISH:	RED DIFFUSED				

LIMITS OF SAFE OPERATION AT 25°C

PARAMETER	MAX	UNITS
PEAK FORWARD CURRENT*	70	mA
STEADY CURRENT	30-56	mA
POWER DISSIPATION	200	mW
DERATE FROM 25°C	-1.2	mW/ $^{\circ}\text{C}$
OPERATING, STORAGE TEMP.	-40 TO +85	$^{\circ}\text{C}$
SOLDERING TEMP.	+260	$^{\circ}\text{C}$
2.0mm FROM BODY		3 SEC. MAX

* $t < 10\mu\text{s}$

- NOTES:
- SSL-LX100133BID LED.
 - SSH-RTF1090 HOLDER.
 - ANODE LEAD: LXP-WST24RDT0C, 24 AWG STRANDED, RED INSULATION, CUT 144mm LONG, STRIP 3mm & 9.5mm.
 - CATHODE LEAD: LXP-WST24BLT0C, 24 AWG STRANDED, BLACK INSULATION, CUT 144mm LONG, STRIP 3mm & 9.5mm.
 - CRIMP WIRE LEADS TO LED LEADS.
 - 2 PIECES- 32mm, 1/16" BLACK HEAT SHRINK TUBING.
 - UV EPOXY TO RETAIN LED IN HOLDER.

UNCONTROLLED DOCUMENT

REV.	PART NUMBER
D	SSI-LXH1090BID-150
T-10mm 635nm BLINKING RED LED PANEL INDICATOR, RED DIFFUSED LENS, 6" WIRE LEADS.	

CONFIDENTIAL INFORMATION
THE INFORMATION CONTAINED IN THIS DOCUMENT IS THE PROPERTY OF LUMEX INC. EXCEPT AS SPECIFICALLY AUTHORIZED IN WRITING BY LUMEX INC., THE HOLDER OF THIS DOCUMENT SHALL KEEP ALL INFORMATION CONTAINED HEREIN CONFIDENTIAL AND SHALL PROTECT SAME IN WHOLE OR IN PART FROM DISCLOSURE AND DISSEMINATION TO ALL THIRD PARTIES.

RELIABILITY NOTE
OUR MANY YEARS OF EXPERIENCE DATA ACCUMULATION INDICATE THAT SOLDER HEAT IS A MAJOR CAUSE OF EARLY AND FUTURE FAILURE. PLEASE PAY ATTENTION TO YOUR SOLDERING PROCESS.



290 E. HELEN ROAD
PALATINE, IL 60067-6976
PHONE: +1.847.359.2790
US WEB: www.lumex.com
TW WEB: www.lumex.com.tw

DRAWN BY:	CHECKED BY:	APPROVED BY:	DATE:
BC			7.14.93
			PAGE: 1 OF 1
			SCALE: N/A