

UNCONTROLLED DOCUMENT

PART NUMBER		REV.
SSI-LXMP059SRD-150		B
REV.	E.C.N. NUMBER AND REVISION COMMENTS	DATE
A	E.C.N. #10122.	6.28.96
B	E.C.N. #10BRDR. & REDRAWN IN 3D.	1.7.02

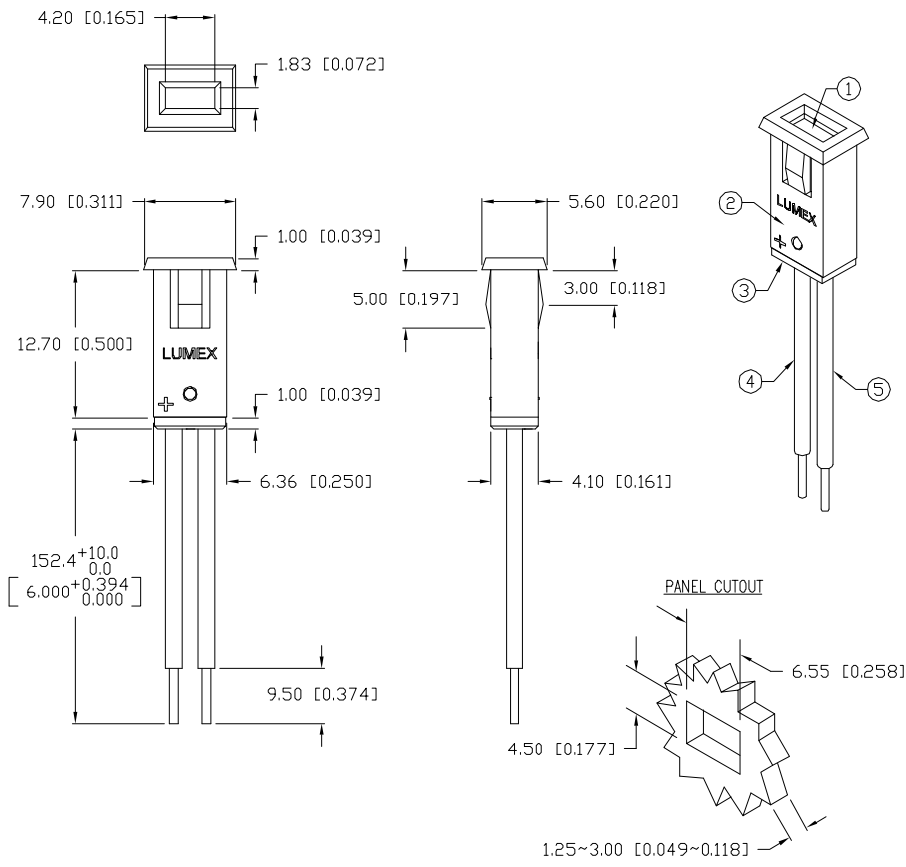

ELECTRO-OPTICAL CHARACTERISTICS $T_A=25^{\circ}\text{C}$ $I_f=20\text{mA}$

PARAMETER	MIN	TYP	MAX	UNITS	TEST COND
PEAK WAVELENGTH		660		nm	
FORWARD VOLTAGE		1.7	2.2	V _f	
REVERSE VOLTAGE	4.0			V _r	I _r =100μA
AXIAL INTENSITY		25		mcd	I _f =20mA
VIEWING ANGLE		110		2x theta	
EMITTED COLOR:	RED				
EPOXY LENS FINISH:	RED DIFFUSED				

LIMITS OF SAFE OPERATION AT 25°C

PARAMETER	MAX	UNITS
PEAK FORWARD CURRENT*	150	mA
STEADY CURRENT	30	mA
POWER DISSIPATION	105	mW
DERATE FROM 25°C	-1.2	mW/°C
OPERATING, STORAGE TEMP.	-40 TO +85	°C

* t<10μs

- NOTES:
1. SSL-LX2573SRD, RED LED. TRIM LEADS TO 3~4mm LONG.
 2. SSH-LXMP059-HSG, BLACK HOLDER.
 3. SSH-LXMP059-BSG2, BUSHING.
 4. ANODE LEAD: LXP-WST24RDT0C, RED INSULATED, 24 AWG., CUT 155mm, STRIP 3mm & 9.5mm.
 5. CATHODE LEAD: LXP-WST24BLT0C, BLACK INSULATED, 24 AWG., CUT 155mm, STRIP 3mm & 9.5mm.
 6. CRIMP OR SOLDER LEAD WIRES TO LED AND ASSEMBLE INTO HOUSING.

*UNLESS OTHERWISE SPECIFIED TOLERANCES PER DECIMAL PRECISION ARE: X=±1 (±0.039), XX=±0.5 (±0.020), XXX=±0.25 (±0.010), XXXX=±0.127 (±0.005). LEAD SIZE=±0.05 (±0.002), LEAD LENGTH=±0.75 (±0.030). MIN= +DECIMAL PRECISION MAX= +0.00 -DECIMAL PRECISION

UNCONTROLLED DOCUMENT

REV. B	PART NUMBER SSI-LXMP059SRD-150	<p>CONFIDENTIAL INFORMATION</p> <p>THE INFORMATION CONTAINED IN THIS DOCUMENT IS THE PROPERTY OF LUMEX INC. EXCEPT AS SPECIFICALLY AUTHORIZED IN WRITING BY LUMEX INC., THE HOLDER OF THIS DOCUMENT SHALL KEEP ALL INFORMATION CONTAINED HEREIN CONFIDENTIAL AND SHALL PROTECT SAME IN WHOLE OR IN PART FROM DISCLOSURE AND DISSEMINATION TO ALL THIRD PARTIES.</p> <p>RELIABILITY NOTE</p> <p>OUR MANY YEARS OF EXPERIENCE DATA ACCUMULATION INDICATE THAT SOLDER HEAT IS A MAJOR CAUSE OF EARLY AND FUTURE FAILURE. PLEASE PAY ATTENTION TO YOUR SOLDERING PROCESS.</p>	<p>290 E. HELEN ROAD PALATINE, IL 60067-6976 PHONE: +1.847.359.2790 US WEB: www.lumex.com TW WEB: www.lumex.com.tw</p>
660nm SUPER RED RECTANGULAR LED PANEL INDICATOR, RED DIFFUSED LENS, 6" WIRE LEADS.		DRAWN BY: BC	CHECKED BY:
		APPROVED BY:	DATE: 6.28.95 PAGE: 1 OF 1 SCALE: N/A