

PART NO.	H	T	F
T100 Series (T= 0.040")			
T-100-060	.060 (1.5)	.040 (1.0)	.010 (.25)
T-100-070	.070 (1.8)	.040 (1.0)	.015 (.38)
T-100-080	.080 (2.0)	.040 (1.0)	.020 (.51)
T-100-090	.090 (2.3)	.040 (1.0)	.025 (.64)
T-100-100	.100 (2.5)	.040 (1.0)	.030 (.76)
T-100-110	.110 (2.8)	.040 (1.0)	.035 (.89)
T-100-120	.120 (3.0)	.040 (1.0)	.040 (1.0)
T-100-130	.130 (3.3)	.040 (1.0)	.045 (1.1)
T-100-140	.140 (3.6)	.040 (1.0)	.050 (1.3)
T-100-150	.150 (3.8)	.040 (1.0)	.055 (1.4)
T-100-160	.160 (4.1)	.040 (1.0)	.060 (1.5)
T-100-170	.170 (4.3)	.040 (1.0)	.065 (1.7)
T-100-180	.180 (4.6)	.040 (1.0)	.070 (1.8)
T-100-190	.190 (4.8)	.040 (1.0)	.075 (1.9)
T-100-200	.200 (5.1)	.040 (1.0)	.080 (2.0)
T-100-210	.210 (5.3)	.040 (1.0)	.085 (2.2)

PART NO.	H	T	F
T101 Series (T= 0.150")			
T-101-200	.200 (5.1)	.150 (3.8)	.025 (.64)
T-101-210	.210 (5.3)	.150 (3.8)	.030 (.76)
T-101-220	.220 (5.6)	.150 (3.8)	.035 (.76)
T-101-230	.230 (5.8)	.150 (3.8)	.040 (1.0)
T-101-240	.240 (6.1)	.150 (3.8)	.045 (1.1)
T-101-250	.250 (6.4)	.150 (3.8)	.050 (1.3)
T-101-260	.260 (6.6)	.150 (3.8)	.055 (1.4)
T-101-270	.270 (6.9)	.150 (3.8)	.060 (1.5)
T-101-280	.280 (7.1)	.150 (3.8)	.065 (1.7)
T-101-290	.290 (7.4)	.150 (3.8)	.070 (1.8)
T-101-300	.300 (7.6)	.150 (3.8)	.075 (1.9)
T-101-310	.310 (7.9)	.150 (3.8)	.080 (2.0)
T-101-320	.320 (8.1)	.150 (3.8)	.085 (2.2)
T-101-330	.330 (8.4)	.150 (3.8)	.090 (2.3)
T-101-340	.340 (8.6)	.150 (3.8)	.095 (2.4)
T-101-350	.350 (8.9)	.150 (3.8)	.100 (2.5)

REV.	DESCRIPTION	DATE	APPROVED
C	Engineering Update w/o Changes	03/01/04	M. C.

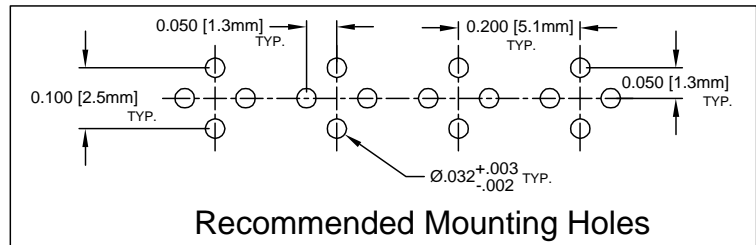
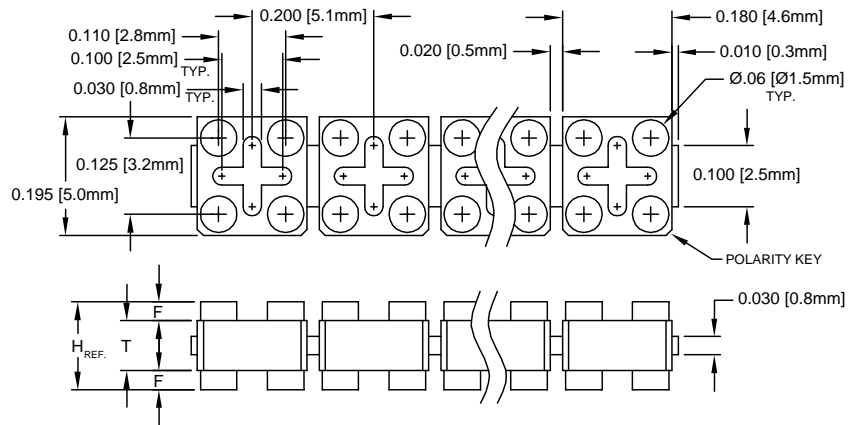

2. MATERIAL: NYLON 6/6, 94V-2, NATURAL. BIVAR MATERIAL CODE 03-NL. BASF ULTRAMID NYLON 6/6 A3K NATURAL.
1. GENERAL SPECIFICATIONS: BIVAR MOLDED COMPONENT SPECIFICATION BV00-E101.

STANDARD TOLERANCE (UNLESS OTHERWISE SPECIFIED)		 4 THOMAS, IRVINE, CA. 92618 TEL: (949) 951-8808 FAX: (949) 951-3974
DECIMALS	ANGULAR	
.X ± .1	X° ± 1°	
.XX ± .01		TITLE: 15-STATION LED STRIP-MOUNT
.XXX ± .005		
DESIGNED: David Green	DATE: 10/18/02	PART NO: T-10X-XXX
CHECKED: M. Chen	DATE: 10/22/02	
		REVISION: C
		CAGE CODE : 32559 SHEET # 1 OF 1
CAD GENERATED DOCUMENT. DO NOT MEASURE DRAWING.		