

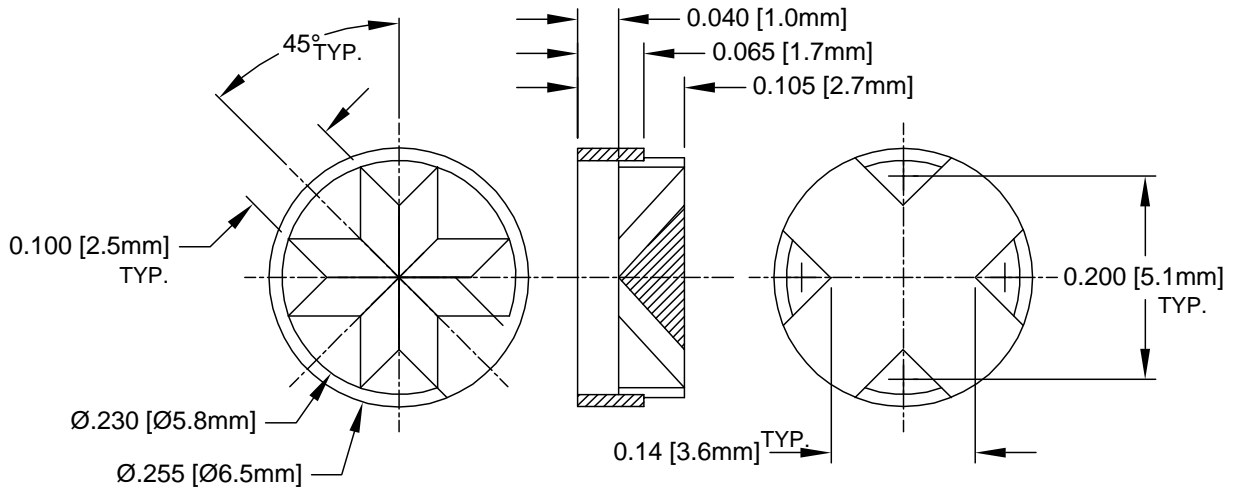

REV.	DESCRIPTION	DATE	APPROVED
C	Engineering Update w/o Changes	02/17/04	M. C.



2. MATERIAL: NYLON 6/6, 94V-2, WHITE. BIVAR MATERIAL CODE 04-WE.  
 BASF ULTRAMID NYLON 6/6 A3K WHITE.
1. GENERAL SPECIFICATIONS: BIVAR MOLDED COMPONENT SPECIFICATION BV00-E101.

STANDARD TOLERANCE (UNLESS OTHERWISE SPECIFIED)		 4 THOMAS, IRVINE, CA. 92618 TEL: (949) 951-8808 FAX: (949) 951-3974	
DECIMALS	ANGULAR		
.X ± .1	X° ± 1°		TITLE: PERM-O-PAD TO-18 MOUNT
.XX ± .01			DESIGNED: <b>Shane Irving</b> DATE: <b>07/22/98</b> PART NO: <b>213-100</b> REVISION: <b>C</b>
.XXX ± .005		CHECKED: <b>M. Chen</b> DATE: <b>01/21/03</b> CAGE CODE: <b>32559</b> SHEET # <b>1 OF 1</b>	CAD GENERATED DOCUMENT. DO NOT MEASURE DRAWING.