

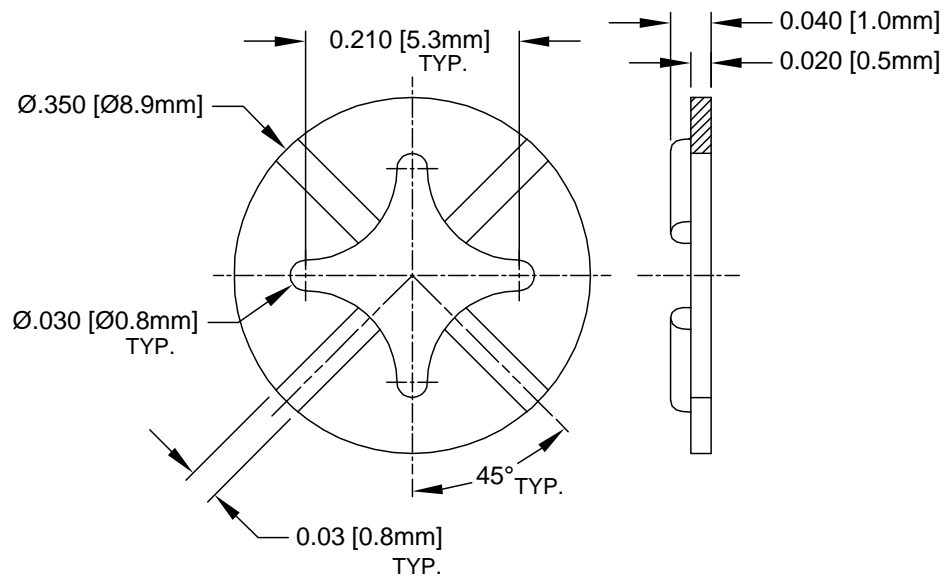

REV.	DESCRIPTION	DATE	APPROVED
A	Engineering Update w/o Changes	02/23/04	M. C.



2. MATERIAL: NYLON 6/6, 94V-2, WHITE. BIVAR MATERIAL CODE 04-WE.
 BASF ULTRAMID NYLON 6/6 A3K WHITE.
1. GENERAL SPECIFICATIONS: BIVAR MOLDED COMPONENT SPECIFICATION BV00-E101.

STANDARD TOLERANCE (UNLESS OTHERWISE SPECIFIED)		 4 THOMAS, IRVINE, CA, 92618 TEL: (949) 951-8808 FAX: (949) 951-3974			
DECIMALS	ANGULAR				
.X ± .1	X° ± 1°	TITLE: PERM-O-PAD TO-5 MOUNT REVISION: A			
.XX ± .01					
.XXX ± .005		DESIGNED: Ty Yin	DATE: 02/23/04	PART NO: 516-038	REVISION: A
CHECKED: D. Green		DATE: 02/23/04	CAGE CODE : 32559	SHEET # 1 OF 1	CAD GENERATED DOCUMENT. DO NOT MEASURE DRAWING.