

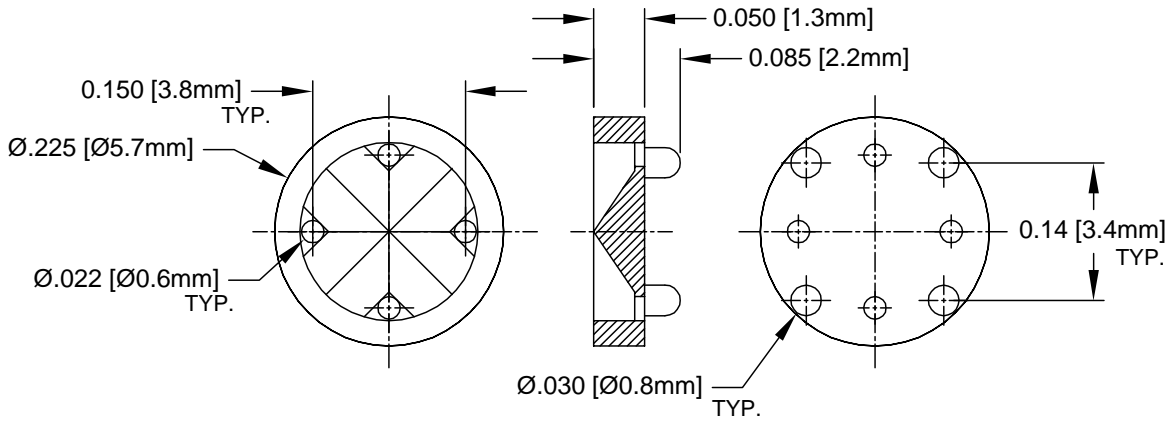

REV.	DESCRIPTION	DATE	APPROVED
A	Engineering Update w/o Changes	02/17/04	M. C.



- 2. MATERIAL: NYLON 6/6, 94V-2, WHITE. BIVAR MATERIAL CODE 04-WE.
BASF ULTRAMID NYLON 6/6 A3K WHITE.
- 1. GENERAL SPECIFICATIONS: BIVAR MOLDED COMPONENT SPECIFICATION BV00-E101.

STANDARD TOLERANCE (UNLESS OTHERWISE SPECIFIED)		 BIVAR [®] 4 THOMAS, IRVINE, CA. 92618 TEL: (949) 951-8808 FAX: (949) 951-3974	
DECIMALS	ANGULAR		
.X ± .1	X° ± 1°	TITLE: PERM-O-PAD TO-18 MOUNT PART NO: 205-085 REVISION: A	
.XX ± .01			
.XXX ± .005		DESIGNED: Shane Irving DATE: 07/16/98	CAGE CODE: 32559 SHEET # 1 OF 1 DATE: 02/17/04
		CHECKED: D. Green	CAD GENERATED DOCUMENT. DO NOT MEASURE DRAWING.