

REV.	DESCRIPTION	DATE	APPROVED
A	Engineering Release	04/10/03	M. C.
B	Engineering Update w/o Changes	01/28/05	M. C.

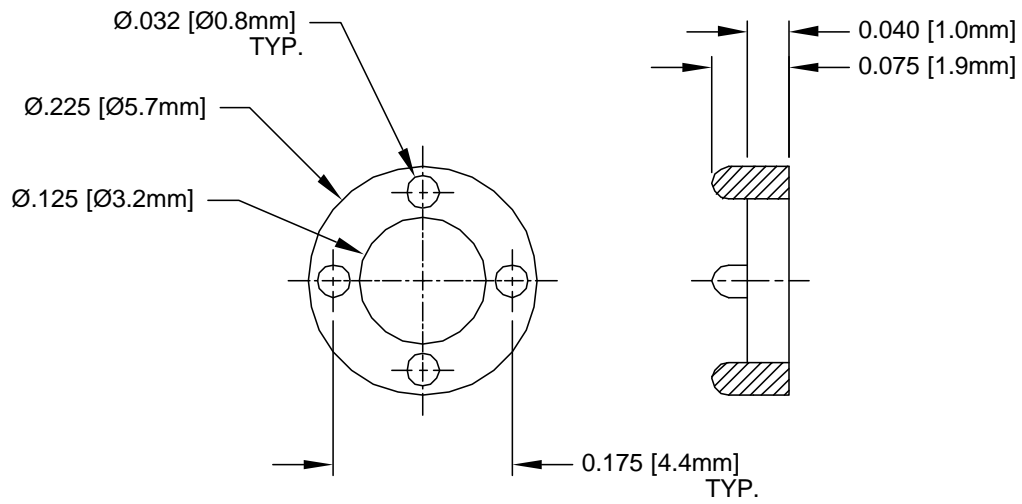

2. MATERIAL: NYLON 6/6, 94V-2, WHITE. BIVAR MATERIAL CODE 04-WE.  
 BASF ULTRAMID NYLON 6/6 A3K WHITE.
1. GENERAL SPECIFICATIONS: BIVAR MOLDED COMPONENT SPECIFICATION BV00-E101.

STANDARD TOLERANCE ( UNLESS OTHERWISE SPECIFIED )		BIVAR®	
		4 THOMAS, IRVINE, CA. 92618	
		TEL: (949) 951-8808 FAX: (949) 951-3974	
DECIMALS	ANGULAR	TITLE: PERM-O-PAD LED MOUNT	
.X ± .1	X° ± 1°	DESIGNED:	DATE:
.XX ± .01		David Green	04/10/03
.XXX ± .005		CHECKED:	DATE:
		M. Chen	04/10/03
		PART NO:	REVISION:
		103-080	B
		CAGE CODE : 32559	SHEET # 1 OF 1
CAD GENERATED DOCUMENT. DO NOT MEASURE DRAWING.			