

REV.	DESCRIPTION	DATE	APPROVED
B	Engineering Update w/o Changes	02/20/04	M. C.

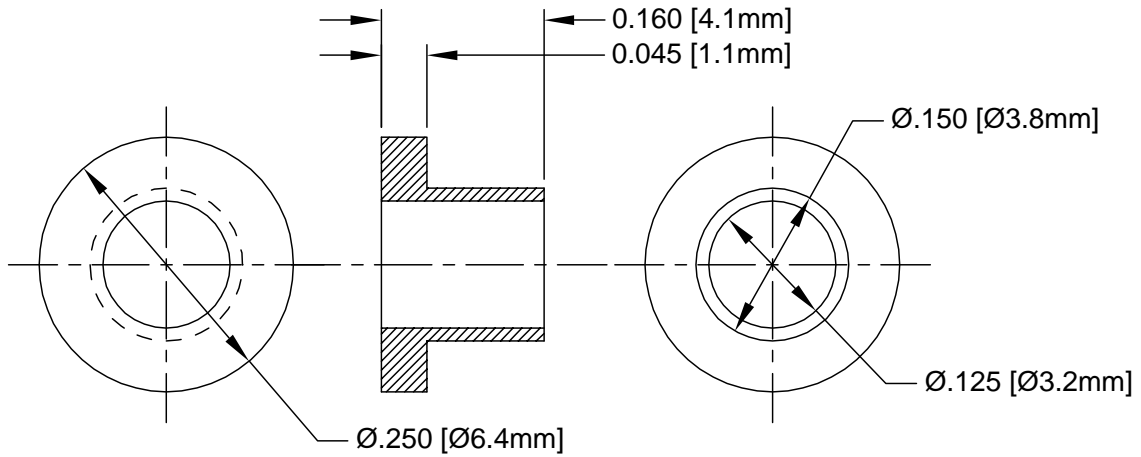

2. MATERIAL: NYLON 6/6, 94V-2, NATURAL. BIVAR MATERIAL CODE 03-NL.
 BASF ULTRAMID NYLON 6/6 A3K NATURAL.

1. GENERAL SPECIFICATIONS: BIVAR MOLDED COMPONENT SPECIFICATION BV00-E101.

STANDARD TOLERANCE (UNLESS OTHERWISE SPECIFIED)		BIVAR®	
DECIMALS	ANGULAR	4 THOMAS, IRVINE, CA. 92618	
.X ± .1	X° ± 1°	TEL: (949) 951-8808 FAX: (949) 951-3974	
.XX ± .01		TITLE: NYLON SHOULDER WASHER	
.XXX ± .005		DESIGNED: Shane Irving	DATE: 11/10/98
		CHECKED: D. Green	DATE: 02/20/04
		PART NO: 405-160	REVISION: A
		CAGE CODE: 32559	SHEET # 1 OF 1
		CAD GENERATED DOCUMENT. DO NOT MEASURE DRAWING.	