

REV.	DESCRIPTION	DATE	APPROVED
A	Engineering Update w/o Changes	02/23/04	M. C.

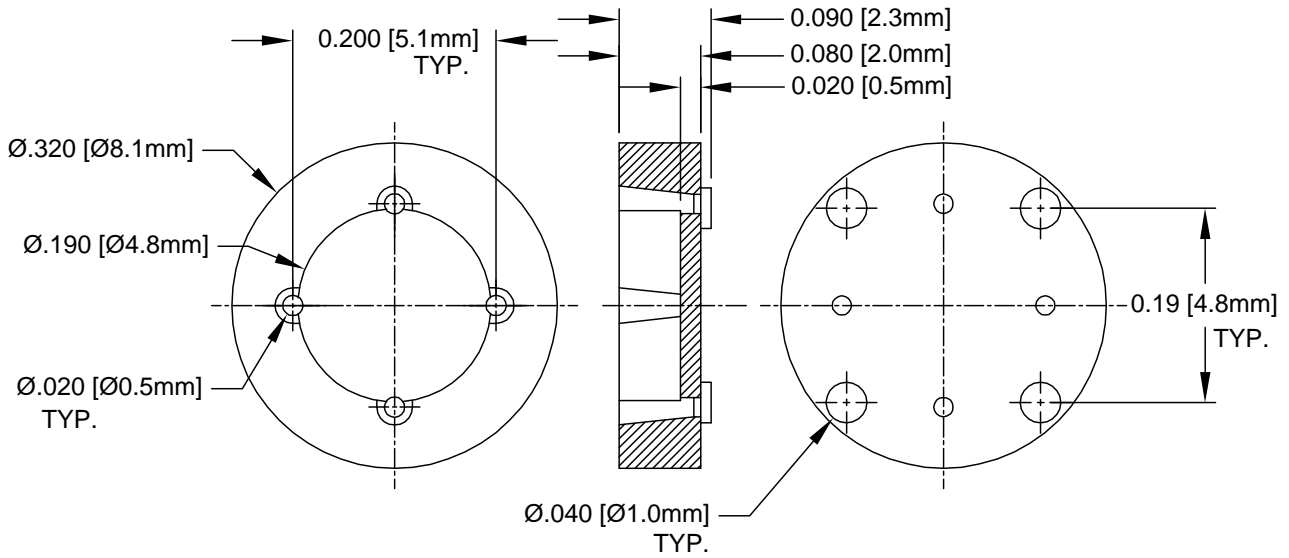

- MATERIAL: NYLON 6/6, 94V-2, NATURAL. BIVAR MATERIAL CODE 03-NL.
BASF ULTRAMID NYLON 6/6 A3K NATURAL.
- MATERIAL: NYLON 6/6, 94V-2, WHITE. BIVAR MATERIAL CODE 04-WE.
BASF ULTRAMID NYLON 6/6 A3K WHITE.
- GENERAL SPECIFICATIONS: BIVAR MOLDED COMPONENT SPECIFICATION BV00-E101.

STANDARD TOLERANCE (UNLESS OTHERWISE SPECIFIED)		BIVAR®	
DECIMALS	ANGULAR	4 THOMAS, IRVINE, CA. 92618	
.X ± .1	X° ± 1°	TEL: (949) 951-8808 FAX: (949) 951-3974	
.XX ± .01		TITLE: PERM-O-PAD TO-5 AND IC MOUNT	
.XXX ± .005		PART NO: 535-090	REVISION: A
DESIGNED: Shane Irving	DATE: 03/18/98	CAGE CODE: 32559	SHEET # 1 OF 1
CHECKED: D. Green	DATE: 02/23/04	CAD GENERATED DOCUMENT. DO NOT MEASURE DRAWING.	