

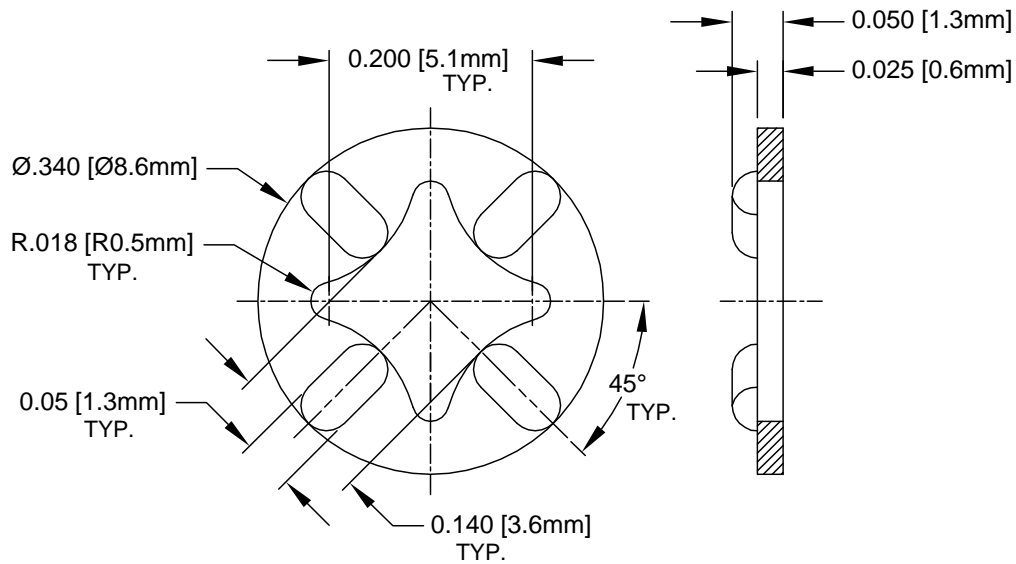

| REV. | DESCRIPTION | DATE | APPROVED |
|------|--------------------------------|----------|----------|
| A | Engineering Update w/o Changes | 02/23/04 | M. C. |
| | | | |
| | | | |
| | | | |



2. MATERIAL: NYLON 6/6, 94V-2, WHITE. BIVAR MATERIAL CODE 04-WE.
 BASF ULTRAMID NYLON 6/6 A3K WHITE.
1. GENERAL SPECIFICATIONS: BIVAR MOLDED COMPONENT SPECIFICATION BV00-E101.

| | | | |
|---|---------|---|----------------|
| STANDARD TOLERANCE (UNLESS OTHERWISE SPECIFIED) | |  4 THOMAS, IRVINE, CA. 92618 TEL: (949) 951-8808 FAX: (949) 951-3974 | |
| DECIMALS | ANGULAR | | |
| .X ± .1 | X° ± 1° | TITLE: PERM-O-PAD TO-5 MOUNT | |
| .XX ± .01 | | DESIGNED: Ty Yin | DATE: 02/23/04 |
| .XXX ± .005 | | CHECKED: D. Green | DATE: 02/23/04 |
|  | | PART NO: 532-050 | REVISION: A |
| | | CAGE CODE: 32559 | SHEET # 1 OF 1 |
| CAD GENERATED DOCUMENT. DO NOT MEASURE DRAWING. | | | |