

REV.	DESCRIPTION	DATE	APPROVED
A	Engineering Update w/o Changes	02/24/04	M. C.

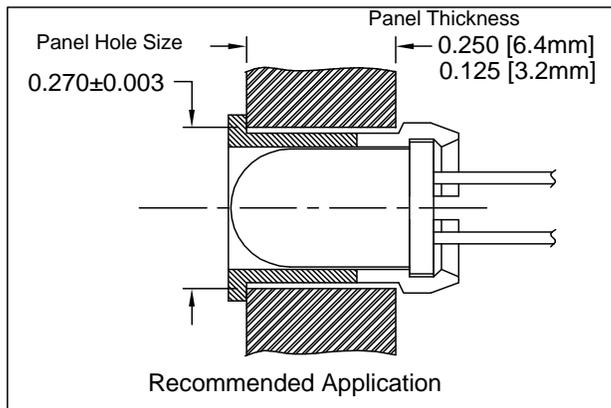
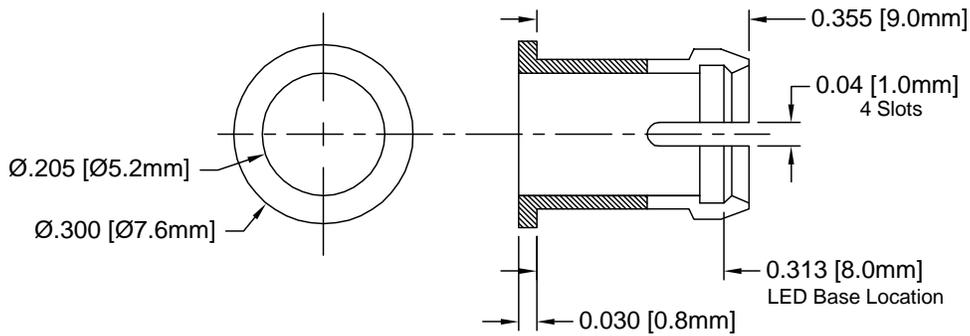

- 2. MATERIAL: NYLON 6/6, 94V-0, BLACK. BIVAR MATERIAL CODE 22-BK.  
RTP POLYAMIDE NYLON 6/6, 0200 FR, BLACK OR MODIFIED PLASTICS MN6/6-SE BK.
- 1. GENERAL SPECIFICATIONS: BIVAR MOLDED COMPONENT SPECIFICATION BV00-E101.

STANDARD TOLERANCE (UNLESS OTHERWISE SPECIFIED)		 <b>BIVAR</b> <sup>®</sup> 4 THOMAS, IRVINE, CA. 92618 TEL: (949) 951-8808 FAX: (949) 951-3974	
DECIMALS	ANGULAR		
.X ± .1	X° ± 1°	<b>TITLE:</b> T-1¼ (5mm) LED CLIP <b>REVISION:</b> A	
.XX ± .01			
.XXX ± .005		<b>DESIGNED:</b> Shane Irving <b>DATE:</b> 11/24/98 <b>PART NO:</b> C-174L	<b>CAGE CODE :</b> 32559 <b>SHEET #</b> 1 OF 1
<b>CHECKED:</b> M. Chen <b>DATE:</b> 05/17/02		CAD GENERATED DOCUMENT. DO NOT MEASURE DRAWING.	