

REV.	DESCRIPTION	DATE	APPROVED
D	Engineering Release	07/29/04	M. C.

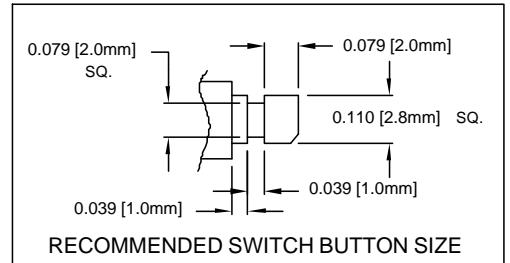
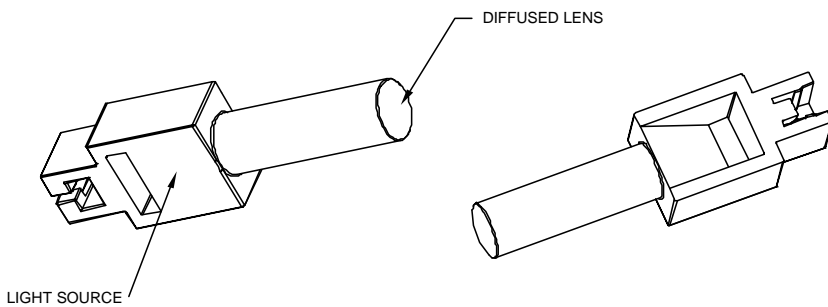
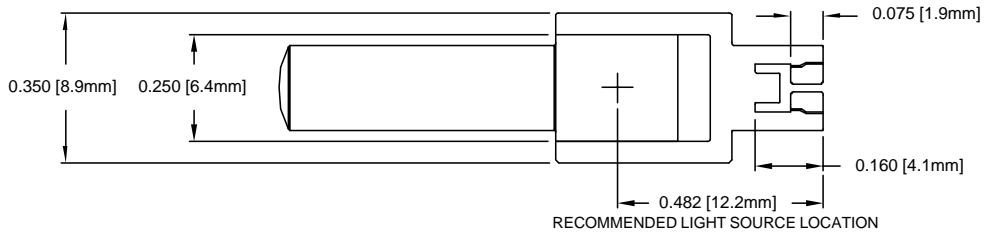
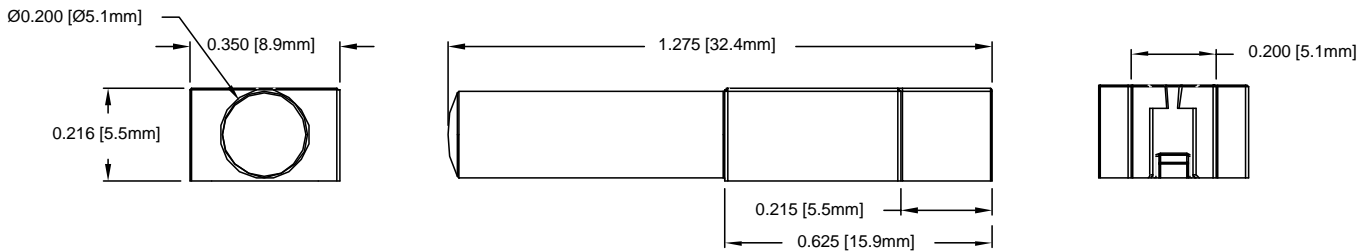

2. MATERIAL: POLYCARBONATE, 94V-0, CLEAR. BIVAR MATERIAL CODE 47-CR. SAM YANG CORPORATION POLYCARBONATE 3025N2 CLEAR.
1. GENERAL SPECIFICATIONS: BIVAR MOLDED COMPONENT SPECIFICATION BV00-E101.

STANDARD TOLERANCE (UNLESS OTHERWISE SPECIFIED)		BIVAR®	
DECIMALS	ANGULAR	4 THOMAS, IRVINE, CA. 92618	
.X ± .1	X° ± 1°	TEL: (949) 951-8808 FAX: (949) 951-3974	
.XX ± .01		TITLE: CUSTOM PUSH BUTTON LIGHT PIPE	
.XXX ± .005		DESIGNED BY: Ty Yin	DATE: 02/18/04
		CHECKED BY: M. Chen	DATE: 02/20/04
		PART NO.: PBLP-1001	REVISION: D
		CAGE CODE: 32559	SHEET # 1 OF 1
CAD GENERATED DOCUMENT. DO NOT MEASURE DRAWING.			