

UNCONTROLLED DOCUMENT

PART NUMBER  
SSF-LXH2103XID/4

REV.

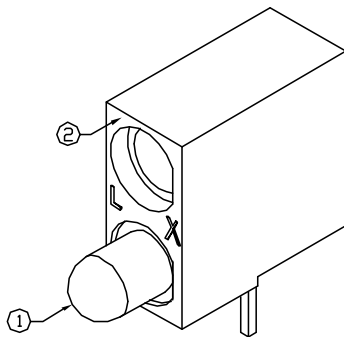
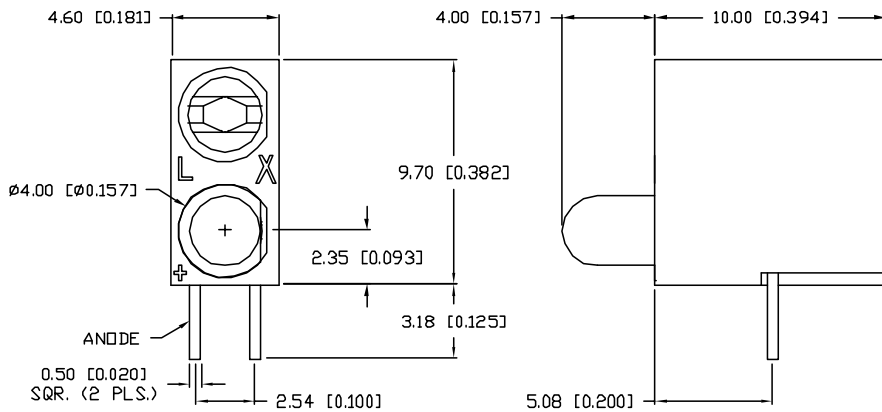

ELECTRO-OPTICAL CHARACTERISTICS  $T_A=25^{\circ}\text{C}$   $I_f=20\text{mA}$

PARAMETER	MIN	TYP	MAX	UNITS	TEST COND
PEAK WAVELENGTH		635		nm	
FORWARD VOLTAGE		2.0	2.5	$V_f$	
REVERSE VOLTAGE	5.0			$V_r$	$I_f=100\mu\text{A}$
AXIAL INTENSITY		30		mcd	$I_f=20\text{mA}$
VIEWING ANGLE		60		$2x$ theta	
EMITTED COLOR:	RED				
EPOXY LENS FINISH:	RED DIFFUSED				

LIMITS OF SAFE OPERATION AT  $25^{\circ}\text{C}$

PARAMETER	MAX	UNITS
PEAK FORWARD CURRENT*	150	mA
STEADY CURRENT	30	mA
POWER DISSIPATION	105	mW
DERATE FROM $25^{\circ}\text{C}$	-1.6	mW/ $^{\circ}\text{C}$
OPERATING, STORAGE TEMP.	-40 TO +85	$^{\circ}\text{C}$
SOLDERING TEMP.	+260	$^{\circ}\text{C}$
2.0mm FROM BODY		3 SEC. MAX

\*  $t < 10\mu\text{s}$

NOTES:

- SSL-LX3054ID, RED LED.
- SSH-LXH2103, BLACK HOLDER.

UNCONTROLLED DOCUMENT

\*UNLESS OTHERWISE SPECIFIED TOLERANCES PER DECIMAL PRECISION ARE: X= $\pm 1$  ( $\pm 0.039$ ), XX= $\pm 0.5$  ( $\pm 0.020$ ), XXX= $\pm 0.25$  ( $\pm 0.010$ ), XXXX= $\pm 0.127$  ( $\pm 0.005$ ). LEAD SIZE= $\pm 0.05$  ( $\pm 0.002$ ), LEAD LENGTH= $\pm 0.75$  ( $\pm 0.030$ ), MIN= $\frac{\text{DECIMAL PRECISION}}{1000}$ , MAX.= $\frac{+0.00}{\text{DECIMAL PRECISION}}$

REV.	PART NUMBER SSF-LXH2103XID/4
------	---------------------------------

CONFIDENTIAL INFORMATION  
THE INFORMATION CONTAINED IN THIS DOCUMENT IS THE PROPERTY OF LUMEX INC. EXCEPT AS SPECIFICALLY AUTHORIZED IN WRITING BY LUMEX INC., THE HOLDER OF THIS DOCUMENT SHALL KEEP ALL INFORMATION CONTAINED HEREIN CONFIDENTIAL AND SHALL PROTECT SAME IN WHOLE OR IN PART FROM DISCLOSURE AND DISSEMINATION TO ALL THIRD PARTIES.



290 E. HELEN ROAD  
PALATINE, IL 60067-6976  
PHONE: +1.847.359.2790  
US WEB: www.lumex.com  
TW WEB: www.lumex.com.tw

T-5mm RIGHT ANGLE FAULT INDICATOR LED,  
635nm RED LED, RED DIFFUSED LENS.

RELIABILITY NOTE  
OUR MANY YEARS OF EXPERIENCE DATA ACCUMULATION INDICATE THAT SOLDER HEAT IS A MAJOR CAUSE OF EARLY AND FUTURE FAILURE. PLEASE PAY ATTENTION TO YOUR SOLDERING PROCESS.

DRAWN BY: BC	CHECKED BY:	APPROVED BY:	DATE: 12.12.02 PAGE: 1 OF 1 SCALE: N/A
-----------------	-------------	--------------	--