

REV	ECN	APP'D
-	4520	IQ 8/21/01
A	4728	IQ 1/24/02
B	5742	RN 12/28/05

ELFP SERIES PART NUMBERING SCHEME

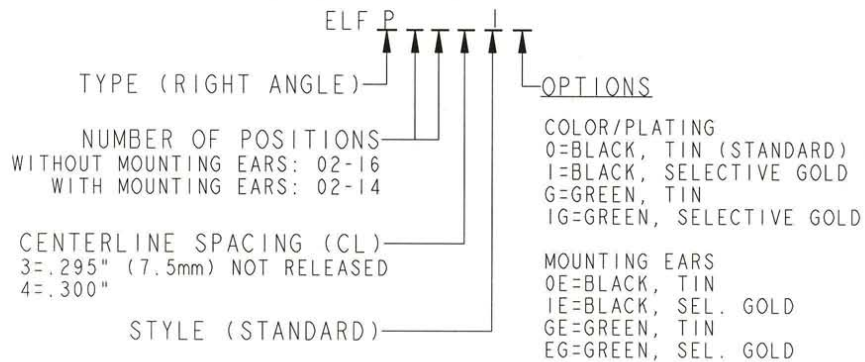

RATINGS
CURRENT - 15A
VOLTAGE - 300V
U.L. FILE NO. PENDING



RATINGS
CURRENT - 15 A
VOLTAGE - 450 V
CSA FILE NO. PENDING

DIN VDE 0627:1986
DIN VDE 0110-1:1989
EN 60947-1:1991
EN 60947-7-1:1992

CURRENT - 15 A
VOLTAGE - 450 V
TUV FILE NO. PENDING

INSTALLATION RECOMMENDATIONS:
WIRE RANGE: AWG #14-26, STRANDED
OR SOLID; AWG #12 STRANDED
WIRE STRIP LENGTH: .310"
TIGHTENING TORQUE: 7 LB-IN.

MATERIALS:
HOUSING: PPO, UL 94 V-0
CONTACT: COPPER ALLOY, OPTIONAL FINISH
SCREW: STEEL, NICKEL FINISH
WIRE CLAMP: COPPER ALLOY, NICKEL FINISH

MAX OPERATING TEMPERATURE:
105°C

DIMENSIONS ANSI Y14.5M UNITS: INCHES Pro/E FILE	TOLERANCES .XX ±0.01 .XXX ±0.005 ANGLES ±10°	PROJECTION 	Amphenol Pcd		TITLE ELFP SERIES PLUG RIGHT ANGLE 7.5mm/.300 PITCH	
			ENGR S.HORNER 30-Jul-01			
ORIGINAL STAMPED IN RED	THIS DOCUMENT CONTAINS PROPRIETARY INFORMATION WHICH IS THE CONFIDENTIAL PROPERTY OF AMPHENOL PCD, INC. PEABODY, MA, USA	CHKD IAN QUINN 21-AUG-01		SIZE A	DWG NO. ELFP02410	REV B
		APPD IAN QUINN 21-AUG-01		CODE: 58982	SCALE: NONE	SHEET 1 OF 2

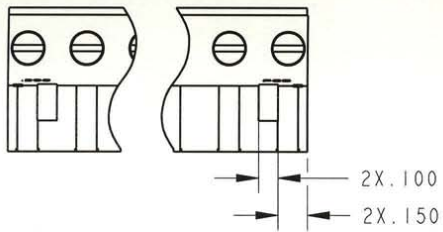

WITHOUT MOUNTING EARS

$$L = (\text{NUM OF POS} \times \text{CL}) - .1$$

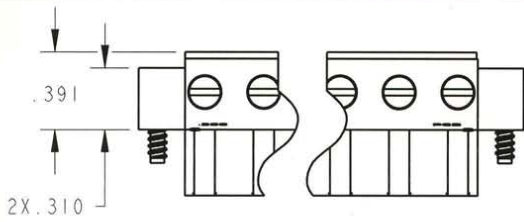
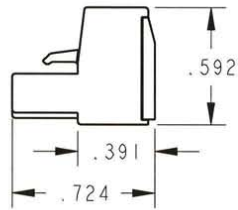
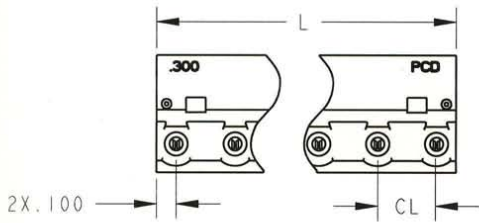

WITH MOUNTING EARS

$$L = (\text{NUM OF POS} \times \text{CL}) - .1$$

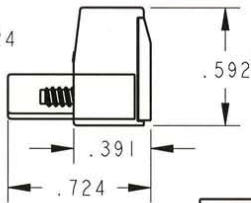
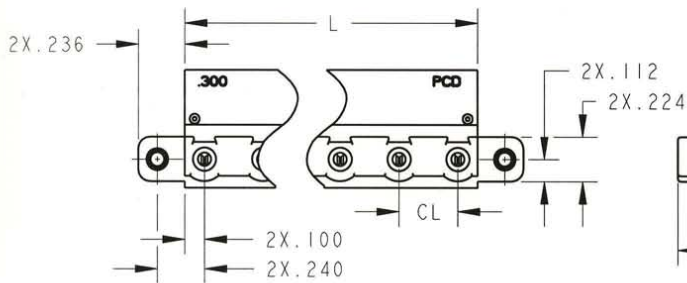

SIZE	DWG NO.	REV
A	ELFP02410	B
CODE: 58982	SCALE: NONE	SHEET 2 OF 2