

REV	DATE	DESCRIPTION	BY	CHK	APP
0		RELEASED BY: 06/28/04	06/28/04	DA	CR

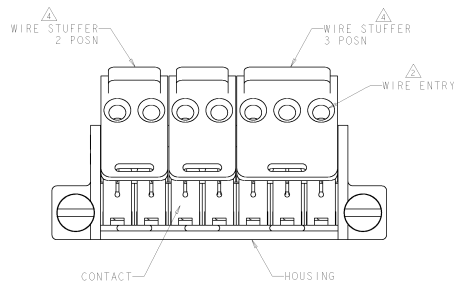
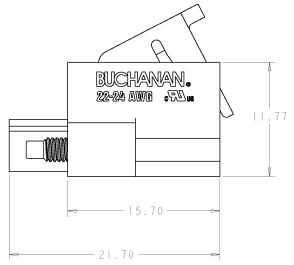
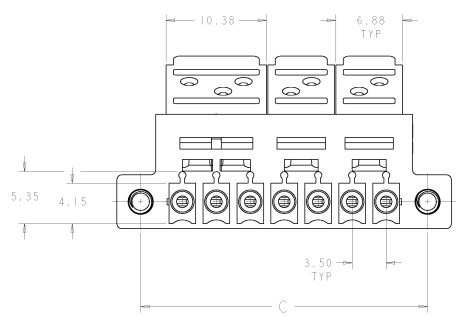
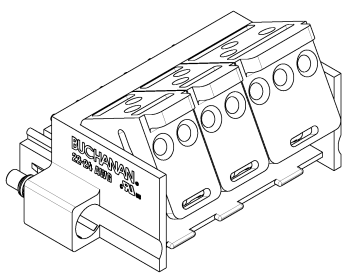
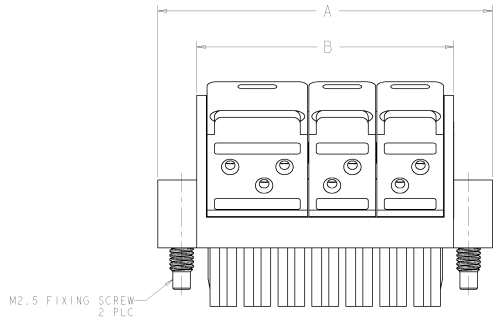

- ⚠ MATERIAL AND FINISH:
 HOUSING: POLYESTER, COLOR: GREEN.
 WIRE STUFFER: POLYCARBONATE, COLOR: CLEAR.
 CONTACT: COPPER ALLOY, 3.00µm MINIMUM TIN OVER 1.27µm NICKEL
 SCREW: STEEL, ZINC PLATED.
- ⚠ EACH WIRE ENTRY ACCEPTS ONE UNSTRIPPED, STRANDED OR SOLID COPPER 22-24 AWG WIRE WITH A MINIMUM INSULATION DIAMETER OF 1.52mm, RECOMMENDED WIRE INSULATION IS PVC. CONNECTOR MAY NOT FUNCTION CORRECTLY WITH SRPVC OR ANY OTHER RIGID OR SEMI-RIGID INSULATION. CONTACT TYCO ENGINEERING FOR ALL OTHER WIRE INSULATION APPROVAL BEFORE USE.
- 3. CONNECTOR MATES WITH 3.5mm OPEN AND CLOSED-END INDUSTRY STANDARD HEADERS.
- ⚠ ODD POSITION ASSEMBLIES USE ONE 3 POSITION WIRE STUFFER LOCATED OVER THE LAST THREE POSITIONS AS SHOWN AND 2-POSITION WIRE STUFFERS FOR REMAINING POSITIONS.
- 5. ASSEMBLIES SHIPPED WITH WIRE STUFFERS IN THE OPEN POSITION.

61.10	58.00	66.00	16	I-1776283-6
57.60	54.50	62.50	15	I-1776283-5
54.10	51.00	59.00	14	I-1776283-4
50.60	47.50	55.50	13	I-1776283-3
47.10	44.00	52.00	12	I-1776283-2
43.60	40.50	48.50	11	I-1776283-1
40.10	37.00	45.00	10	I-1776283-0
36.60	33.50	41.50	9	I776283-9
33.10	30.00	38.00	8	I776283-8
29.60	26.50	34.50	7	I776283-7
26.10	23.00	31.00	6	I776283-6
22.60	19.50	27.50	5	I776283-5
19.10	16.00	24.00	4	I776283-4
15.60	12.50	20.50	3	I776283-3
12.10	9.00	17.00	2	I776283-2

C	B	A	NO OF POSN	PART NUMBER
61.10	58.00	66.00	16	I-1776283-6
57.60	54.50	62.50	15	I-1776283-5
54.10	51.00	59.00	14	I-1776283-4
50.60	47.50	55.50	13	I-1776283-3
47.10	44.00	52.00	12	I-1776283-2
43.60	40.50	48.50	11	I-1776283-1
40.10	37.00	45.00	10	I-1776283-0
36.60	33.50	41.50	9	I776283-9
33.10	30.00	38.00	8	I776283-8
29.60	26.50	34.50	7	I776283-7
26.10	23.00	31.00	6	I776283-6
22.60	19.50	27.50	5	I776283-5
19.10	16.00	24.00	4	I776283-4
15.60	12.50	20.50	3	I776283-3
12.10	9.00	17.00	2	I776283-2

BUCHANAN ELECTRONICS CORPORATION	BUCHANAN ELECTRONICS CORPORATION	BUCHANAN ELECTRONICS CORPORATION	BUCHANAN ELECTRONICS CORPORATION
REV: 01	REV: 01	REV: 01	REV: 01
DATE: 06/28/04	DATE: 06/28/04	DATE: 06/28/04	DATE: 06/28/04
BY: DAVID A. CRONIN	BY: DAVID A. CRONIN	BY: DAVID A. CRONIN	BY: DAVID A. CRONIN
CHK: DAVID A. CRONIN	CHK: DAVID A. CRONIN	CHK: DAVID A. CRONIN	CHK: DAVID A. CRONIN
APP: DAVID A. CRONIN	APP: DAVID A. CRONIN	APP: DAVID A. CRONIN	APP: DAVID A. CRONIN
REV: 01	REV: 01	REV: 01	REV: 01
DATE: 06/28/04	DATE: 06/28/04	DATE: 06/28/04	DATE: 06/28/04
BY: DAVID A. CRONIN	BY: DAVID A. CRONIN	BY: DAVID A. CRONIN	BY: DAVID A. CRONIN
CHK: DAVID A. CRONIN	CHK: DAVID A. CRONIN	CHK: DAVID A. CRONIN	CHK: DAVID A. CRONIN
APP: DAVID A. CRONIN	APP: DAVID A. CRONIN	APP: DAVID A. CRONIN	APP: DAVID A. CRONIN