

NUMBER C-1470199
 METRIC
 3RD ANGLE PROJECTION
 THIS INFORMATION IS CONFIDENTIAL AND IS PROVIDED TO YOU ON CONFIDENCE. IT IS NOT TO BE REPRODUCED OR TRANSMITTED IN ANY FORM OR BY ANY MEANS, ELECTRONIC OR MECHANICAL, INCLUDING PHOTOCOPYING, RECORDING, OR BY ANY INFORMATION STORAGE AND RETRIEVAL SYSTEM, WITHOUT THE WRITTEN PERMISSION OF AMP. DIMENSIONS IN MILLIMETERS. DO NOT SCALE PRINT.
 PRINT DW

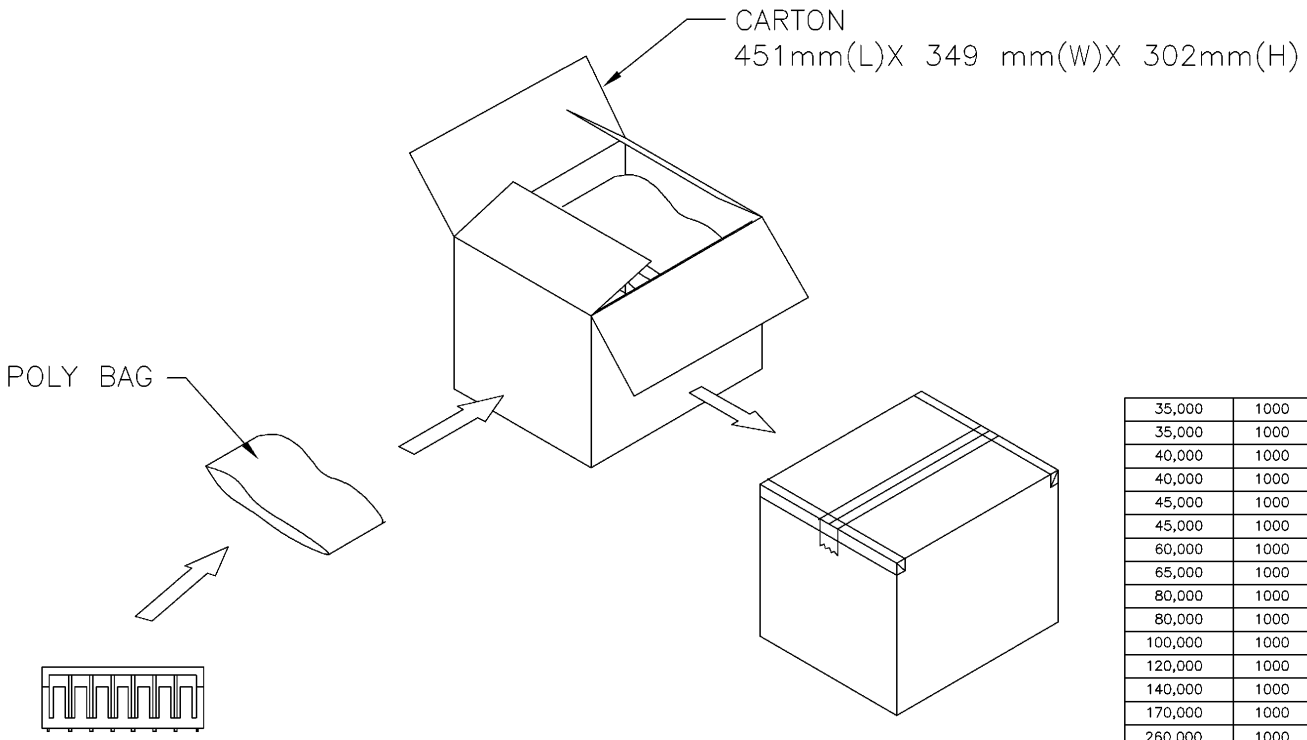

APQ (PCS/CARTON)	PPQ (PCS/BAG)	PART NUMBER
35,000	1000	1-1470199-6
35,000	1000	1-1470199-5
40,000	1000	1-1470199-4
40,000	1000	1-1470199-3
45,000	1000	1-1470199-2
45,000	1000	1-1470199-1
60,000	1000	1-1470199-0
65,000	1000	1470199-9
80,000	1000	1470199-8
80,000	1000	1470199-7
100,000	1000	1470199-6
120,000	1000	1470199-5
140,000	1000	1470199-4
170,000	1000	1470199-3
260,000	1000	1470199-2

DIMENSION :	DWN	O. HUI	AMP TYCO HOLDINGS (BERMUDA) VII LTD. TAIWAN BRANCH
0 PLC #	16-JULY-2002	J. CHENG	
1 PLC #	CHK	J. CHENG	NAME
2 PLC #	APVD	J. WU	2.0 MM PITCH, CRIMP, RIGHT ANGLE, HOUSING
3 PLC #	16-JULY-2002	PRODUCT SPEC	
ANGLES #	FINISH	SEE NOTE	LOC DW
	APPLICATION SPEC	SEE NOTE	SCALE
	WEIGHT		DRAWING NO
			C-1470199
			REV
			0
			SHEET
			2 OF 2

SEE SHEET 1.	ECN	DWN	DATE
LTR	REVISION RECORD	CHK	

CUSTOMER DRAWING