

Fig. 1

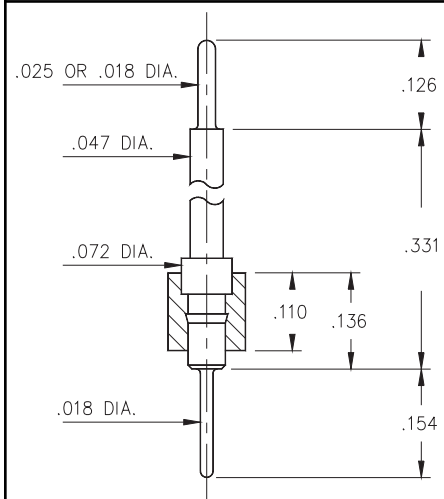

Fig. 2

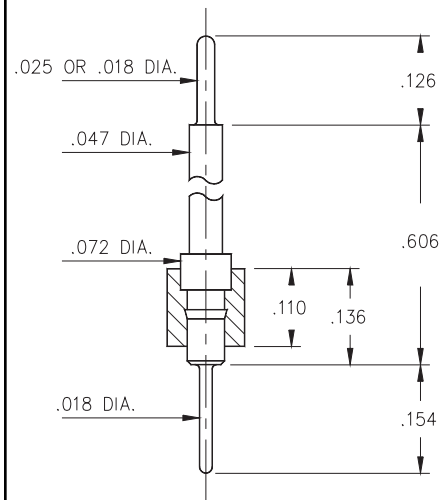

Fig. 3

- Series 351 Interconnect header strips come in three lengths with .018" dia. pluggable solder tails at one end and .025" dia. pins at the other, see series:
351...003 uses pin #5503
351...004 uses pin #5504
351...005 uses pin #5505
- .018" pluggable solder tails are available at both ends, please see series:
351...009 uses pin #5509
351...010 uses pin #5510
351...011 uses pin #5511
See pages 179 & 181 for details.
- Insulators are high temp. thermoplastic.



Ordering Information

Fig. 1	Series 351...003 .018 / .025 Solder Tails
	351-10-1__-00-003000 Specify # of pins → 01-64
Fig. 2	Series 351...009 .018 / .018 Solder Tails
	351-10-1__-00-009000 Specify # of pins → 01-64
Fig. 3	Series 351...004 .018 / .025 Solder Tails
	351-10-1__-00-004000 Specify # of pins → 01-64
Fig. 3	Series 351...010 .018 / .018 Solder Tails
	351-10-1__-00-010000 Specify # of pins → 01-64
Fig. 3	Series 351...005 .018 / .025 Solder Tails
	351-10-1__-00-005000 Specify # of pins → 01-64
Fig. 3	Series 351...011 .018 / .018 Solder Tails
	351-10-1__-00-011000 Specify # of pins → 01-64

For Electrical, Mechanical & Environmental Data, See pg. 4

For RoHS compliance select \diamond plating code.

PLATING CODE =	10 \diamond		
Pin Plating	10 μ " Au		