

LOC	DIST	REVISIONS					
		P	LTR	DESCRIPTION	DATE	DWN	APVD
—	—		A	REDRAWN PER ECO-08-023052	30SEP08	HMR	SM

1 MATERIAL: NYLON

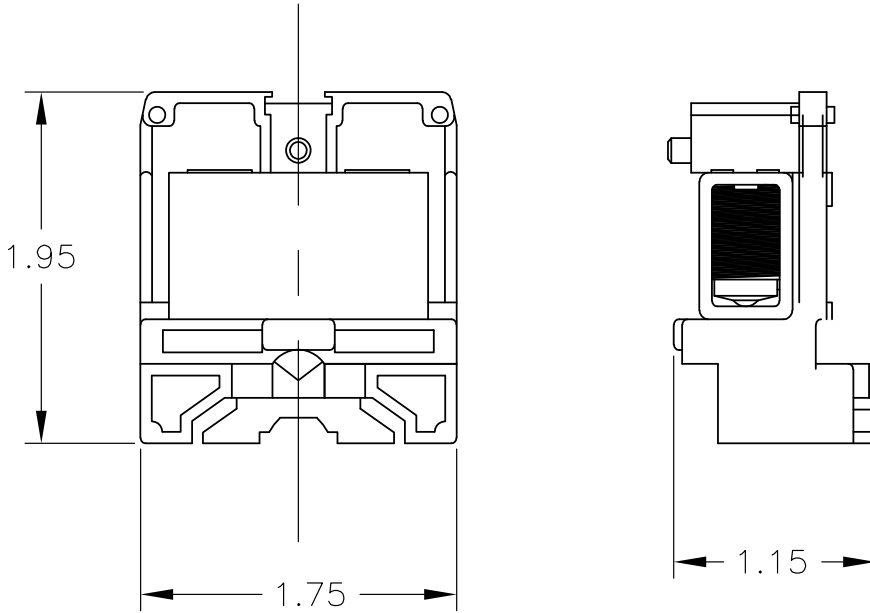

THIS DRAWING IS UNPUBLISHED.
 ALL INTERNATIONAL RIGHTS RESERVED.
 BY TYCO ELECTRONICS CORPORATION.

824-BU	1437395-3
814	1437395-2
CATALOG P/N	PART NUMBER

DIMENSIONS: INCHES TOLERANCES UNLESS OTHERWISE SPECIFIED: 0 PLC ± - 1 PLC ± - 2 PLC ± - 3 PLC ± .010 4 PLC ± - ANGLES ± -	DWN RAGHAVENDRA 30SEP08 CHK MACE SAM 30SEP08 APVD MACE SAM 30SEP08	MATERIAL 1 FINISH -	Tyco Electronics Corporation Harrisburg, PA 17105-3608
	PRODUCT SPEC - APPLICATION SPEC - WEIGHT -	NAME ASSEMBLY, TERMINAL BLOCK, NEMA DOVETAIL BASE, HEAVY DUTY, TUBULAR SCREW	SIZE A4 CAGE CODE 00779 DRAWING NO C-1437395-2
CUSTOMER DRAWING		SCALE 1:1	SHEET 1 OF 1 REV A