

LOC	DIST	REVISIONS					
		P	LTR	DESCRIPTION	DATE	DWN	APVD
—	—		A	REDRAWN PER ECO-08-023052	29SEP08	HMR	SM

△ 1 MATERIAL: NYLON

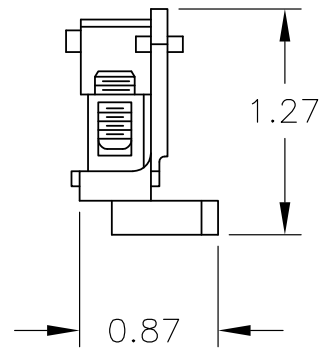
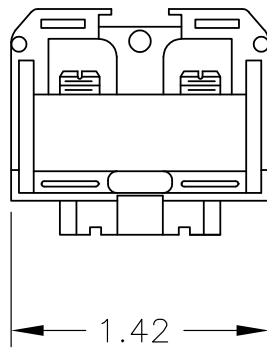

THIS DRAWING IS UNPUBLISHED.  
 ALL INTERNATIONAL RIGHTS RESERVED.  
 © COPYRIGHT BY TYCO ELECTRONICS CORPORATION.

DIMENSIONS: INCHES	DWN	RAGHAVENDRA	29SEP08	MATERIAL	△ 1	FINISH	—
	CHK	MACE SAM	29SEP08	Tyco Electronics Corporation Harrisburg, PA 17105-3608			
TOLERANCES UNLESS OTHERWISE SPECIFIED:			APVD				
0 PLC	± -	PRODUCT SPEC		NAME			
1 PLC	± -	—		HEAVY DUTY, T.S., NYLON			
2 PLC	± -	APPLICATION SPEC		F.B. TERMINAL BLOCK ASS'Y			
3 PLC	± -	—		SIZE	A4	CAGE CODE	00779
4 PLC	± -	WEIGHT		DRAWING NO	C-4-1437390-0		RESTRICTED TO
ANGLES	± -	—		SCALE		1:1	SHEET
				CUSTOMER DRAWING		1 OF 1	REV
						A	