

10 9 8 7 6 5 4 3 2 38002

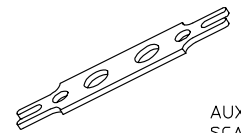
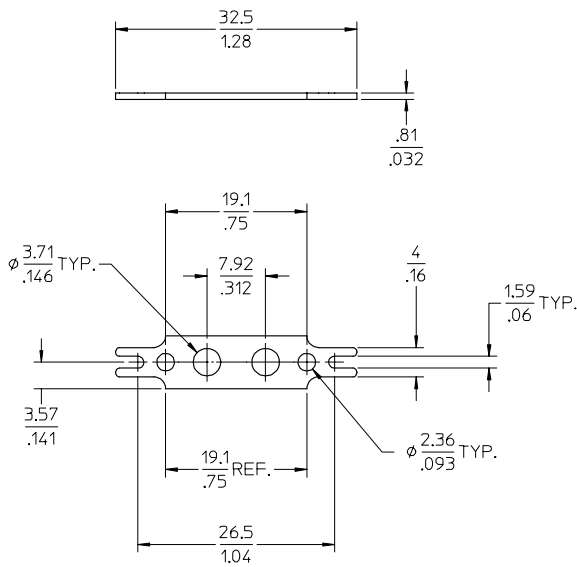

AUX.VIEW  
SCALE: 2X

NOTES:

1. MATERIAL: SEE TABLE
2. FINISHES: SEE TABLE
3. PRODUCT SPECIFICATION: NOT REQUIRED
4. MATES WITH: NONE

1	1	TERMINAL	BRASS	TIN PLATED
ITEM	QTY.	DESCRIPTION	MATERIAL	FINISH

EC NO: NEO2004-0507 DRAWN BY: R.STONE 2004/02/03 CHECKED BY: G.ROBERT 2004/02/10 APPR: G.ROBERT 2004/02/10	QUALITY SYMBOLS	GENERAL TOLERANCES (UNLESS SPECIFIED)	SCALE 2:1	DESIGN UNITS INCH	THIRD ANGLE PROJECTION	REVISE ON CAD ONLY															
	▽ -0 ▽ -0	<table border="1"> <tr> <th></th> <th>mm</th> <th>INCH</th> </tr> <tr> <td>4 PLACES</td> <td>± ---</td> <td>± .0015</td> </tr> <tr> <td>3 PLACES</td> <td>± 0.038</td> <td>± .005</td> </tr> <tr> <td>2 PLACES</td> <td>± 0.13</td> <td>± .010</td> </tr> <tr> <td>1 PLACE</td> <td>± 0.3</td> <td>± ---</td> </tr> </table>		mm	INCH	4 PLACES	± ---	± .0015	3 PLACES	± 0.038	± .005	2 PLACES	± 0.13	± .010	1 PLACE	± 0.3	± ---	DIMENSION STYLE MM/IN	TITLE	TERMINAL, SOLDER, W CAT.# 142	
			mm	INCH																	
	4 PLACES	± ---	± .0015																		
3 PLACES	± 0.038	± .005																			
2 PLACES	± 0.13	± .010																			
1 PLACE	± 0.3	± ---																			
ANGULAR ±1/2° DRAFT WHERE APPLICABLE MUST REMAIN WITHIN DIMENSIONS	DRAWN BY: R.STONE DATE: 08-19-03 CHECKED BY: RK DATE: 2-5-04 APPROVED BY: G.ROBERT DATE: 2-26-04	MATERIAL NO. 380020157 DOCUMENT NO. SD-38002-004 SHEET NO. 1 OF 1	MOLEX INCORPORATED																		
THIS DRAWING CONTAINS INFORMATION THAT IS PROPRIETARY TO MOLEX INCORPORATED AND SHOULD NOT BE USED WITHOUT WRITTEN PERMISSION																					

tb\_frame\_B  
rev. B1 2000/08/01

8 7 6 5 4 3 2 1