

Disconnect Terminals

Slide link disconnect terminals offer a superior solution for simple current transformer circuits and measurement transformer test sets using SAKT 1/LT lateral disconnect terminals, or SAKT 1/DU feed through terminals and SAKT 1/QT cross disconnect terminals.

Current transformers must always have a closed secondary circuit, even when changing measuring equipment (see schematic below).

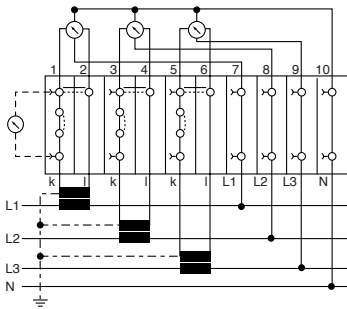

Stationary Jumpers

QL jumpers serve as fixed cross-connections for the Disconnect Terminals. The QL jumpers require the use of a fixing screw (BS M) and a connection sleeve (VH) when attaching the jumper to the current bar. The WQV jumpers are provided with a retained jumper screw.

Sliding Jumpers

QS and QVS jumpers are sliding jumpers. These jumpers are used to temporarily connect or disconnect adjacent terminal blocks. When the jumper screws are loose, the jumper can move to either open or close the cross connection between blocks. Tightening the jumper screws holds the jumper in either the open (disconnected) or closed (shorted) position.

QB jumpers work in a similar manner except that the jumpers remain fixed. An internal sliding connection link connected to the current bar either opens or closes the connection based on whether the link is in contact with the jumper or not.

SSP disconnect locks snap into the terminal block. These locks must be removed to change the position of the sliding link connection.

SAKT 1/LT

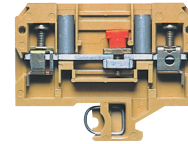

Slide Link

SAKT 2/LT

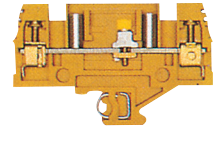

Slide Link

Terminal Block Selection Data

Available Options	Version	SAKT 1/LT	SAKT 2/LT
PA			
2 StB test points PA		0105660000	
Back wall closed KrG		0269120000	0105420000
Back wall open KrG			0445420000
4 StB 14 test points ø4.0 KrG 60 V**			0437720000
1 StB 8.5 test point ø2.0 KrG			0106020000
1 StB 8.5 test point ø2.3 KrG			
2 StB 14 test points ø4 KrG		0437920000	0105620000
2 StB 14 test points ø2.3 KrG			0330620000
			0105920000

Dimensions

Width / Length / Height mm (in.)	for TS 32	SAKT 1/LT	SAKT 2/LT
	↶	8/65/52.5 (.31/2.56/2.07)	8/82/52.5 (.31/3.23/2.07)
	↷	8/65/48.5 (.31/2.56/1.91)	8/82/48.5 (.31/3.23/1.91)
Insulation stripping length	mm (in.)	12 (.47)	12 (.47)

Technical Data

Rated voltage / rated current / wire size	UL	SAKT 1/LT	SAKT 2/LT
		300 V / 25 A / #22...8 AWG*	300 V / 25 A / #22...8 AWG*
	CSA	300 V / 25 A / #26...8 AWG	300 V / 25 A / #26...8 AWG
	VDE	380 VAC / 27 A / 6 mm²	380 VAC / 27 A / 6 mm²
Torque	Nm (lb. in.)	1.7 (16)	1.7 (16)
Clamping screw	M	3.5	3.5

Selected Accessory Data†

End Plate (thickness mm)	Type	Part No.	Type	Part No.	
PA	AP (1.5)	0146760000	AP (1.5)	0146760000	
KrG	AP (3.0)	0146720000	AP (1.5)	0329120000	
Partition (thickness mm)	PA	TW (1.5)	0242960000	TW (1.5)	0242960000
KrG	TW (3.0)	0242920000	TW (2.5)	0351820000	
HP	TW (0.5)	0474700000	TW (0.5)	0474700000	

Small Partition

TSch 2	0353660000	TSch 2	0353660000
--------	------------	--------	------------

Jumpers

QL fixed	QL 2	0194300000	QL 2	0194300000
QVS sliding	QL 3	0194400000	QL 3	0194400000
Connection sleeve	QL 4	0194500000	QL 4	0194500000
Fixing screw	QL 10	0338300000	QL 10	0338300000
	VH 12	0249000000	VH 12	0249000000
	BS M 3 x 20 Cu	0377100000	BS M 3 x 20 Cu	0377100000
	QS 2	0270960000	QS 2	0270960000
	QVS 2	0307300000	QVS 2	0307300000
	QVS 3	0329300000	QVS 3	0329300000
	QVS 4	0307400000	QVS 4	0307400000
	VH 19	0318000000	VH 19	0318000000
	BS 25 bare	0334700000	BS 25 bare	0334700000

Switchable Jumper Links

QB 2	0205700000	QB 2	0205700000
QB 3	0205800000	QB 3	0205800000
QB 4	0205900000	QB 4	0205900000
QB 10	0343800000	QB 10	0343800000

Test Plugs

PS 4	0299600000	PS 4	0299600000
------	------------	------	------------

Disconnect Lock

SSP 3	0531760000	SSP 3	0531760000
-------	------------	-------	------------

Marking Tags

	Print	SAKT 1/LT	SAKT 2/LT
Note: Part numbers are shown for a single card of pre-printed tags numbered 1-50.	Consecutive horizontal	DEK 5/6	0468660001
	Consecutive vertical	DEK 5/6	0468760001

†See Accessories section for additional information.
*For TS 35 #22...8 AWG
**With AP 380 V