

PS-5

Order No.: 3030983

<http://eshop.phoenixcontact.de/phoenix/treeViewClick.do?UID=3030983>

Test adapter, Color: red

Commercial data	
EAN	4017918818920
Pack	10 pcs.
Customs tariff	85369010
Weight/Piece	0.0033 KG
Catalog page information	Page 334 (CL-2009)

Product notes

WEEE/RoHS-compliant since:
01/01/2003

<http://www.download.phoenixcontact.com>
Please note that the data given here has been taken from the online catalog. For comprehensive information and data, please refer to the user documentation. The General Terms and Conditions of Use apply to Internet downloads.

Diagrams/Drawings

Dimensioned drawing

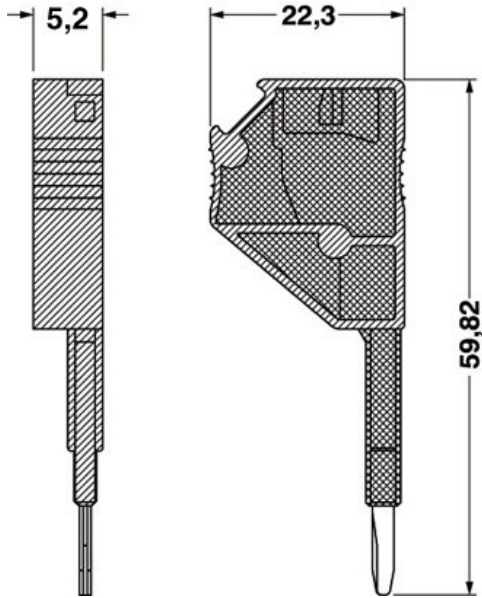

Address

PHOENIX CONTACT Inc., USA
586 Fulling Mill Road
Middletown, PA 17057, USA
Phone (800) 888-7388
Fax (717) 944-1625
<http://www.phoenixcon.com>



© 2010 Phoenix Contact
Technical modifications reserved;