

OEM ZIF DIP Sockets

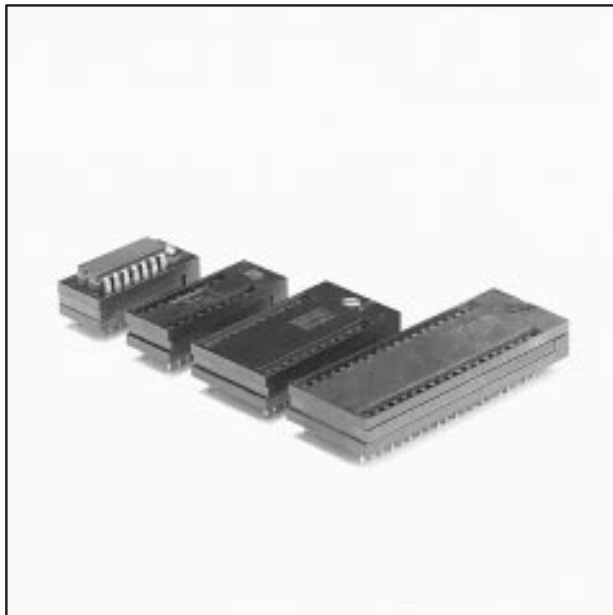

- BeCu contacts assure continuity with very short path to P.C. trace
- Contact design prevents solder bridging and wicking
- Zero insertion/extraction force achieved with simple cam rotation using a screwdriver
- For use where package field replacement or re-programming is required for DIP's
- Socket contact point of .110" (2.79 mm) below top surface of socket
- Pin counts available from 14 through 64 leads on .100" (2.54 mm) centers

Date Issued: January 12, 2004

TS-0360-14
Sheet 1 of 2

9.

Physical

Insulation

Material: Glass Filled Polyetherimide (PEI)
Flammability: UL 94V-0
Color: Black
Marking: Raised Letters: Part Identification

Contact

Material: Beryllium Copper
Plating
Underplate: 75 μ " [1.91 μ m] Copper – MIL-C-14550
Wiping Area & Solder Tails: 250 μ " [6.35 μ m] Tin – MIL-T -10727A
Optional Plating
Underplate: 50 μ " [1.27 μ m] Nickel
Wiping Area & Solder Tails: Gold Flash

Cam

Material: Zinc

Electrical

Current Rating: 1 A
Insulation Resistance: $> 1 \times 10^{12} \Omega$ at 500 Vdc
Withstanding Voltage: 1000 Vrms at Sea Level

Mechanical

Durability: 100 actuations
Normal Force: 150 grams average per contact

Environmental

Temperature Rating Operating: - 55 °C to +105°C

UL File No.: E68080

3M Electronic Solutions Division

6801 River Place Blvd.
Austin, TX 78726-9000

For technical, sales or ordering information call **800-225-5373**
or visit our website: <http://www.3M.com/esd>

OEM ZIF DIP Sockets

Lead Count	Dimensions				
	A	B	C	D	E
16	1.10 [28.0]	.49 [12.5]	.700 [17.78]	.300 [7.62]	.316 [8.02]
28	1.70 [43.2]	.80 [20.2]	1.300 [33.02]	.600 [15.24]	.316 [8.02]
32	1.90 [48.3]	.80 [20.2]	1.500 [38.1]	.600 [15.24]	.316 [8.02]

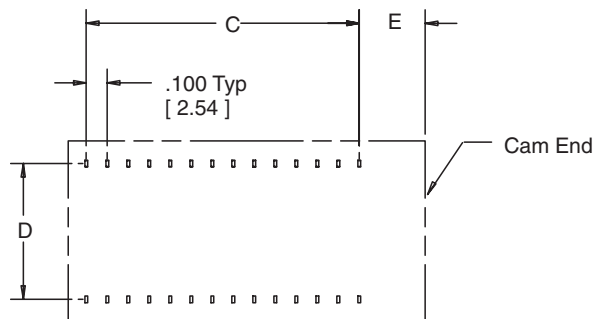
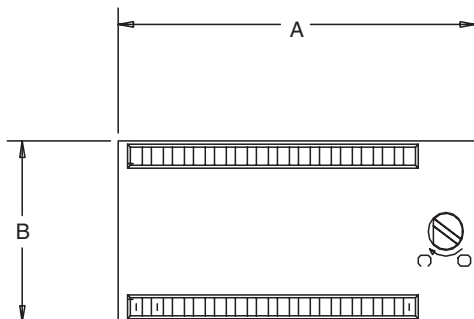

P.C. Board Pattern

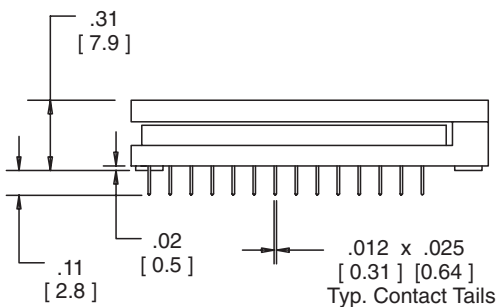

Dimension	Tolerance	
	inch (mm)	inch (mm)
Dimension	.00 (.0)	.000 (.00)
Tolerance	± .010 (± .25)	± .005 (± .13)

Notes:

1. When soldering to a P.C. Board the contacts must be in the **open position**. Do not crimp leads for mounting during soldering.
2. The cam mechanism in these sockets has been designed to operate with a torque level of 2 in-lbs max. Exceeding this torque level could cause damage to the socket.

Ordering Information

Lead Count	Part Number	Distance Between Rows
16	216-6278-00-3303	.300 [7.62]
28	228-1296-00-3303	.600 [15.24]
32	232-1297-00-3303	.600 [15.24]