

- RECEPTACLE ACCEPTS A .008-.014 THICK I.C. LEAD.
  - TUBE LOADED FOR AUTOMATIC INSERTION.
- △ TWO .00030 MIN THK. GOLD STRIPES IN CONTACT AREA WITH TIN-LEAD
  - △ TWO .00030 MIN THK. GOLD STRIPES IN CONTACT AREA WITH TIN-LEAD
  - △ TWO .00015 MIN THK. GOLD STRIPES IN CONTACT AREA WITH TIN-LEAD (93/7) ON CONTACT LEGS, BALANCE OF CONTACT NICKEL PLATED.
  - △ MAXIMUM DIMENSION FOR I.C. SEATING PLANE.

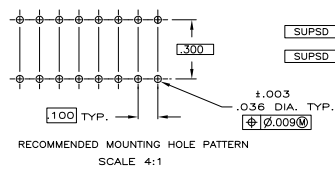
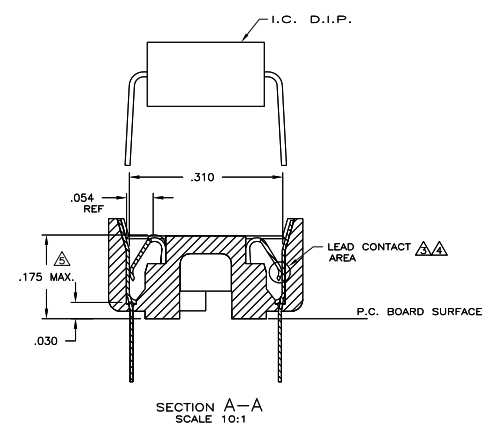
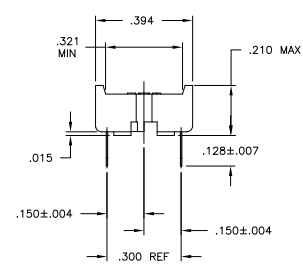
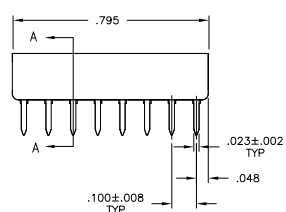
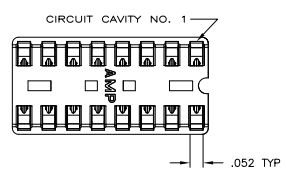

SUPSD BY 390261-4	TINNED	PRODS. 0.008 THK	GLASS-FILLED THERMOPLASTIC, 94V-0, BLACK	2-640358-4
SUPSD BY 390261-4	TINNED	PRODS. 0.008 THK	GLASS-FILLED THERMOPLASTIC, 94V-0, BLACK	2-640358-3
SUPSD BY 390261-4	TINNED	RE.CU. 0.008 THK	GLASS-FILLED THERMOPLASTIC, 94V-0, BLACK	2-640358-2
SUPSD BY 390261-4	TINNED	RE.CU. 0.008 THK	GLASS-FILLED THERMOPLASTIC, 94V-0, BLACK	2-640358-1

CONTACT FINISH		CONTACT MAT'L	HOUSING MATERIAL		PART NO.
THIS DRAWING IS A CONTROLLED DOCUMENT.					
REV	DATE	DESCRIPTION	BY	CHK	APP
1	108-1066	REVISED PER EDD-11-004917	11MMR11	RK	HMR
2	114-1049	REVISED PER EDD-11-004917	11MMR11	RK	HMR
3	100779	REVISED PER EDD-11-004917	11MMR11	RK	HMR